

**Functional Servicing and
Preliminary Stormwater
Management Report
Bay Moorings Marina
Town of Penetanguishene**

**February 2019
WMI File # 17-392**

Prepared by

**WMI & Associates Limited
119 Collier Street, Barrie Ontario L4M 1H5**



Table of Contents

1.0	Introduction	1
1.1	General	1
1.2	Background	1
1.3	Source Water Protection	2
2.0	Water Servicing	2
2.1	Proposed Servicing, Background & Existing Studies	2
3.0	Sanitary Servicing	3
4.0	Road Works and Site Grading	4
5.0	Stormwater Management	6
5.1	Pre-Development Drainage	6
5.2	Soil Conditions	6
5.3	Stormwater Management Design Criteria.....	7
5.4	Post-Development Drainage	8
5.5	Internal Post-Development Drainage and Lot Grading	8
6.0	Hydrologic Analysis	8
6.1	Pre-Development Condition Results	8
6.2	Post-Development Condition Results.....	9
7.0	Stormwater Quality Control	9
7.1	Total Suspended Solids Removal Initiatives.....	9
7.2	Total Phosphorus Removal Initiatives	11
7.3	Water Balance	11
8.0	Sediment and Erosion Controls	12
9.0	Utilities.....	12
10.0	Traffic Impact Assessment	13
10.1	Traffic Volume Impacts	13
10.1.1.	<i>Existing and Proposed Development Traffic.....</i>	<i>13</i>
10.2	Sight-Distance Analysis	14
11.0	Summary and Conclusions.....	14

Appendices

Appendix A – Figures and Concept Plan

Appendix B – Calculations

Appendix C – Geotechnical Investigation / Hydrogeological Study

Appendix D – Correspondence

Appendix E – Traffic Impact Assessment Calculations

Appendix F – Record Drawings, Town of Penetanguishene

1.0 Introduction

1.1 General

WMI & Associates Limited has been retained by Bay Moorings Marina to prepare a Functional Servicing and Preliminary Stormwater Management Report in support of a draft plan of subdivision located at 160-200 Fox Street, in the Town of Penetanguishene, Ontario. This report is based on our pre-consultation discussions with Town of Penetanguishene Staff. The engineering analysis and design outlined in this report conforms with the following:

- Town of Penetanguishene Land Development Engineering Policy (Revision No. 1, April, 2009).
- Ministry of Environment (MOE) Stormwater Management Practices Planning and Design Manual (2003).
- Ministry of Natural Resources (MNR) Natural Hazards Training Manual: Provincial Policy Statement, Public Health and Safety Policies 3. (1997).
- MOE and MNR Best Management Practices Manual (1991).
- Hydrogeological Assessment Submissions Conservation Authority Guidelines for Development Applications (June, 2013).
- Severn Sound Environmental Association (SSEA), Severn Sound Remedial Action Plan, Urban Stormwater Management Strategy (December, 1998).
- South Georgian Bay Lake Simcoe Source Protection Region, Approved South Georgian Bay Lake Simcoe Source Protection Plan (January 26, 2015, Amended February 15, 2018).
- Low Impact Development Stormwater Management Planning And Design Guide Version 1.0, CVCA & TRCA (2010).
- Ontario Building Code (Sept. 14, 2012 and current addendums).

1.2 Background

The subject site is approximately 6.40 hectares in size and is located on the eastern shore of the Penetanguishene Harbour waterfront, at 160-200 Fox Street. The general location of the property is illustrated on **FIG 1** in **Appendix A** (Site Location Plan) and will be referred to as the “site” within the context of this Report.

The site is legally described as Lots 115, 116, 119 and Part of Oxford Street and all of Block C, and Part of Cambridge Street, and Part of Lots 114 & 118 all west of Fox Street and Water Lot “B” and Part of Water Lot “A”, Registered Plan 70, Town of Penetanguishene, County of Simcoe.

The site currently consists of a marina complete with office buildings, storage buildings, boat slips, swimming pool, tennis court, and a small residential lot. The majority of the remaining site area consists of asphalt and gravel areas used for boat trailer storage and parking.

It is proposed to reduce this marina substantially and move operations to the southern portion of the site, while the remaining northern portion of the site will be subdivided into 22 townhouse units, 36 condo units, and 28 single detached residential lots on which residential dwellings (approximately 2300sq.ft. each) will be constructed. Refer to **FIG3** in **Appendix A** as well as the Development Concept Plan (dated January 25, 2019) in **Appendix A**.

The site will be serviced by a proposed watermain and sanitary sewer, both to be connected to the existing services within the Fox Street right-of-way. The stormwater management controls designed for this development will use an integrated treatment train approach to provide stormwater quality control on-site.

1.3 Source Water Protection

From a source water protection perspective, and based on a review of the South Georgian Bay Lake Simcoe Source Protection Region (Approved South Georgian Bay Lake Simcoe Source Protection Plan, January 26, 2015 - amended February 15, 2018 - and MOECC's Source Protection Atlas), a small south eastern corner of the subject site is located within a Wellhead Protection Area, and a Highly Vulnerable Aquifer Area.

This portion of the site contains part of the proposed Marina lands and associated asphalt area. The asphalt area will be graded towards Dry Detention Basin #1 located outside of the source water protection area. Due to the nature of the grading, stormwater will not enter the source water protection area. Therefore, the development and the associated engineering design is not subject to further design requirements related to source water protection (i.e. there are no water quantity threats and as a result a Section 59 Notice is not required). However, we note that water balance is still required in accordance with the Conservation Authority's hydrogeological guidelines (refer to **Section 7.3, Water Balance**).

2.0 Water Servicing

2.1 Proposed Servicing, Background & Existing Studies

Based on the calculated fire flows for each of the governing buildings within the commercial and residential areas of the development and the Hydrant Flow Curve Detailed Report provided by the Town, the available pressure and flow at the existing 200mm \varnothing watermain located within the Fox Street right-of-way, a 200mm \varnothing internal looped watermain is proposed to provide the on-site domestic and fire services (see drawing **FIG 4** in **Appendix A**).

The proposed water distribution system will be connected to the existing 200mm \varnothing watermain located within the Fox Street right-of-way. The connection is proposed to be located on the east side of the Fox Street right-of-way on the north side of Unit #232 at the north end of the site (see **FIG 4** in **Appendix A**).

The proposed system will include a meter chamber complete with a compound water meter, backflow prevention, and an external by-pass.

Hydrant flow data has been provided for the two (2) nearest hydrants within the Fox Street right-of-way. The Hydrant Flow Data Curve 36 was conservatively used to determine the available pressure from the existing watermain. For Fire Flow calculations, conservative interpolations were made to determine the available pressure at the connection point depending on the governing fire flows (See **Appendix B**). Considering this and the OBC's minimum allowable distance to a fire hydrant for fire supply water, on-site fire hydrants are proposed for both the commercial and residential areas of the subject development at a maximum spacing of 150m, as per municipal standard.

Based on municipal design standards, the proposed commercial and residential buildings will be serviced via 50mm \varnothing and 25mm \varnothing domestic water service connections respectively. The watermain and fire flow design calculations are included in **Appendix B**.

Considering the presence of an existing 200mm \varnothing watermain along the site frontage (Fox Street), no domestic or fire supply issues are anticipated in regards to servicing the proposed mixed commercial and residential development. During the detailed design stage, a fire flow test will be completed in accordance with Town Standards in order to establish the boundary conditions for fire flow requirements. Demand water flows will be provided by the project mechanical engineer at the detailed design stage in order to determine pipe sizing.

3.0 Sanitary Servicing

There is an existing municipal sanitary sewer system along the frontage of the site. The sewer size varies (400mm \varnothing and 500mm \varnothing) and is located within the west site boulevard of Fox Street. An internal private 200mm \varnothing sanitary sewer system is proposed to service all 86 residential units and two commercial buildings proposed within the site.

The proposed sanitary sewer for the site will be connected to the existing 500mm \varnothing sanitary sewer within the Fox Street right-of-way by installing a sanitary doghouse manhole in the existing sewer located at the proposed southern entrance to the site. The proposed 200mm \varnothing sanitary sewer will service each of the proposed residential and commercial buildings as illustrated on the Conceptual Servicing Plan (**FIG 4**) provided in **Appendix A**. The sanitary servicing for the proposed development has been designed in accordance with the Town of Penetanguishene Land Development Engineering Policy. Estimated sanitary sewage design flows have been calculated using the sewage flow design criteria set-out in the Ontario Building Code (2012), as well as the criteria of the MOE's Design Guidelines for Sewage Works (2008).

The sewage flows for the proposed development were determined via the use of the Ministry of the Environment's (MOE's) standard calculations and the Ontario Building

Code's (OBC's) total daily sewage flow data. To determine the total daily sewage flow rate for each of the buildings proposed, Tables 8.2.1.3.A and 8.2.1.3.B. of the 2012 Ontario Building Code (OBC) were referenced. Using Tables 8.2.1.3.A and 8.2.1.3.B., the total daily sewage flow rate for the total commercial and residential portions of the development were determined to be 5250 L/day and 450,144 L/day respectively. A peaking factor of 1.5 for commercial development and just over 4 for the residential development (based on typical Harmon formula) were used to size the site's sanitary sewer conveyance system.

Due to grading constraints in the northern portion of the site, a pump-station (Pump Station #1 – PS1) will be used in conjunction with a 50mm \varnothing forcemain to convey flows to proposed Sanitary Manhole H (MHH), where positive grade towards the proposed sanitary sewer outlet is achieved (see **FIG 4** in **Appendix A**). A JB Submersible Station with 5HP Submersible Grinder Pumps has been recommended by Brooks Application Engineering (see attached specifications in **Appendix D**). The design inverts have been incorporated into the proposed **Sanitary Sewer Design Sheet** included in **Appendix B**.

Due to a lack of detail available at this stage with respect to the proposed commercial building uses/tenants, some assumptions were made in regard to the proposed building uses and their contributing sewage flows to the Fox Street right-of-way which will be refined during the detailed design stage. Refer to the **Sanitary Sewer Design Sheet** in **Appendix B** for the sanitary service design calculations.

It is noted that the Geotechnical Investigation prepared by MTE Consultants Inc. (dated September 4, 2018) recommends the installation of clay or concrete cut-off collars 1.0m long to prevent the movement of groundwater along pipe bedding. The requirement for installation of the cut-off collars will be assessed at the time of construction in coordination with the geotechnical engineer.

4.0 Road Works and Site Grading

The preliminary grading of the site is shown on the Site Grading Concept Plan, **FIG 5** included in **Appendix A**. The proposed grading will meet the requirements of the site layout and stormwater management strategy. In order to achieve these goals, the following design criteria were used;

- Grading of roadway, parking and landscaped areas to be completed according to the Town of Penetanguishene engineering standards where possible;
- Minimize earthworks operations on-site (i.e. minimize cut/fill);
- Provide overland conveyance of stormwater to the proposed stormwater management facilities;
- Minimize the need for steep slopes where practical.

Based on the Geotechnical Investigation prepared by MTE Consultants Inc. (dated September 4, 2018), the proposed design for the private roads, marina parking lot and visitor parking is:

- 90mm Hot Mix Asphalt
- 150mm Granular A
- 300mm Granular B
- Complete with 270R Non-Woven Geotextile in conjunction with TX140 Geogrid

It is recommended that the geotechnical engineer review the final engineering drawings during detailed design to confirm pavement structure, pipe bedding, slope stability, etc.

The site will consist of rear-to-front and split lot drainage with the front yards being directed to the proposed roadway while the rear yards will be directed to grass swales. Stormwater runoff will ultimately be directed into the proposed stormwater management dry detention basins, located in the south, central and northern portions of the site respectively. Grass swales will convey flows from the rear yards along the Fox Street right-of-way to lot line swales, ultimately directing flows to the proposed roadway.

Design grades on the site range from 0.5 to 6.0% with specific areas consisting of up to 3:1 (H:V) side slopes in order to match existing grades at property line.

Based on the recommendations in the Geotechnical Investigation prepared by MTE Consultants Inc. (dated September 4, 2018) the proposed residential buildings will be constructed without basements and each building will be constructed with a structural slab-on-grade main floor and footings supported by helical piles.

It is noted that MTE Consultants Inc. are preparing a Phase Two Environmental Site Assessment (ESA). The ESA and supporting reports will be utilized by MTE to prepare a Record of Site Condition for various parcels of the site. The preliminary recommendations include the remediation of existing soils in specific areas and the workplan includes remediation of approximately 10,000–12,000m³. Based on our discussions with MTE the soils can be re-located within site depending on the land use of the receiving area. In the event that site grading will not permit relocation of these soils the material will be exported to a licensed disposal site. Ultimately, the soil remediation plan will be finalized by the environmental engineer and coordinated during detailed design of the site servicing and grading. Refer to the letter from MTE Consultants Inc. (dated October 11th, 2018), included in **Appendix D**.

5.0 Stormwater Management

5.1 Pre-Development Drainage

The pre-development condition of the site has been confirmed through a combination of topographic survey elevations, Simcoe County Interactive Mapping (GIS topographic contour) and a site visit.

All pre-development runoff from the site takes place in the form of overland sheet flow, generally from east to west. There are no external drainage areas due to the nature of the grading both within the site and along its perimeter. The governing drainage pattern within the site is uncontrolled overland sheet flow from east to west, with all stormwater flowing directly into Penetanguishene Harbour.

Land cover within the site varies from north to south. For this reason, the site has been divided into two pre-development catchments: North (4.83ha), and South (1.57ha). See **FIG 2, Appendix A**. The land cover in the northern portion of the site is mainly impervious with some lawn and tree cover, while the southern portion of the site consists of lawn, gravel, and tree cover. Throughout the entire site all runoff discharges uncontrolled to the harbour.

The elevation relief across the site is approximately 5m with the highest elevations located along the eastern property limit of the site (Fox Street), and the lowest elevations located along the western limit (waterfront).

Along the site's southern border is a municipal facility, and along the northern border is Dutchman's Cove Marina. The site's eastern border runs along the Fox Street right-of-way, where a roadside ditch flowing north to south captures and conveys all runoff from the east. As a result, there is no external drainage contributing runoff to the site.

5.2 Soil Conditions

According to the Soils Map of Simcoe County, Ontario, Soil Survey (prepared by the Department of Soils, Ontario Agricultural College, Guelph and the Department of Agriculture), the subject site consists primarily of Tioga Loamy Sand and Alliston Sandy Loam. These soil types are within Hydrologic Soil Groups 'A' and 'AB' respectively. Tioga Loamy Sand is considered to be a good draining soil, whereas the Alliston Sandy Loam is considered to be an imperfect draining soil.

The above-mentioned soil types were confirmed in the Geotechnical Investigation Report prepared by MTE Consultants Inc. (May 8, 2018). Twenty (20) boreholes were dug on-site and revealed varying layers of "asphaltic concrete and/or fill overlying native sand, silt, and clay deposits" throughout the site. The report concludes that, "Due to the high groundwater table, at approximately elevation 176.89 to 179.34m, and the large amount of fill materials at the site, at-source infiltration of stormwater runoff is not geotechnically feasible for the development." This was taken into consideration in developing a feasible approach to stormwater quality control and water balance.

A Hydrogeological Study and Water Balance Analysis was conducted by Ian D. Wilson Associates (Revised Feb. 13, 2019) which addressed the findings in the Geotechnical

Investigation. The Hydrogeological report concluded that, “the predominant native soils (i.e. silty fine sand) will exhibit a percolation rate (T-time) in the range of 10 to 12 min/cm...LID measures with a total site footprint of at least 230m² are required.” This minimum footprint was exceeded in the proposed stormwater management design (see **Section 7.3**).

Runoff coefficients associated with the site were determined by calculating weighted values based on corresponding land uses and soil type. The Hydrologic Soil Group was determined in accordance with the Ontario Ministry of Transportation (MTO) Soil Classification System.

Refer to both the **Geotechnical Investigation**, and **Hydrogeological Study and Water Balance Analysis** included in **Appendix C**.

5.3 Stormwater Management Design Criteria

The SWM design for the site incorporates the policies and criteria of a number of agencies, including the Ministry of the Environment, Conservation and Parks (“MECP”) and the Town of Penetanguishene.

The requirement to provide both water balance and stormwater quality control for the site necessitated additional design considerations such as the use of low impact development (“LID”) techniques. The proposed LID components are based on the Low Impact Development Stormwater Management Planning & Design Guide (LID) prepared by the Credit Valley Conservation (CVC) and the Toronto and Region Conservation Authority (TRCA), Version 1.0, dated 2010. The stormwater design criteria for the proposed development are summarized in the following:

- Stormwater quality controls will be provided based on the guidelines described in the Ministry of the Environment, Stormwater Management Planning and Design Manual dated March 2003 and the Low Impact Development Stormwater Management Planning & Design Guide (LID) prepared by the Credit Valley Conservation (CVC) and the Toronto and Region Conservation Authority (TRCA), Version 1.0, dated 2010. In accordance with the MECP and LID Guidelines noted above, the stormwater management design utilized for the site will provide water quality control at an Enhanced Level of Protection (minimum of 80% Total Suspended Solids removal efficiency).
- Site layout and stormwater management design are based on the guidelines described in the Source Protection Plan.
- Since stormwater will directly discharge to Penetanguishene Harbour after passing through the proposed LIDs for quality control, no stormwater quantity control is provided.
- Stormwater quality controls will be implemented using a treatment train approach. This approach is premised on stormwater being pre-treated by oil-grit-separators before being directed to dry detention basins which are considered to perform similarly to Low Impact Development (LID) Enhanced Grass Swales. Runoff will be filtrated as well as infiltrated into the in-situ soils, while the proposed grass cover/landscaping will provide nutrient uptake and evapotranspiration.

- Erosion and Sediment Control measures will be implemented prior to and during the construction of the development and maintained until the site is stabilized.

5.4 Post-Development Drainage

In regard to the post-development peak flow rates and water quality, the post-development drainage patterns are generally consistent with that of pre-development conditions. Due to the impervious nature of the existing site, the proposed development will actually decrease the amount of total impervious area in the post-development condition. As mentioned previously, quantity controls are not required for this site (see **Section 6.2** for details).

An integrated treatment train approach consisting of LID Best Management Practices (“BMPs”) has been proposed to fully address stormwater quality control. Based on the revised grading design in the post-development condition, the site will be divided into five (5) separate post-development catchments, referred to as A1 (0.11ha), A2 (2.22ha), A3 (1.17ha), A4 (2.72ha), A5 (0.23ha). Each catchment is delineated to show where flow is directed as shown on **FIG 3** in **Appendix A**. Refer to **Section 7.0** for details on stormwater quality control.

5.5 Internal Post-Development Drainage and Lot Grading

Individual lots will be graded primarily by split-lot drainage, with the front yards being sloped towards the proposed streets, and the backyards being directed towards the rear of the lots.

Because the site slopes towards Penetanguishene Harbour, the rear yards on the waterfront lots will be graded such that clean runoff flows directly into the harbour via overland sheet flow. Additionally, the rear yards along the Fox Street right-of-way will be graded such that clean runoff flows into the existing grass swale. These flows will be minor and only contact roofs and rear yards (free of contamination). The grass on the rear yards will act as grass filter strips providing filtration, nutrient uptake, evapotranspiration as well as some infiltration into the native soils.

The majority of all impervious area on site will be graded such that runoff will be directed through oil-grit-separators (OGS) for pre-treatment and then into the proposed dry detention basins for quality control before discharging into Penetanguishene Harbour.

Refer to **FIG 3** in **Appendix A** for the **Post-Development Drainage Plan**.

6.0 Hydrologic Analysis

6.1 Pre-Development Condition Results

Using the site drainage areas as illustrated on **FIG 2**, **FIG 3** (see **Appendix A**) and the Rational Method, the total flows were determined for the 2, 5, 10, 25, 50 & 100-year

for both the pre-development and post-development design storm events. The pre-development flows are summarized in **Table 1** below. The stormwater management design calculations including the Rational Method peak flow values can be found in **Appendix B**.

Table 1: Pre-Development Peak Flows

Catchment	Area (ha)	Pre-Development Peak Flows					
		2 yr. m ³ /s	5 yr. m ³ /s	10 yr. m ³ /s	25 yr. m ³ /s	50 yr. m ³ /s	100 yr. m ³ /s
PRE NORTH	4.63	0.551	0.732	0.850	1.097	1.329	1.523
PRE SOUTH	1.57	0.047	0.062	0.072	0.093	0.113	0.129
TOTAL	6.40	0.598	0.794	0.922	1.190	1.442	1.652

6.2 Post-Development Condition Results

The post-development peak flows are summarized in **Table 2** below.

Table 2: Post-Development Uncontrolled Peak Flows

Catchment	Area (ha)	Pre-Development Peak Flows					
		2 yr. m ³ /s	5 yr. m ³ /s	10 yr. m ³ /s	25 yr. m ³ /s	50 yr. m ³ /s	100 yr. m ³ /s
POST A1	0.11	0.005	0.007	0.008	0.010	0.012	0.014
POST A2	2.22	0.191	0.254	0.295	0.381	0.461	0.528
POST A3	1.17	0.026	0.034	0.040	0.051	0.062	0.071
POST A4	2.72	0.273	0.362	0.421	0.542	0.658	0.753
POST A5	0.23	0.002	0.002	0.003	0.004	0.004	0.005
TOTAL	6.40	0.497	0.659	0.766	0.988	1.197	1.372

By comparing **Tables 1** and **2** for the site drainage area it is evident that due to the reduction in impervious area within the proposed development, the post-development peak flows are less than the pre-development flows. In addition, since stormwater will directly discharge to Penetanguishene Harbour after passing through the proposed LIDs for quality control, there is no need for quantity control in the proposed design.

7.0 Stormwater Quality Control

7.1 Total Suspended Solids Removal Initiatives

In determining the best approach to providing quality control for the proposed development, various factors were considered, including the following:

- Existing land characteristics and uses (soils, topography, treatment area, location, etc.).

- The nature of contamination of stormwater runoff in the post-development condition;
- The magnitude of change in impervious area from the pre-development condition;
- Local requirements and maintenance considerations with regard to quality control;
- Utilizing an 'integrated treatment train' approach to treat stormwater runoff;
- Ability to utilize landscaped areas and providing water balance and nutrient uptake benefits.

Based on the above noted factors, the application of reduced lot grading, lot line swales, grass filter strips and oil-grit separators in conjunction with dry detention basins (considered to act similarly to Low Impact Development (LID) enhanced grass swales), capable of filtration, infiltration, nutrient uptake and evapotranspiration benefits, has been chosen as the preferred means of providing a complete treatment train approach for the treatment of stormwater runoff generated on-site. This treatment train approach will effectively achieve an "Enhanced" Level of Protection (80% TSS removal efficiency).

As noted above, oil-grit separators are proposed to be located just upstream of each dry detention basin where the respective storm sewers converge, and will be used as a means of providing pre-treatment prior to runoff entering the proposed dry detention basins. Additionally, sediment traps via sumps within each proposed storm structure (catchbasins and manholes) upstream of the oil-grit separators will provide additional pre-treatment of stormwater runoff. Oil-grit separators provide a "Normal" Level of Protection of quality control (70% TSS removal efficiency), as defined in the MOECC's Stormwater Management Planning & Design Manual (2003). As part of the overall treatment train, additional quality control benefits will be provided as pre-treated stormwater is discharged from the oil-grit separators into the proposed dry detention basins.

Referencing the LID & MECP Guidelines, the site grading is such that the vast majority of the site's impervious area (rooftops, asphalt roads/parking areas and driveways) is directed to both the proposed oil-grit separators and dry detention basins. In areas where split-lot drainage causes stormwater runoff to flow directly into Penetanguishene Harbour, it is noted that not only is this runoff uncontaminated (rooftop/rear yard lawns), but the rear yard lawns will act as grass filter strips which filtrate, infiltrate and provide nutrient uptake and evapotranspiration benefits to stormwater runoff.

The sizing and design of the dry detention basins is in essence the same as large enhanced grass swales. Based upon guidance from the LID Manual, the basins will consist of large flat bottoms, 3:1 (H:V) side slopes, and the majority of their longitudinal slopes being set at 1.0% or less. The runoff will back-up and pool in the dry detention basins providing opportunity for filtration, nutrient uptake, evapotranspiration, and some infiltration prior to discharge. The dry detention basins will perform, at a minimum, with the same characteristics as enhanced grass swales.

Based on the information provided in the LID Guide, the median pollutant mass removal rates of Enhanced Grass Swales are considered to be 76% for total suspended solids, 55% for total phosphorus and 50% for total nitrogen based on available

performance studies. Since the oil-grit separators upstream of each basin will 70% TSS alone, and considering that the dry detention basins exhibit most (if not all) of the design recommendations for enhanced grass swales (76% TSS removal on remaining suspended solids after pre-treatment), it is reasonable to assume that 80% Total Suspended Solids (TSS) removal efficiency is considered to be achievable on-site via the use of the proposed treatment train approach.

Refer to **FIG 5** (Site Grading Plan) in **Appendix A** for the location and design parameters of the dry detention basins.

7.2 Total Phosphorus Removal Initiatives

Phosphorus removal initiatives are also proposed for the site. The various BMPs proposed for the development which will provide phosphorus loading reduction benefits include the grass filter strips (rear yards), lot line swales and dry detention basins located throughout the overall drainage system. These stormwater management features will retain pollutants and nutrients such as phosphorus during minor rainfall events as they have been designed to accept the vast majority of the site's runoff from impervious surfaces.

Based on the information provided in the LID Guide, the median pollutant mass removal rate for an enhanced grass swale is considered to be approximately 55% for total phosphorus. As discussed previously, considering the dry detention basins are in essence large enhanced grass swales, they will provide a minimum phosphorous reduction of 55%. In addition, the dry detention basins have been designed to detain stormwater runoff prior to discharging to the Harbour. This will provide opportunity for infiltration into the native soils.

7.3 Water Balance

A Hydrogeological Study and Water Balance Analysis was prepared by Ian D. Wilson Associates, Ltd. (Revised Feb. 13, 2019) and assumed that infiltration rates would need to be maintained to pre-development conditions (i.e. greenspace prior to the existing development). In order to maintain infiltration rates to pre-development conditions, while considering the imperfectly draining soils on-site, the proposed LIDs will be required to have a total base area of 230m² (minimum) to infiltrate the necessary volume of stormwater. This requirement has been exceeded in the proposed design. The total base area of the dry detention basins alone (excluding side slopes) yields 501 m². The base of each proposed dry detention basin will be kept a minimum of 0.5m above the estimated groundwater level.

Refer to **FIG 5** in **Appendix A** for the location and elevations of the proposed dry detention basins.

Refer to the Hydrogeological Evaluation prepared by Ian D. Wilson Associates, Ltd. (Revised Feb. 13, 2019) included in **Appendix C**.

8.0 Sediment and Erosion Controls

In accordance with the Town and SSEA policy, effective erosion and sediment control must be established prior to construction commencement and maintained until the site has been stabilized. Exposure of the soil during construction should be minimized to avoid erosion and sedimentation. The site's erosion potential may be mitigated through the use of sound erosion and sedimentation control measures. The following measures must be carried out prior to construction and maintained until disturbed areas have regained significant vegetative cover:

Topsoil Stripping: Topsoil stripping will be reduced as much as possible on-site. Where grading is necessary, the exposed soil will be stabilized by seeding immediately upon being set to grade. Should topsoil stockpiling be required, the stockpiles will be kept at manageable levels for grass/weed cutting purposes.

Silt Fence: Silt fence will be placed along the down slope of all excavated material and along the perimeter of the site to prevent sediment transport. Periodic inspections and repairs to the silt fence should be performed regularly, as well as after every rainfall event.
Mud Mat: Mud tracking from construction traffic must be controlled through the use of a mud-mat consisting of clear stone located at the site's construction entrances/ exits.

Vegetated Buffers: Existing grassland vegetation/wooded and lawn areas along the development limits are to be maintained wherever possible. These areas will provide a natural barrier to filter potentially sediment-laden overland flow before it is released from the site.

Conveyance Protection: Straw bale check dams will be placed within all swales immediately after being constructed and should be removed only after the area has been fully stabilized.

Finally, the Site Engineer will be responsible for completing routine inspections of the sediment and erosion control structures throughout the construction phase of the development, particularly after rainfall events. All damaged or clogged control devices or fencing must be repaired immediately.

9.0 Utilities

Existing gas, hydro and telecom infrastructure is present within the Fox Street right-of-way. In order to confirm that each of these services are available to service the proposed subdivision, the following utilities have been circulated a copy of the Draft Plan;

- Bell
- Rogers
- Hydro One
- Enbridge
- Canada Post

Based on the utilities that currently service the surrounding community, it is anticipated that there will be no issues with providing utility servicing for the site. Specific utility servicing requirements will be confirmed at the detailed design stage.

10.0 Traffic Impact Assessment

A scoped Traffic Impact Assessment has been conducted for the site to determine the projected traffic volume impacts on the existing road network, and assess the sight-distance geometry from the two proposed site access locations.

10.1 Traffic Volume Impacts

Traffic patterns from this development will be somewhat variable since the different uses will exhibit different patterns, however since the marina will inherently generate the majority of vehicular trips it will be the most impactful in terms of traffic generation onto Fox Street. In this regard, it can be said that traffic patterns from the proposed development as a whole will function similarly to the traffic currently being generated by the existing Bay Moorings Marina facility.

Due to this inherent similarity, the traffic volume impacts have been assessed by comparing the theoretical trips generated from the site relative to the trips generated from the existing 332-slip Bay Moorings Marina that currently operates on the site.

10.1.1. Existing and Proposed Development Traffic

Estimated trip generation rates were determined using the Institute of Transportation Engineers' (ITE) Trip Generation Manual, 10th Edition.

Although the residential portion of the development comprises a mix of attached and detached dwellings, for the purpose of this analysis the ITE statistical data for senior adult detached housing has been utilized as there is more statistical data available in the Manual for this form of development. As well, the trip generation rates are slightly more conservative.

Using the data from ITE land use #251, 'Senior Adult Housing- Detached' the average peak hourly trip generation rate relative to the number of dwelling units over a variety of peak time frames is approximately equal to 0.30 trip ends per unit. From this, the estimated peak hourly trips is estimated to be 26 for the 86 residential units.

Using the data provided under land use #420- Marina facilities, an approximate average number of peak hourly trips under a variety of peak time frames is 0.25 trips ends per berth (boat slip). Based on the site plan, which is to include a 200 slip marina, there is estimated to be 50 peak hourly trips from the new marina site. Therefore, the overall site is estimated to generate $26 + 50 = 76$ peak hour trips.

Using the same 0.25 trips per boat slip rate applied to the existing Bay Moorings Marina facility which comprises approximately 332 boat slips, the estimated peak hourly trips under the existing condition is 83.

Since there is a net reduction in the estimated peak hour trips from the existing (83 trips) to proposed (76 trips) condition, it is expected that the site can be accommodated by the existing road network with less impact as compared to the existing condition.

Furthermore, the distribution of trips (to the north and south on Fox Street) is expected to be similar to the existing condition, due to the inherent similarities between the existing and site as described previously.

10.2 Sight-Distance Analysis

Ontario's Ministry of Transportation (MTO) outlines specific sight-distance geometry criteria to ensure safe vehicular movement to and from intersecting roadways and to ensure that through traffic on the adjacent roadway will have adequate time and space for manoeuvrability and braking. Based on a design speed of 50km/hr, the minimum required sight-distance is approximately 130m, as referenced from MTO Geometric Design Standards for Ontario Highways Manual, Figure E3-6. A copy of this figure is contained in **Appendix D** for reference.

From a desktop review of existing site conditions and sight-lines from the vantage point of the proposed site accesses onto Fox Street, visibility is noted to be adequate, since there are no notable obstructions in road alignment between the proposed site access locations up to and including 130m meters away in either direction. Based on these observations, sight-distance from the four proposed site access locations is noted to be satisfactory.

11.0 Summary and Conclusions

This Functional Servicing and Preliminary Stormwater Management Report demonstrates that the site can be serviced in accordance with MECP and SSEA best management practices. Specifically, we note the following:

- The site can be serviced by installing a watermain that will be connected to the existing watermain within the Fox Street right-of-way.
- Fire protection can be provided by hydrants on the proposed watermain. Adequate flow has been confirmed by hydrant testing performed by the Town of Penetanguishene.
- The site can be serviced by a sanitary sewer system connected to the existing sanitary sewer within the Fox Street right-of-way.
- The proposed treatment train approach (including the oil-grit separators) will provide an 'Enhanced' Level of Protection, as defined in the MOE's Stormwater Management Planning & Design Manual.

- Water balance and total phosphorous reduction initiatives will be implemented in accordance with the South Georgian Bay Lake Simcoe Source Protection Plan requirements.
- There are no traffic volume impacts as a result of the development of the site. In addition, site distances from the proposed entrances are adequate.
- The use of silt fencing, existing vegetated buffers, straw bale check dams, and construction mud mats will ensure downstream stormwater quality is maintained during construction.
- The site is anticipated to be serviced by natural gas, hydro, telephone and cable TV services available on Fox Street.

Based on the above, please accept this Report in support of the Bay Moorings Marina planning level approvals.

Respectfully submitted,

WMI & Associates Limited



Benjamin Daniels, B. Eng.



Jeremy Lighthouse, P. Eng.

APPENDIX A

FIGURES

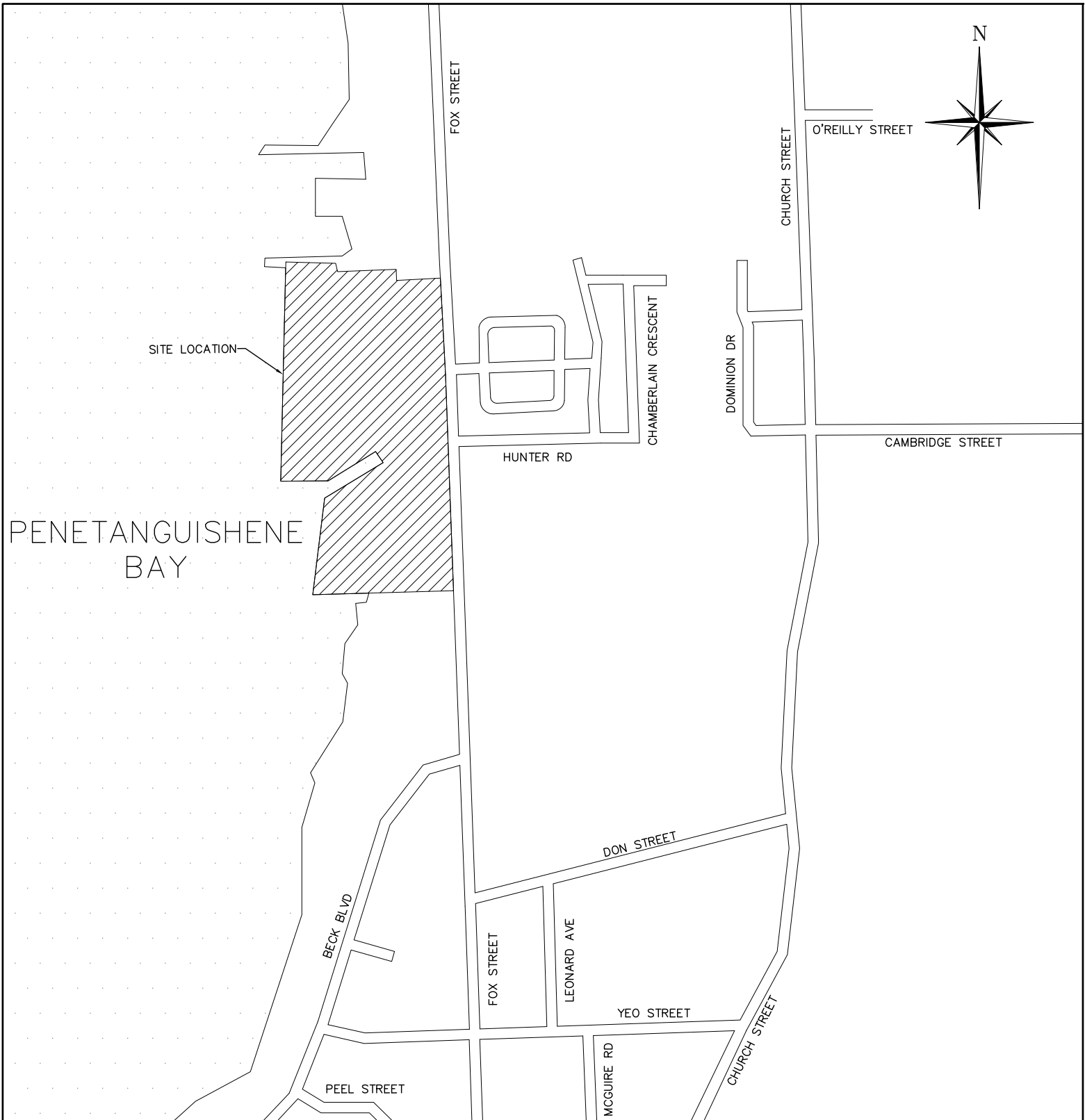

Drawing Title

SITE LOCATION PLAN

Project Title

BAY MOORINGS MARINA



WMI & Associates Limited
 119 Collier Street
 Barrie, Ontario
 L4M 1H5
 705-797-2027
 www.wmiengineering.ca

Drawn By
 BD

Checked By
 RDW

Figure No.

Scale
 N.T.S.

Project No.
 17-392

FIG1

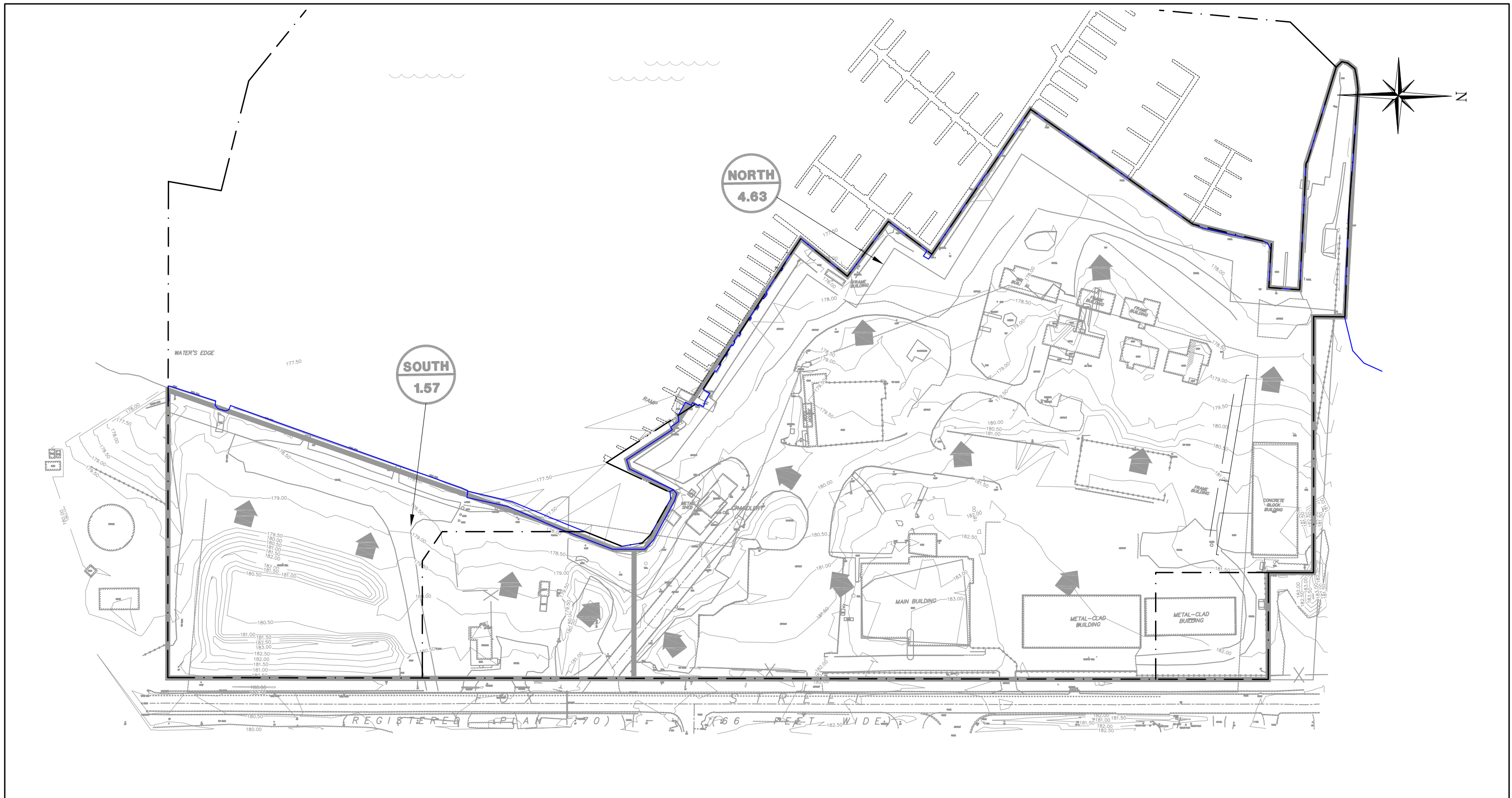

LEGEND:

- 0

CATCHMENT I.D.
- 0.00

DRAINAGE AREA (ha)
- CATCHMENT BOUNDARY
- RUNOFF FLOW DIRECTION

Drawing Title PRE-DEVELOPMENT DRAINAGE PLAN		<p>WMI & Associates Limited 119 Collier Street Barrie, Ontario L4M 1H5 705-797-2027 www.wmiengineering.ca</p>		
Project Title BAY MOORINGS MARINA				
Drawn By	BD	Checked By	RDW	FIG 2
Scale	1:1500	Project No.	17-392	

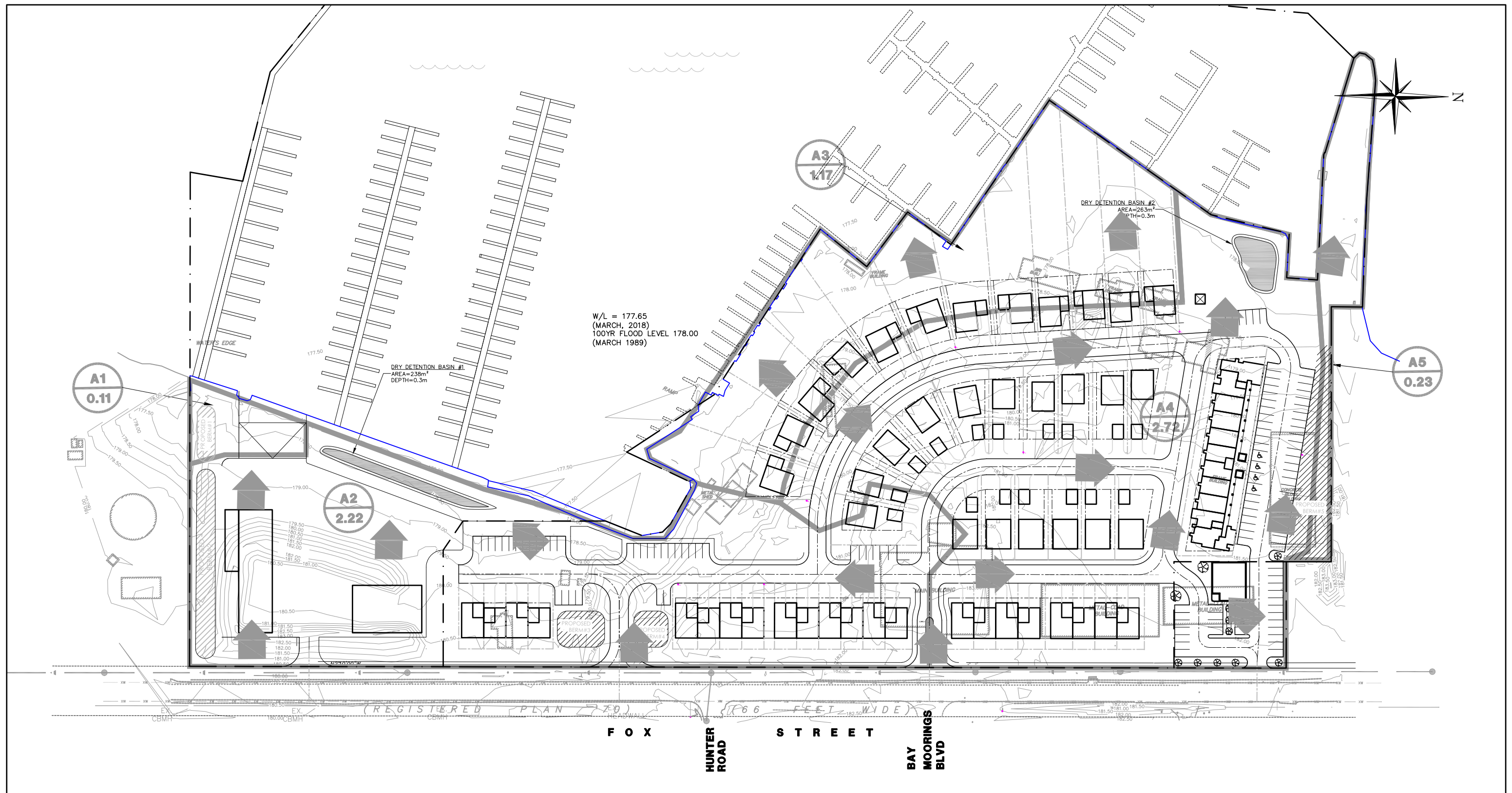

LEGEND:

- 0

CATCHMENT I.D.
- 0.00

DRAINAGE AREA (ha)
- CATCHMENT BOUNDARY
- RUNOFF FLOW DIRECTION

Drawing Title POST-DEVELOPMENT DRAINAGE PLAN
Project Title BAY MOORINGS MARINA

WMI & Associates Limited
119 Collier Street
Barrie, Ontario
L4M 1H5
705-797-2027
www.wmiengineering.ca

Drawn By BD	Checked By RDW	Figure No. FIG 3
Scale 1:1500	Project No. 17-392	

Key Plan:

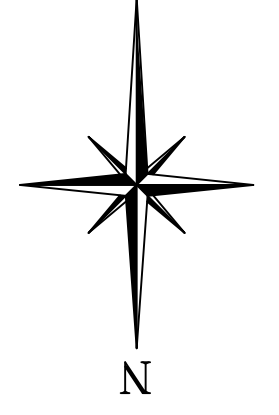

- Legend:**
- EXISTING FEATURES (EX)**
- EX SB EX STD IRON BAR
 - EX IB EX IRON BAR
 - EX UP EX UTILITY POLE
 - EX HBELL PED
 - EX HOBSD TRANSFORMER
 - GAS
 - EX U/G BELL
 - EX W/W WATERMAIN & VALVE
 - EX SWW EX SAN SEWER & MH
 - EX STMW EX STM SEWER & MH
 - EX WS EX WATER SERVICE
 - EX HVO EX FIRE HYD.
 - NS EX ST NAME SIGN
 - SS EX STOP SIGN
 - EX ELEVATION
 - EX FENCE
 - EX U/G GASMAIN
- PROPOSED FEATURES (PR)**
- PR STREET NAME SIGN
 - PR STOP SIGN
 - PR SILT FENCE
 - PR STREET LIGHT
 - PR WATER SERVICE
 - PR SAN SERVICE
 - PR SWW SERVICE
 - PR HYDRO TRANSFORMER
 - PR WATERMAIN
 - PR FIRE HYDRANT
 - PR WATER VALVE
 - PR SAN SEWER
 - PR SANITARY MANHOLE
 - PR SWW SEWER
 - PR CATCHBASIN MANHOLE
 - PR MANHOLE
 - PR CATCHBASIN
 - PROPOSED ELEVATION
 - PR MATCH EXISTING ELEVATION
 - PR SWALE

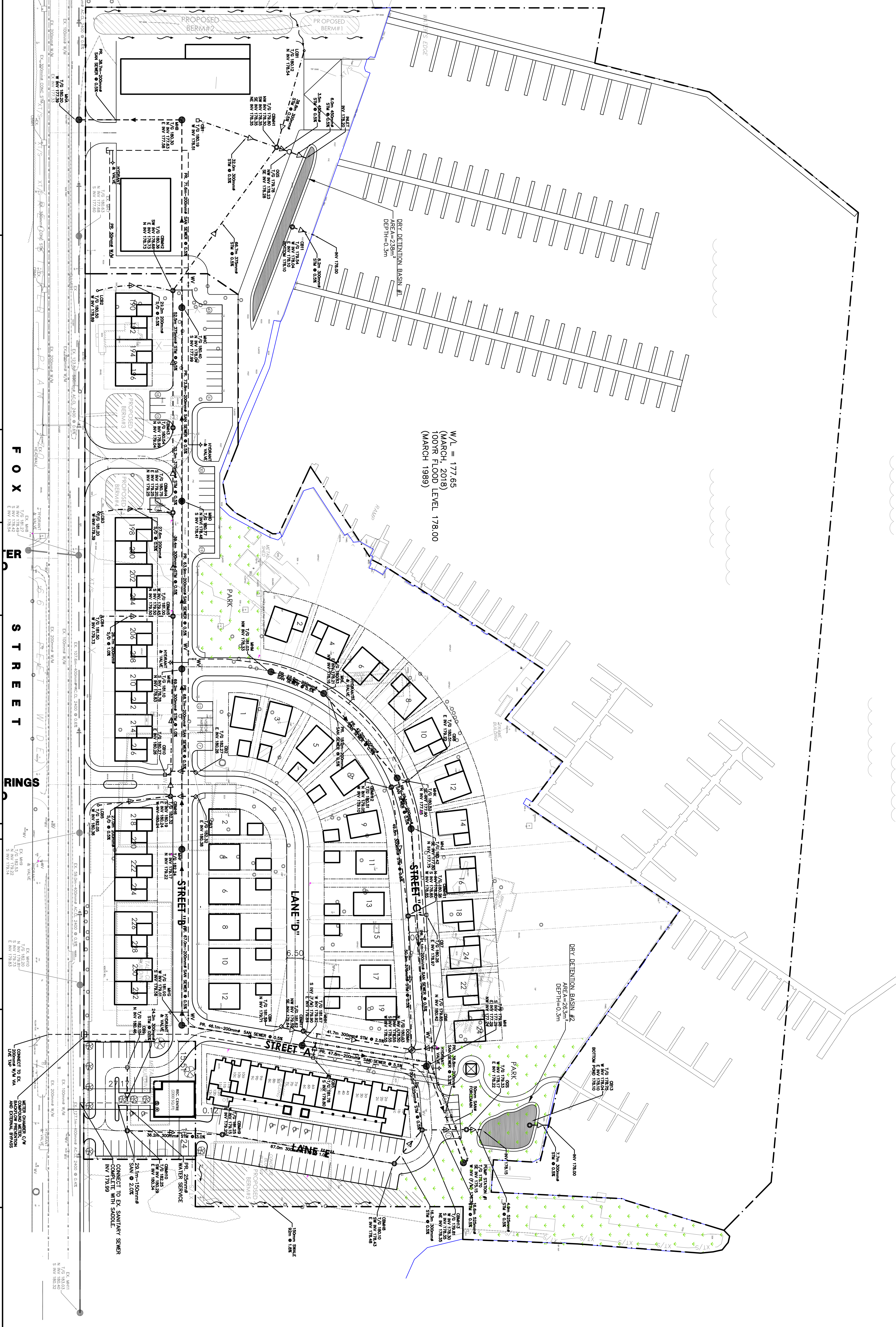

- Notes:**
1. Unless noted otherwise, the measurements and distances shown on this drawing are shown in meters.
 2. Do not scale drawings.
 3. It is the contractor's responsibility to verify all dimensions, levels and datum on site and report any discrepancies or omissions to WMI & Associates Ltd. prior to construction.
 4. This drawing is to be read and understood in conjunction with all other relevant documents applicable to this project.
 5. This drawing is the exclusive property of WMI & Associates Ltd. and the reproduction of any part of this document without prior written consent is strictly prohibited.

Benchmark: 180.16m
 TOWN OF PENETANGUISHENE BENCHMARK
 2010-2019 TOP OF SIB + CAP IN THE
 ECOLOGY GARDEN NEAR THE NW CORNER OF
 FOX STREET AND BECK BLVD. (23.7m WEST OF
 THE C/L OF FOX ST AND 8.7m NORTH OF THE
 C/L OF DRIVEWAY AT #159 FOX ST.)

No.	Issue / Revision	Date
1	ISS - 1ST SUBMISSION	FEB. 13, 2019

BAY MOORINGS MARINA
CONCEPTUAL SERVICING PLAN

Client:
 BAY MOORINGS MARINA
 HOLDINGS
 3280 Queen's Beach Road
 Midland, Ontario
 L4R 4K6

CAUTION
 CONTRACTOR TO DETERMINE
 LOCATION OF EXISTING UTILITIES
 PRIOR TO CONSTRUCTION.

WMI & Associates Limited
 110 Garden Street
 Midland, Ontario
 L4M 1H5
 Ph: 705-797-2027
 www.wmiengineering.ca

Drawn By: BD
 Created By: RWL
 Project No.: 17-592

FIG4

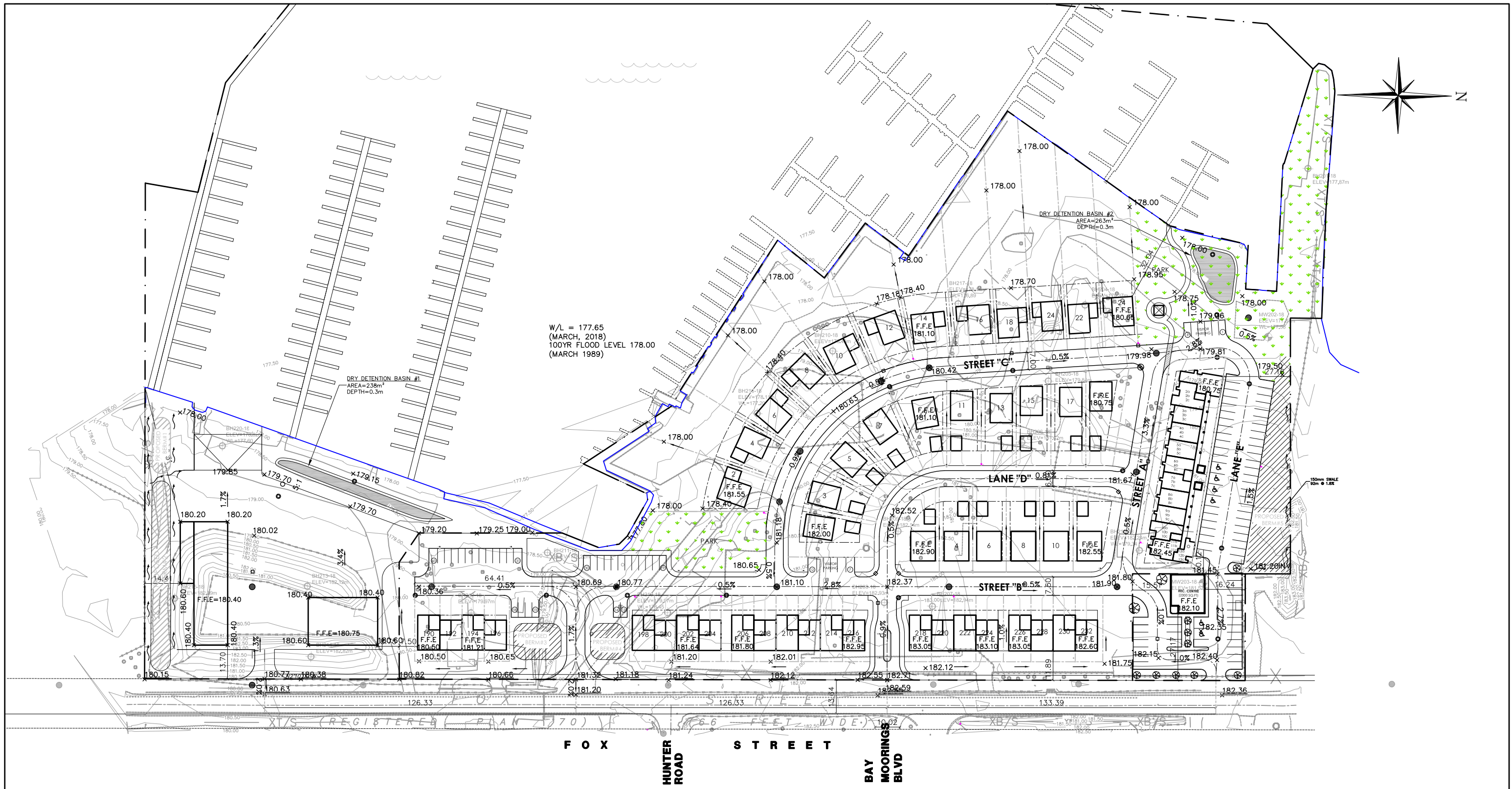

LEGEND:

- 000.00 PROPOSED ELEVATIONS
- 000.00 MATCH EX. ELEVATIONS
- 000.00 EXISTING CONTOUR LABELS
- ~ PROPOSED SWALE
- ⊕ BOREHOLE LOCATION
- 0.0% PROPOSED GRADE SLOPE
- F.F.E PR. FIRST FLOOR ELEVATION

Drawing Title	CONCEPTUAL GRADING PLAN	
Project Title	BAY MOORINGS MARINA	

WMI & Associates Limited
 119 Collier Street
 Barrie, Ontario
 L4M 1H5
 705-797-2027
 www.wmiengineering.ca

Drawn By	BD	Checked By	RDW	Figure No. FIG 5
Scale	1:1500	Project No.	17-392	

DEVELOPMENT CONCEPT PLAN

DATE: 19.01.25

SCALE: 1:1500

PENETANG HARBOUR

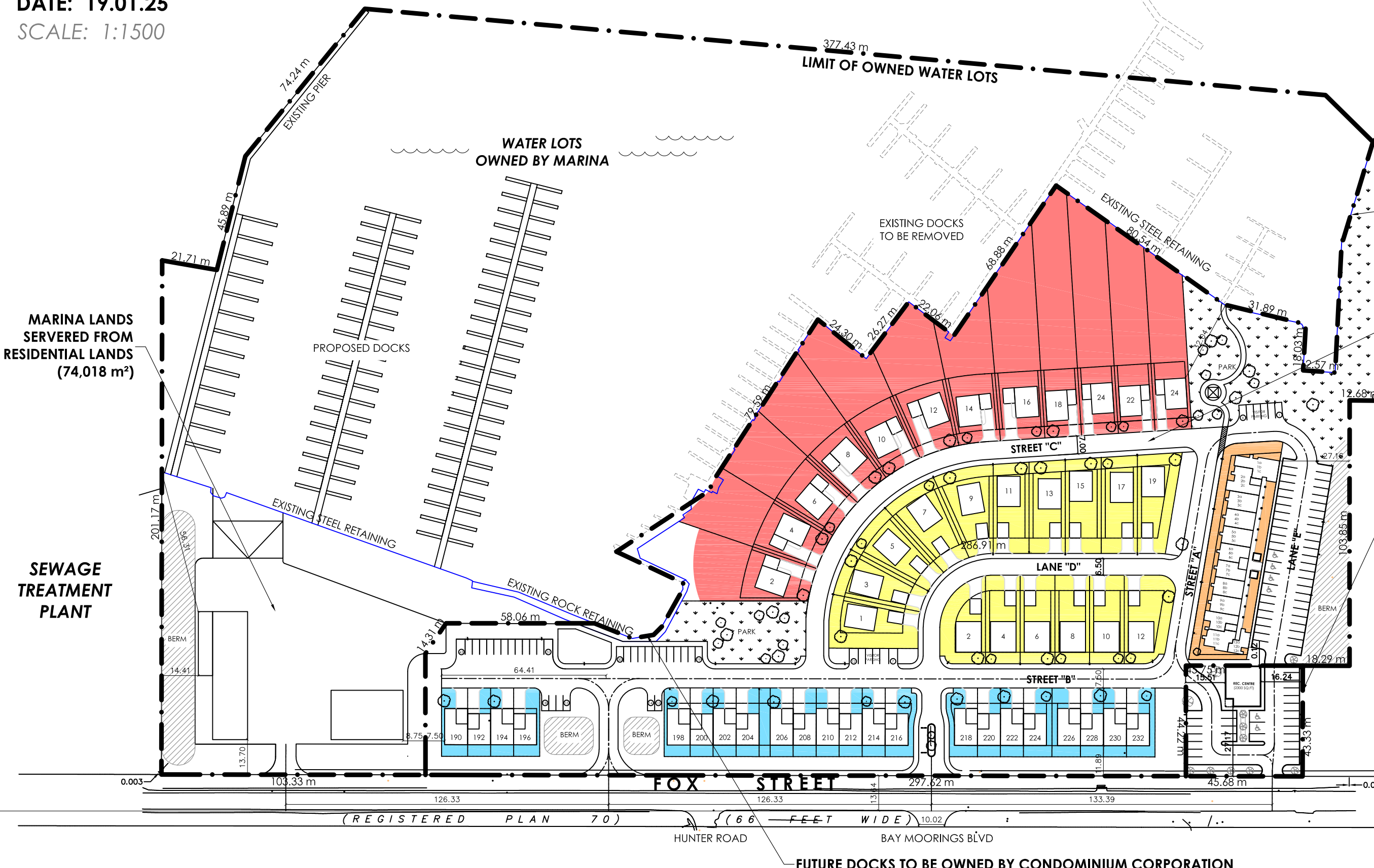
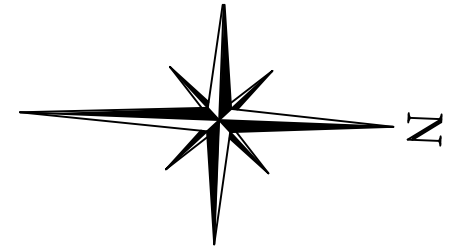

SHORE BOUNDARY AS PER SURVEY BY RODNEY G. REYNOLDS (NOV. 15 2018)

86 FREEHOLD LOTS WITH COMMON ELEMENTS CONDOMINIUM CORPORATION FOR ROADS / DOCKS / GREEN SPACE (53,136 m²)

MARINE COMMERCIAL

LAND TO BE SEVERED 1/2 ACRE (2,023 m²)

MARINA LANDS SEVERED FROM RESIDENTIAL LANDS (74,018 m²)

SEWAGE TREATMENT PLANT

FOX STREET

FUTURE DOCKS TO BE OWNED BY CONDOMINIUM CORPORATION

RESIDENTIAL

AREA TABLE	
	PROPOSED
MARINA LOT (m ²):	74,018
RECREATION CENTRE AREA (m ²):	2023
PROP. DEVELOPMENT AREA (m ²):	53,136
TOTAL SITE AREA (m ²):	129,177
PROPOSED LOT/YARD REG. FOR RESIDENTIAL LANDS	
LOT FRONTAGE (m):	297.62
LOT DEPTH (m):	146
EAST YARD SETBACK (m):	11.88
WEST YARD SETBACK (m):	38.74
NORTH YARD SETBACK (m):	27.16
SOUTH YARD SETBACK (m):	9.24
PROPOSED LOT/YARD REG. FOR RECREATION CENTRE	
LOT FRONTAGE (m):	45.68
LOT DEPTH (m):	43.33
EAST YARD SETBACK (m):	27.17
WEST YARD SETBACK (m):	0.12
NORTH YARD SETBACK (m):	16.24
SOUTH YARD SETBACK (m):	15.51
PROPOSED LOT/YARD REG. FOR MARINA LOT	
LOT FRONTAGE (m):	103.33
LOT DEPTH (m):	250.47
EAST YARD SETBACK (m):	13.70
WEST YARD SETBACK (m):	56.31
NORTH YARD SETBACK (m):	8.75
SOUTH YARD SETBACK (m):	14.41

APPENDIX B

CALCULATIONS



**RUNOFF COEFFICIENT CALCULATIONS
 "C" SPREADSHEET**

Date: 2019-01-31

Project No.: 17-392A

Project: Bay Moorings Marina

Prepared By: BD

Land Cover		Hydrologic Soil Groups		
		A-AB	B-BC	C-D
Cultivated Land	0 - 5% grade	0.22	0.35	0.55
	5 - 10% grade	0.3	0.45	0.6
	10 - 30% grade	0.4	0.65	0.7
Pasture Land	0 - 5% grade	0.1	0.28	0.4
	5 - 10% grade	0.15	0.35	0.45
	10 - 30% grade	0.22	0.4	0.55
Woodlot or Cutover	0 - 5% grade	0.08	0.25	0.35
	5 - 10% grade	0.12	0.3	0.42
	10 - 30% grade	0.18	0.35	0.52
Lakes and Wetlands		0.05	0.05	0.05
Impervious Area	(i.e. buildings, roads, parking lot, etc.)	0.95	0.95	0.95
Gravel	(not used for proposed parking or storage areas)	0.4	0.5	0.6
Residential	Single Family	0.3	0.4	0.5
	Multiple (i.e. semi, townhouse, apartment, etc.)	0.5	0.6	0.7
Industrial	Light	0.55	0.65	0.75
	Heavy	0.65	0.75	0.85
Commercial		0.6	0.7	0.8
Unimproved Areas		0.1	0.2	0.3
Lawn	< 2% grade	0.05	0.11	0.17
	2 - 7% grade	0.1	0.16	0.22
	> 7% grade	0.15	0.25	0.35

Ref: Runoff Coefficient Numbers - Adapted from Design Chart 1.07, Ontario Ministry of Transportation, "MTO Drainage Management Manual", MTO. (1997)

 <<< Elements Requiring Input Information

PRE-DEVELOPMENT CONDITION - SITE CATCHMENT NORTH

Land Cover		Hydrologic Soil Groups		
		A-AB	B-BC	C-D
Cultivated Land	0 - 5% grade			
	5 - 10% grade			
	10 - 30% grade			
Pasture Land	0 - 5% grade			
	5 - 10% grade			
	10 - 30% grade			
Woodlot or Cutover	0 - 5% grade	0.386		
	5 - 10% grade			
	10 - 30% grade			
Lakes and Wetlands				
Impervious Area	(i.e. buildings, roads, parking lot, etc.)	3.616		
Gravel	(not used for proposed parking or storage areas)			
Residential	Single Family			
	Multiple (i.e. semi, townhouse, apartment, etc.)			
Industrial	Light			
	Heavy			
Commercial				
Unimproved Areas				
Lawn	< 2% grade	0.628		
	2 - 7% grade			
	> 7% grade			

Total Area (ha) = 4.63

Runoff Coefficient, C = 0.76

PRE-DEVELOPMENT CONDITION - SITE CATCHMENT SOUTH

Land Cover		Hydrologic Soil Groups		
		A-AB	B-BC	C-D
Cultivated Land	0 - 5% grade			
	5 - 10% grade			
	10 - 30% grade			
Pasture Land	0 - 5% grade			
	5 - 10% grade			
	10 - 30% grade			
Woodlot or Cutover	0 - 5% grade	0.070		
	5 - 10% grade			
	10 - 30% grade			
Lakes and Wetlands				
Impervious Area	(i.e. buildings, roads, parking lot, etc.)	0.026		
Gravel	(not used for proposed parking or storage areas)	0.550		
Residential	Single Family			
	Multiple (i.e. semi, townhouse, apartment, etc.)			
Industrial	Light			
	Heavy			
Commercial				
Unimproved Areas				
Lawn	< 2% grade	0.924		
	2 - 7% grade			
	> 7% grade			

Total Area (ha) = 1.57

Runoff Coefficient, C = 0.19

POST-DEVELOPMENT CONDITION - SITE CATCHMENT A1

Land Cover		Hydrologic Soil Groups		
		A-AB	B-BC	C-D
Cultivated Land	0 - 5% grade			
	5 - 10% grade			
	10 - 30% grade			
Pasture Land	0 - 5% grade			
	5 - 10% grade			
	10 - 30% grade			
Woodlot or Cutover	0 - 5% grade			
	5 - 10% grade			
	10 - 30% grade			
Lakes and Wetlands				
Impervious Area	(i.e. buildings, roads, parking lot, etc.)	0.030		
Gravel	(not used for proposed parking or storage areas)			
Residential	Single Family			
	Multiple (i.e. semi, townhouse, apartment, etc.)			
Industrial	Light			
	Heavy			
Commercial				
Unimproved Areas				
Lawn	< 2% grade	0.080		
	2 - 7% grade			
	> 7% grade			

Total Area (ha) = 0.11

Runoff Coefficient, C = 0.30

POST-DEVELOPMENT CONDITION - SITE CATCHMENT A2

Land Cover		Hydrologic Soil Groups		
		A-AB	B-BC	C-D
Cultivated Land	0 - 5% grade			
	5 - 10% grade			
	10 - 30% grade			
Pasture Land	0 - 5% grade			
	5 - 10% grade			
	10 - 30% grade			
Woodlot or Cutover	0 - 5% grade			
	5 - 10% grade			
	10 - 30% grade			
Lakes and Wetlands				
Impervious Area	(i.e. buildings, roads, parking lot, etc.)	1.223		
Gravel	(not used for proposed parking or storage areas)			
Residential	Single Family			
	Multiple (i.e. semi, townhouse, apartment, etc.)			
Industrial	Light			
	Heavy			
Commercial				
Unimproved Areas				
Lawn	< 2% grade	0.997		
	2 - 7% grade			
	> 7% grade			

Total Area (ha) = 2.22

Runoff Coefficient, C = 0.55

POST-DEVELOPMENT CONDITION - SITE CATCHMENT A3

Land Cover		Hydrologic Soil Groups		
		A-AB	B-BC	C-D
Cultivated Land	0 - 5% grade			
	5 - 10% grade			
	10 - 30% grade			
Pasture Land	0 - 5% grade			
	5 - 10% grade			
	10 - 30% grade			
Woodlot or Cutover	0 - 5% grade			
	5 - 10% grade			
	10 - 30% grade			
Lakes and Wetlands				
Impervious Area	(i.e. buildings, roads, parking lot, etc.)	0.117		
Gravel	(not used for proposed parking or storage areas)			
Residential	Single Family			
	Multiple (i.e. semi, townhouse, apartment, etc.)			
Industrial	Light			
	Heavy			
Commercial				
Unimproved Areas				
Lawn	< 2% grade	1.053		
	2 - 7% grade			
	> 7% grade			

Total Area (ha) = 1.17

Runoff Coefficient, C = 0.14

POST-DEVELOPMENT CONDITION - SITE CATCHMENT A4

Land Cover		Hydrologic Soil Groups		
		A-AB	B-BC	C-D
Cultivated Land	0 - 5% grade			
	5 - 10% grade			
	10 - 30% grade			
Pasture Land	0 - 5% grade			
	5 - 10% grade			
	10 - 30% grade			
Woodlot or Cutover	0 - 5% grade			
	5 - 10% grade			
	10 - 30% grade			
Lakes and Wetlands				
Impervious Area	(i.e. buildings, roads, parking lot, etc.)	1.773		
Gravel	(not used for proposed parking or storage areas)			
Residential	Single Family			
	Multiple (i.e. semi, townhouse, apartment, etc.)			
Industrial	Light			
	Heavy			
Commercial				
Unimproved Areas				
Lawn	< 2% grade	0.947		
	2 - 7% grade			
	> 7% grade			

Total Area (ha) = 2.72

Runoff Coefficient, C = 0.64

POST-DEVELOPMENT CONDITION - SITE CATCHMENT A5

Land Cover		Hydrologic Soil Groups		
		A-AB	B-BC	C-D
Cultivated Land	0 - 5% grade			
	5 - 10% grade			
	10 - 30% grade			
Pasture Land	0 - 5% grade			
	5 - 10% grade			
	10 - 30% grade			
Woodlot or Cutover	0 - 5% grade			
	5 - 10% grade			
	10 - 30% grade			
Lakes and Wetlands				
Impervious Area	(i.e. buildings, roads, parking lot, etc.)			
Gravel	(not used for proposed parking or storage areas)			
Residential	Single Family			
	Multiple (i.e. semi, townhouse, apartment, etc.)			
Industrial	Light			
	Heavy			
Commercial				
Unimproved Areas				
Lawn	< 2% grade	0.230		
	2 - 7% grade			
	> 7% grade			

Total Area (ha) = 0.23

Runoff Coefficient, C = 0.05



RATIONAL METHOD CALCULATIONS

Date: 2019-01-31

Project No.: 17-392

Project: Bay Moorings Marina

Prepared By: BD

Elements Requiring Input Information

Rainfall Intensity-Duration-Frequency Coefficients from: http://www.mto.gov.on.ca/IDF_Curves/terms.shtml

2-year		5-year		10-year		25-year		50-year		100-year	
A =	21.4	A =	28.4	A =	33.0	A =	38.7	A =	43.0	A =	47.3
B =	-0.699	B =	-0.699	B =	-0.699	B =	-0.699	B =	-0.699	B =	-0.699

Rational Method Formula

$$Q = \frac{C \times I \times A}{360} \quad (\text{m}^3/\text{s})$$

where, C = Runoff Coefficient
 I = Rainfall Intensity, (mm/hr)
 A = Drainage Area, (ha)

Rainfall Intensity Equation (2-100 year storm events)

$$I_{2-100} = A \times (T_c / 60)^B \quad (\text{mm}/\text{hr})$$

where, A = Rainfall IDF Coefficient
 B = Rainfall IDF Coefficient
 T_c = Time of Concentration, (hr)

Runoff Coefficient Equations
 Based on MTO Drainage Manual (1984), page BD-4

2-year C₂ = C
 5-year C₅ = C
 10-year C₁₀ = C
 25-year C₂₅ = 1.10 x C
 50-year C₅₀ = 1.20 x C
 100-year C₁₀₀ = 1.25 x C

Rainfall Intensity Equation (25mm storm event)
 Based on the MOE SWMP Manual (2003), Eq'n 4.9

$$I_{25\text{mm}} = (43 \times C) + 5.9 \quad (\text{mm}/\text{hr})$$

where, C = Runoff Coefficient

For storms having a return period of more than 10 years, the Runoff Coefficient, C, will be increased as shown above up to a maximum coefficient of 0.95.

Catchment I.D.	A (ha)	T _c (min.)	C	Q _{25mm} (m ³ /s)	Q ₂ (m ³ /s)	Q ₅ (m ³ /s)	Q ₁₀ (m ³ /s)	Q ₂₅ (m ³ /s)	Q ₅₀ (m ³ /s)	Q ₁₀₀ (m ³ /s)
PRE NORTH	4.63	15.0	0.76	0.377	0.551	0.732	0.850	1.097	1.329	1.523
PRE SOUTH	1.57	15.0	0.19	0.012	0.047	0.062	0.072	0.093	0.113	0.129
POST A1	0.11	15.0	0.30	0.002	0.005	0.007	0.008	0.010	0.012	0.014
POST A2	2.22	15.0	0.55	0.100	0.191	0.254	0.295	0.381	0.461	0.528
POST A3	1.17	15.0	0.14	0.005	0.026	0.034	0.040	0.051	0.062	0.071
POST A4	2.72	15.0	0.64	0.162	0.273	0.362	0.421	0.542	0.658	0.753
POST A5	0.23	15.0	0.05	0.000	0.002	0.002	0.003	0.004	0.004	0.005

Notes: Post-development conditions propose less impervious area than pre-development conditions. This results in an overall reduction in stormwater flow in the post-development condition.
 Due to the small catchment sizes, the time of concentration was conservatively assumed to be 15.0 minutes.



Storm Sewer Design Sheet Bay Moorings Marina (Site Plan)

<<< Elements Requiring Input Information

Rational Method Calculation:

$$Q = 2.78 \cdot (C_p \cdot C \cdot I \cdot A)$$

where,

Q = peak flow rate (L/s)

C_p = runoff coefficient factor for storms > 10-yr (C_p = 1.0 for the 2, 5 & 10-yr storm events and

C = runoff coefficient

I = rainfall intensity (mm/hr)

A = area (ha)

(C_F = 1.1, 1.2 & 1.25 for the 25, 50 & 100-yr storm events respectively)

Manning's Formula Calculation:

$$V = (k \cdot R^{2/3} \cdot S^{1/2}) / n$$

$$Q = V \cdot A$$

MOE Velocity Requirements: 0.8m/s - 6.0m/s

where,

V = mean velocity (m/s)

k = 1.0 for SI units

R = hydraulic radius (m)

S = friction slope (m/m)

n = Mannings Coefficient

0.013

Rainfall Intensity Calculation:

$$I = A \cdot T^B$$

Rainfall IDF Data: http://www.mto.gov.on.ca/IDF_Curves/terms.shtml

where,

I = Rainfall Intensity (mm/hr)

T = Time of Concentration (hr)

A = Rainfall IDF Coefficient

B = Rainfall IDF Coefficient

	5-year	100-year
A =	28.1	47.1
B =	-0.699	-0.699

Runoff Coeff. Factors, C_F = 1.00 1.25

Date: 31-Jan-19

Project No: 17-392

Prepared by: AW

Location			Runoff Calculation Data										Sewer Calculation Data						Sewer Profile Data							
Street	Upstream MH	Downstream MH	Drainage Areas (ha)				Individual 2.78CA	Accumulated 2.78CA	Time of Concentration (mins)	Storm Event	Rainfall Intensity (mm/hr)	Peak Runoff Flow (L/s)	Diameter (mm)	Slope (%)	Length (m)	Capacity (L/s)	Velocity (m/s)	Pipe Flow Time (mins)	Pipe Storage Volume (m ³)	Fall in Sewer (m)	Drop in MH (m)		Top of Grate Elevation (m)		Invert Elevation (m)	
			C = 0.15	C = 0.30	C = 0.55	C = 0.65															DS	US	DS	US	DS	US
	CBMH6	CBMH5			0.15	0.23	0.23	15.00	5-year	74.05	16.76	300	1.00	69.20	100.88	1.38	0.83	5.0	0.69	0.05	182.32	181.00	180.19	179.50		
	CBMH5	CBMH4			0.34	0.53	0.75	15.83	5-year	71.30	53.64	300	0.50	39.40	71.33	0.98	0.67	2.9	0.20	0.05	181.00	180.75	179.45	179.25		
	CBMH4	CBMH3			0.18	0.27	1.03	16.51	5-year	69.26	71.06	375	0.50	32.20	129.34	1.13	0.47	3.7	0.16	0.05	180.75	180.54	179.20	179.04		
	CBMH3	CBMH2			0.16	0.24	1.27	16.98	5-year	67.91	86.08	375	0.50	52.50	129.34	1.13	0.77	6.0	0.26	0.05	180.54	180.36	178.99	178.73		
	CBMH2	CBMH1			0.32	0.49	1.76	17.75	5-year	65.83	115.86	375	0.50	66.70	129.34	1.13	0.98	7.6	0.33	0.05	180.36	179.80	178.68	178.35		
	CB1	CBMH1			0.21	0.33	0.33	15.00	5-year	74.05	24.23	300	0.50	32.00	71.33	0.98	0.55	2.3	0.16	0.05	180.19	179.80	178.51	178.35		
	CBMH1	OGS1			0.23	0.35	2.44	18.73	5-year	63.41	154.63	450	0.50	3.50	210.32	1.28	0.05	0.6	0.02	0.05	179.80	178.65	178.30	178.28		
	OGS1	INLET1			0.00	0.00	2.44	18.78	5-year	63.30	154.37	450	0.50	6.00	210.32	1.28	0.08	1.0	0.03	0.00	178.78	178.65	178.23	178.20		
	CB9	CBMH10			0.03	0.05	0.05	15.00	5-year	74.05	4.01	300	0.50	24.20	71.33	0.98	0.41	1.8	0.12	0.05	182.15	182.25	180.46	180.34		
	CBMH10	CBMH9			0.02	0.03	0.08	15.41	5-year	72.66	5.91	300	3.00	36.20	174.73	2.39	0.25	2.6	1.09	0.05	182.25	181.25	180.29	179.20		
	CBMH9	CBMH8			0.12	0.22	0.30	15.66	5-year	71.84	21.68	300	1.00	67.00	100.88	1.38	0.81	4.9	0.67	0.05	181.25	180.10	179.15	178.48		
	CBMH8	CBMH13			0.25	0.45	0.75	16.47	5-year	69.36	51.89	300	0.50	16.30	71.33	0.98	0.28	1.2	0.08	0.05	180.10	179.81	178.43	178.35		
	CBMH7	DCBMH			0.86	1.56	1.56	15.00	5-year	74.05	115.25	300	2.50	41.70	159.51	2.19	0.32	3.0	1.04	0.05	181.62	180.03	179.59	178.55		
	CBMH12	CBMH11			0.35	0.63	0.63	15.00	5-year	74.05	46.57	300	0.50	49.80	71.33	0.98	0.85	3.6	0.25	0.05	180.51	180.26	179.10	178.85		
	CBMH11	DCBMH			0.28	0.51	1.14	15.85	5-year	71.26	81.12	375	0.50	50.90	129.34	1.13	0.75	5.8	0.25	0.05	180.26	180.03	178.80	178.55		
	DCBMH	CBMH13			0.41	0.75	3.44	16.60	5-year	69.00	237.43	525	0.50	30.20	317.25	1.42	0.35	6.7	0.15	0.05	180.03	179.81	178.50	178.35		
	CBMH13	OGS2			0.05	0.09	4.28	16.95	5-year	67.99	290.95	525	0.50	16.30	317.25	1.42	0.19	3.6	0.08	0.05	179.81	179.23	178.30	178.22		
	OGS2	INLET2			0.00	0.00	4.28	17.14	5-year	67.45	288.67	525	0.50	4.90	317.25	1.42	0.06	1.1	0.02	0.00	179.23	178.68	178.17	178.15		

Sum of Drainage Areas (ha): 0.00 0.00 1.60 2.37
 Total Drainage Area (ha): 3.96

NOTES:



TOTAL DAILY DOMESTIC WATER SUPPLY FLOW CALCULATIONS
 Bay Moorings Marina, 160-200 Fox Street, Penetanguishene, Ontario

Date: 06-Feb-19

Project No.: 17-392

Project: Bay Moorings Marina

Prepared By: BD

<<< Elements Requiring Input Information

Total Daily Design Flow Calculations

References: - Ontario Building Code (OBC), 2012, Division B, Part 8, Table 8.2.1.3.A. Residential Occupancy & Table 8.2.1.3.B. Other Occupancies
 - Ministry of the Environment (MOE), Design Guidelines for Drinking-Water Systems (2008), Chapter 3

Proposed Condition:

Establishment:	# of people	# of water closets	# of loading bays	# of seats	Gross Floor Area (m ²)	Land Area (ha)	Total Daily Design Volume	Avg Day Demand ADD (L/s)	Max Day Demand MDD (L/s)	Peak Hourly Demand PHD (L/s)	
Commercial/Institutional & Industrial Uses:											
Marina Building*					545.0		75	L/9.3m ²	0.051	0.076	0.153
Marina Warehouse**		2					950	L/water closet	0.022	0.033	0.066
Marina Warehouse**			2				150	L/loading bay	0.003	0.005	0.010
Recreational Centre*					214.0		75	L/9.3m ²	0.020	0.030	0.060
Subtotal =		2	2		759				0.096	0.144	0.289
								Peaking Factor =	1.5	3	
Residential Uses:											
Townhouses (22 units @ 3 bedrooms/unit)	132						275	L/person	0.42	1.29	1.94
Condominium (36 units @ 3 bedrooms/unit)	216						275	L/person	0.69	2.11	3.17
Dwellings (28 units @ 3ppu)	84						450	L/person	0.44	1.34	2.02
Subtotal =	432								1.55	4.74	7.12
								Peaking Factor =	3.07	4.61	

Refer to Table 3-1 and/or Table 3.3 of the MOE Design Guidelines for Drinking-Water Systems (2008) >>>

Notes:

- * - To be conservative, it has been assumed that the Marina Building and Recreational Centre will have flows similar to an Office Building.
- ** - To be conservative, it has been assumed that there will be 2 water closets and 2 loading bays in the proposed Marina Warehouse.



**FIRE PROTECTION WATER STORAGE
 DESIGN CALCULATIONS: RESIDENTIAL**

Date: 16-Nov-18

Project No.: 17-392

Project: Bay Moorings Marina

Prepared By: BD



<<< Elements Requiring Input Information

Fire Protection Water Storage

Reference: Office of the Fire Marshal, OFM Guideline, Fire Protection Water Supply Guideline for Part 3 in the Ontario Building Code (OBC), October 1999
 Subsection 3.2.2 of the Ontario Building Code, 2012

Calculate $Q=KVS_{TOTAL}$

Building Classification:

The proposed residential units are Group 'C', residential occupancies
 It has been assumed that the building will be constructed with combustible materials and in accordance with Subsection 3.2.2. of the OBC.

Therefore, based on Table 1 of OBC A.3.2.5.7., Water Supply Coefficient, K:

$K = 23$

Approximate Building Volume:

(All space below and above grade within the building, measured to the underside of the roof deck, including basements and crawl spaces.)

$V = \text{Area} \times \text{Height} + \text{Roof Volume}$
 (2 storey townhouse bldg. based on typ. storey height of 2.60m)

$= 110 \text{ m}^2 \times 2.6 \text{ m} \times 2 \text{ stories} + 91 \text{ m}^3$
 roof volume (assumed 13.9m x 7.9m footprint; 5:12 pitch gable roof)

$V = 662.6 \text{ m}^3$

Approximate Exposure Distance From Proposed Buildings To:

(Exposure distances from a new building are measured from the exterior building faces to the property lines of the building. When facing a street, the property line shall be deemed to be the center of the street. When facing an existing building (exceeding 10 m² in building area) on the same property, the exposure distance shall be the greater of either the "limiting distance" of the new building face as obtained from Sentence 3.2.3.1.(1) of the Building Code, or the mid-point between the two buildings.)

West to Pr Street =	13.0	m
North to Pr Street >=	20.0	m
East to Pr Bldg =	0.0	m
South to Pr Street >=	11.5	m

from Figure 1 (OBC, A.3.2.5.7.)

$S_W =$	0
$S_N =$	0
$S_E =$	0
$S_S =$	0

(firewall assumed between attached buildings)

$S_{TOTAL} = 1 + (S_W + S_N + S_E + S_S)$
 $= 1 + 0$
 $S_{TOTAL} = 1$ (max. allowable is 2.0)

Minimum Water Supply,

$Q = KVS_{TOTAL}$
 $= 23 \times 662.6 \times 1$
 $Q = 15,240 \text{ L}$

Check

$Q_{CHECK} = 2700 \text{ L/min} \times 30 \text{ min}$
 $Q_{CHECK} = 81,000 \text{ L}$

$Q_{TOTAL} = \text{greater of } Q \text{ \& } Q_{CHECK}$

$Q_{TOTAL} = 81,000 \text{ L}$

where,
 Q = Minimum Water Supply (L)
 K = Water Supply Coefficient
 V = Building Volume (m³)
 S_{TOTAL} = Total Spatial Coefficient

Water supply will be entirely provided by the proposed watermain.

Minimum Water Supply Flow Rate:

From Table 2, Required Minimum Water Supply Flow Rate (L/min), provided in the OBC A.3.2.5.7.,

Flow Rate = 2700 L/min



**FIRE PROTECTION WATER STORAGE
 DESIGN CALCULATIONS: MARINA WAREHOUSE**

Date: 06-Feb-19

Project No.: 17-392

Project: Bay Moorings Marina

Prepared By: BD



<<< Elements Requiring Input Information

Fire Protection Water Storage

Reference: Office of the Fire Marshal, OFM Guideline, Fire Protection Water Supply Guideline for Part 3 in the Ontario Building Code (OBC), October 1999
 Subsection 3.2.2 of the Ontario Building Code, 2012

Calculate $Q=KVS_{TOTAL}$

Building Classification:

The proposed warehouse is a Group 'F' industrial occupancy. It has been assumed that the building will be constructed with combustible materials and in accordance with Subsection 3.2.2. of the OBC.

Therefore, based on Table 1 of OBC A.3.2.5.7., Water Supply Coefficient, K:

$K = 23$

Approximate Building Volume:

(All space below and above grade within the building, measured to the underside of the roof deck, including basements and crawl spaces.)

$V = \text{Area} \times \text{Height} + \text{Roof Volume}$
 (2 storey warehouse bldg. based on typ. storey height of 2.60m)

$= 825 \text{ m}^2 \times 2.6 \text{ m} \times 2 \text{ stories} + 1022 \text{ m}^3$
 roof volume (assumed 50m x 14.0m footprint; 5:12 pitch gable roof)

$V = 5312.0 \text{ m}^3$

Approximate Exposure Distance From Proposed Buildings To:

(Exposure distances from a new building are measured from the exterior building faces to the property lines of the building. When facing a street, the property line shall be deemed to be the center of the street. When facing an existing building (exceeding 10 m² in building area) on the same property, the exposure distance shall be the greater of either the "limiting distance" of the new building face as obtained from Sentence 3.2.3.1.(1) of the Building Code, or the mid-point between the two buildings.)

West to P/L =	14.1	m
North to P/L >=	100.0	m
East to Pr Bldg =	32.6	m
South to P/L >=	33.7	m

from Figure 1 (OBC, A.3.2.5.7.)

$S_W =$	0
$S_N =$	0
$S_E =$	0
$S_S =$	0

$S_{TOTAL} = 1 + (S_W + S_N + S_E + S_S)$
 $= 1 + 0$
 $S_{TOTAL} = 1$ (max. allowable is 2.0)

Minimum Water Supply,

$Q = KVS_{TOTAL}$
 $= 23 \times 5312.0 \times 1$
 $Q = 122,176 \text{ L}$

Check

$Q_{CHECK} = 3600 \text{ L/min} \times 30 \text{ min}$
 $Q_{CHECK} = 108,000 \text{ L}$

$Q_{TOTAL} = \text{greater of } Q \text{ \& } Q_{CHECK}$

$Q_{TOTAL} = 122,176 \text{ L}$

where, Q = Minimum Water Supply (L)
 K = Water Supply Coefficient
 V = Building Volume (m³)
 S_{TOTAL} = Total Spatial Coefficient

Water supply will be entirely provided by the proposed watermain.

Minimum Water Supply Flow Rate:

From Table 2, Required Minimum Water Supply Flow Rate (L/min), provided in the OBC A.3.2.5.7.,

Flow Rate = 3600 L/min



Hydrant Flow Curve Detailed Report - Hydrant Flow Curve - 35

Element Details

Label	Hydrant Flow Curve - 35	Nominal Hydrant Flow	3,785.412 L/min
Hydrant/Junction	H025A	Number of Intervals	10

Time (hours)
7.000
13.000

7.000 hours Flow (L/min)	7.000 hours Pressure (psi)	13.000 hours Flow (L/min)	13.000 hours Pressure (psi)
0.000	89	0.000	88
378.541	88	378.541	87
757.082	87	757.082	86
1,135.624	86	1,135.624	86
1,514.165	86	1,514.165	85
1,892.706	85	1,892.706	84
2,271.247	84	2,271.247	83
2,649.788	83	2,649.788	81
3,028.329	81	3,028.329	80
3,406.870	80	3,406.870	78
3,785.412	78	3,785.412	76
4,163.953	76	4,163.953	75
4,542.494	74	4,542.494	73
4,921.035	72	4,921.035	70
5,299.577	69	5,299.577	68
5,678.118	67	5,678.118	65
6,056.659	64	6,056.659	63
6,435.200	61	6,435.200	60
6,813.741	58	6,813.741	57
7,192.282	55	7,192.282	54
7,570.823	52	7,570.823	51
7,949.365	49	7,949.365	47
8,327.906	45	8,327.906	44
8,706.447	41	8,706.447	40
9,084.988	37	9,084.988	36
9,463.530	33	9,463.530	31
9,842.071	28	9,842.071	27
10,220.612	23	10,220.612	22
10,599.153	18	10,599.153	16
10,977.694	13	10,977.694	11
11,356.235	7	11,356.235	5
11,734.777	2	11,723.172	0

Hydrant Flow Curve Detailed Report - Hydrant Flow Curve - 35

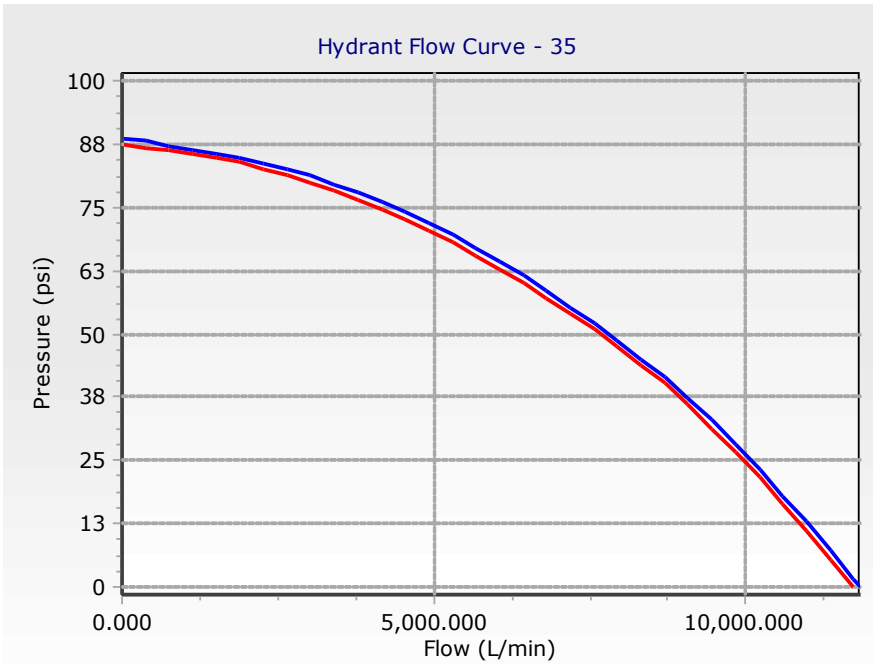

Hydrant Flow Curve Detailed Report - Hydrant Flow Curve - 36

Element Details

Label	Hydrant Flow Curve - 36	Nominal Hydrant Flow	3,785.412 L/min
Hydrant/Junction	H026A	Number of Intervals	10

Time (hours)
7.000
15.000

7.000 hours Flow (L/min)	7.000 hours Pressure (psi)	15.000 hours Flow (L/min)	15.000 hours Pressure (psi)
0.000	90	0.000	89
378.541	89	378.541	89
757.082	89	757.082	88
1,135.624	88	1,135.624	87
1,514.165	87	1,514.165	86
1,892.706	85	1,892.706	85
2,271.247	84	2,271.247	83
2,649.788	82	2,649.788	81
3,028.329	80	3,028.329	79
3,406.870	78	3,406.870	77
3,785.412	76	3,785.412	74
4,163.953	73	4,163.953	72
4,542.494	71	4,542.494	69
4,921.035	68	4,921.035	66
5,299.577	65	5,299.577	63
5,678.118	61	5,678.118	60
6,056.659	57	6,056.659	56
6,435.200	54	6,435.200	53
6,813.741	50	6,813.741	49
7,192.282	45	7,192.282	45
7,570.823	41	7,570.823	40
7,949.365	36	7,949.365	36
8,327.906	31	8,327.906	31
8,706.447	27	8,706.447	26
9,084.988	22	9,084.988	21
9,463.530	16	9,463.530	16
9,842.071	11	9,842.071	10
10,220.612	5	10,220.612	5
10,570.893	0	10,535.860	0

Marina Warehouse
 Required Flow = 3605L/min
 Actual Flow (Interpolated) = 75.47psi

Residential - Condominium
 Required Flow = 6305L/min
 Actual Flow (Interpolated) = 54.07psi

Hydrant Flow Curve Detailed Report - Hydrant Flow Curve - 36

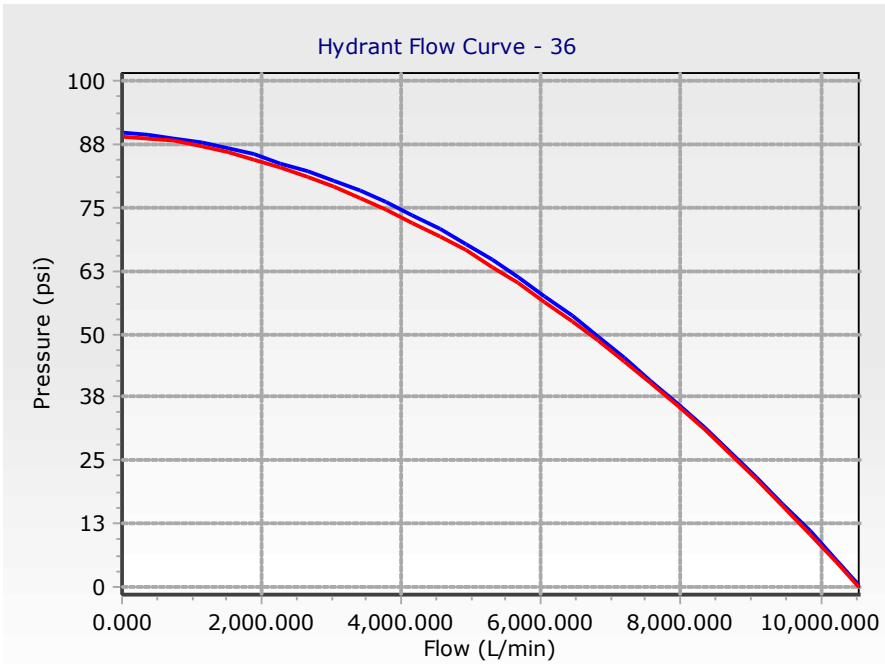



Watermain Headloss Calculations Bay Moorings Marina - Residential

<<< Elements Requiring Input Information

Velocity, $V = \frac{Q}{A}$ (m/s)
 where, $Q = \text{Flow (m}^3/\text{s)}$
 $A = \text{Cross-Sectional Area (m}^2)$
 Minor Head Loss, $H_L = (K_1+K_2+K_3\dots) \times V^2/2g$
 where, $\sum K = (K_1+K_2+K_3\dots)$
 $V = \text{mean velocity (m/s)}$
 $g = 9.81 \text{ (acceleration due to gravity, m/s}^2)$

Hazen -Williams Equation (re-arranged for Friction Slope)
 (Friction Head Loss Calculation)
 Friction Slope, $S = \frac{(V)^{1/0.54}}{(0.85CR)^{0.63, 1/0.54}} \times 100 \text{ (m/100m)}$
 where, $V = \text{mean velocity (m/s)}$
 $k = 0.85 \text{ for SI units}$
 $C = \text{Roughness Coefficient}$
 $R = \text{hydraulic radius (m)}$

Total Head Loss = Friction Head Loss + Minor Head Loss
 Pressure (psi) = Pressure Head (m) x 1.422
 Total HGL = Ground Elev. + Pressure Head

Date: 06-Feb-19
 Project No: 17-392
 Prepared by: BD

Description	Pipe Design Coefficient C	Forcemain						Sum of Minor Loss Coeff. $\sum K =$	Minor Head Loss (m)	Total Head Loss (m)	Total Pressure Loss (psi)	Pressure @ Pt. A (psi)	Pressure Head @ Pt. A (m)	Ground Elev. @ Pt. A (m)	Total HGL @ Pt. A (m)	Ground Elev. @ Pt. B (m)	Total HGL @ Pt. B (m)	Pressure Head @ Pt. B (m)	Pressure @ Pt. B (psi)
		Flow (L/s)	Diameter (mm)	Velocity (m/s)	Unit Friction Head Loss (m/100m)	Distance (m)	Friction Head Loss (m)												
WATERMAIN SIZING: (Residential)* A (i) Internal 200mm W/M (Connection Point to Hydrant at Street A / Street C Intersection)	110	109.88	200	3.50	7.50	153.00	11.48	1.35	0.84	12.32	17.52	54.07	38.02	182.45	220.47	179.98	208.15	28.17	40.06
WATERMAIN SIZING: (Commercial)** B (ii) Internal 200mm W/M (Connection Point to Hydrant at Southernmost Site Entrance)	110	64.88	200	2.07	2.83	426.25	12.05	1.80	0.39	12.45	17.70	75.47	53.07	182.45	235.52	180.60	223.08	42.48	60.40

NOTES: - (A) Loss Coefficient: 1 - 90° Bends @ K=1
 1 - Tee (Flow in line) @ K=0.35
 - (B) LC: 1 - 90° Bends @ K=1
 1 - Tee (Line to branch 90°) @ K=0.8

*Fire flow (FF) of 105 L/s and the Max. Daily Demand (MDD) of 4.88 L/s were added to determine the pressure loss within the Internal 200mm W/M under the FF + MDD conditions (109.88 L/s)

**Fire flow (FF) of 60 L/s and the Max. Daily Demand (MDD) of 4.88 L/s were added to determine the pressure loss within the Internal 200mm W/M under the FF + MDD conditions (64.88 L/s)

(i) As per the Hydrant Flow Curve Detailed Report provided by the Town of Penetanguishene (Oct. 18, 2018), a static pressure of 54.07 psi at a ground elevation of 182.45m is to be used at the connection point along Fox Street.

(ii) As per the Hydrant Flow Curve Detailed Report provided by the Town of Penetanguishene (Oct. 18, 2018), a static pressure of 75.47 psi at a ground elevation of 182.45m is to be used at the connection point along Fox Street.



Sanitary Sewer Design Sheet Bay Moorings Marina

<<< Elements Requiring Input Information

<p>Peak Flow Formulae: $Q_{pop} = (P \cdot q \cdot M) / 86.4$ (L/s) $Q_{Comm/Inst} = \text{Design Flow} \times \text{Peaking Factor}$ (L/s) $Q_{Ind} = \text{Design Flow} \times \text{Peaking Factor}$ (L/s) $Q_{Infil} = i \cdot A$ (L/s), where A = Area (ha) $Q_d = Q_{pop} + Q_{Comm/Inst} + Q_{Ind} + Q_{Infil}$ (L/s)</p> <p>MOE Velocity Requirements: 0.6m/s - 3.0m/s</p>	<p>where, P = population in 1000's q = residential sewage unit flow rate M = Ultimate Flow Factor (residential peaking factor) (Harmon) $M = 1 + (14 / (4 + P^{0.5}))$ Q_{pop} = peak population flow (L/s) $Q_{Comm/Inst}$ = peak commercial/institutional flow (L/s) Q_{Ind} = peak industrial flow (L/s) Q_{Infil} = peak extraneous (i.e. infiltration) flow (L/s) i = peak extraneous (i.e. infiltration) unit flow rate Q_d = total peak design flow (L/s)</p>	<p>Comm/Inst Peaking Factor: 1.5 Industrial Peaking Factor: 2 Res - SFD Single Family Dwellings: q: 450 L/cap./day ppd = 3 Res - MFD Multi-Family Dwellings: q: 275 L/cap./day ppu = 6</p> <p>Infiltration i: 0.19 L/s/ha (as per MOE Guidelines use 0.19 for sewer design & 0.04 (avg) - 0.11 (peak) for PS/STS)</p> <p>Mannings Coefficient n: 0.013</p>
---	---	--

Date: 11-Feb-19
Project No: 17-392A
Prepared by: BD

Location			Sewage Flow Calculation Data											Sewer Calculation Data					Sewer Profile Data											
Street	Upstream MH	Downstream MH	Res - SFD # of Units	Res - SFD # of People	Res - MFD # of Units	Res - MFD # of People	Comm/Inst Total Daily Flow (L/day)	Industrial Total Daily Flow (L/day)	Cum. Res - SFD # of People	Cum. Res - MFD # of People	Cum. Comm/Inst Total Daily Flow (L/day)	Cum. Industrial Total Daily Flow (L/day)	Residential Peaking Factor	Sewage Flow (L/s)	Infiltration			Total Flow (L/s)	Dia. (mm)	Slope (%)	Length (m)	Capacity (L/s)	Velocity (m/s)	Fall in Sewer (m)	Drop in MH (m)		Top of Grate Elevation (m)		Invert Elevation (m)	
															Individual Area (ha)	Cumulative Area (ha)	Flow (L/s)								DS	US	DS	US	DS	US
	MHM	MHL	4	12		0			12	0	0	0	4.41	0.28	0.09	0.09	0.02	0.29	200	0.50	23.2	24.19	0.75	0.12	0.05	181.03	180.83	178.33	178.21	
	MHL	MHK	5	15		0			27	0	0	0	4.36	0.61	0.15	0.24	0.05	0.66	200	0.50	42.2	24.19	0.75	0.21	0.05	180.83	180.52	178.16	177.95	
	MHK	MHJ	2	6		0			33	0	0	0	4.35	0.75	0.16	0.40	0.08	0.82	200	0.50	19.1	24.19	0.75	0.10	0.05	180.52	180.42	177.90	177.80	
	MHJ	MHI	11	33		0			66	0	0	0	4.29	1.47	0.29	0.69	0.13	1.61	200	0.50	91.1	24.19	0.75	0.46	0.05	180.42	179.98	177.75	177.29	
	MHH W	MHI		0	36	216			0	216	0	0	4.14	2.85	0.15	0.15	0.03	2.87	200	5.50	47.8	80.24	2.47	2.63	0.05	181.67	179.98	179.92	177.29	
	MHI	PS1		0		0			66	216	0	0	4.09	4.22	0.12	0.96	0.18	4.40	200	5.20	40.1	78.03	2.41	2.09		179.98	178.70	177.24	175.15	
	PS1*	MHH E		0		0			66	216	0	0	4.09	4.22	0.00	0.96	0.18	4.40	200											
	MHH E	MHG	22	66		0			132	216	0	0	4.05	5.57	0.13	1.09	0.21	5.78	200	0.50	46.1	24.19	0.75	0.23	0.05	181.67	181.90	179.84	179.61	
	MHG	MHF	5	15	6	36	700		147	252	700	0	4.02	6.31	0.24	1.33	0.25	6.57	200	0.50	67.0	24.19	0.75	0.34	0.05	181.90	182.24	179.56	179.22	
	MHF	MHE	1	3	6	36			150	288	700	0	4.00	6.80	0.23	1.56	0.30	7.10	200	0.50	67.0	24.19	0.75	0.34	0.05	182.24	181.10	179.17	178.83	
	MHE	MHD		0	6	36			150	324	700	0	3.99	7.24	0.18	1.74	0.33	7.57	200	0.50	63.9	24.19	0.75	0.32	0.05	181.10	180.77	178.78	178.46	
	MHD	MHC		0	3	18			150	342	700	0	3.98	7.45	0.20	1.94	0.37	7.82	200	0.50	73.8	24.19	0.75	0.37	0.05	180.77	180.40	178.41	178.04	
	MHC	MHB		0	1	6	1750		150	348	2450	0	3.98	7.56	0.14	2.08	0.40	7.96	200	0.50	71.6	24.19	0.75	0.36	0.05	180.40	180.30	177.99	177.63	
	MHB	MHA		0		0	2800		150	348	5250	0	3.98	7.61	0.06	2.14	0.41	8.02	200	0.50	38.7	24.19	0.75	0.19	0.06	180.30	180.20	177.58	177.39	

Individual Totals: 150
Cumulative # of People (SFD + MFD): 498

2.14

NOTES: - # of people for the Multi-Family Residential Dwellings (Townhouses, apartments, etc.) is calculated based on # of units x population density (people per unit = # of bedrooms x 2 people per bedroom).
- # of people for the Single-Family Residential Dwellings is calculated based on # of dwellings x population density (people per dwelling).
- Due to the rise in elevation between PS1 and MHN E, the spreadsheet will not function as intended for downstream manholes with inverts at higher elevations. For calculation purposes, the total number of units contributing up to PS1 was entered into MHN E to conservatively account for all contributing flows.

APPENDIX C

**GEOTECHNICAL INVESTIGATION /
HYDROGEOLOGICAL STUDY**



FOX STREET PENETANGUISENE PROPOSED DEVELOPMENT

Geotechnical Investigation

Project Location:

160 - 200 Fox Street
Penetanguishene, ON

Prepared for:

Wilmington Capital Management Inc.
505 3rd Street SW, Suite 700
Calgary, AB

Prepared by:

MTE Consultants Inc.
365 Home Street
Stratford, ON N5A 2A5

September 4, 2018

MTE File No.: 43022-100



TABLE OF CONTENTS

1.0	INTRODUCTION	1
2.0	CONCURRENT WORK.....	1
3.0	FIELD AND LABORATORY PROGRAM	1
4.0	SOIL CONDITIONS.....	3
4.1	Asphaltic Concrete and Fill.....	3
4.2	Silt / Silt and Clay.....	3
4.3	Sand	4
5.0	GROUNDWATER CONDITIONS	5
6.0	DISCUSSION AND RECOMMENDATIONS	5
6.1	General.....	5
6.2	Site Preparation	6
6.3	Site Servicing	7
6.3.1	<i>Excavations and Dewatering</i>	<i>7</i>
6.3.2	<i>Pipe Bedding</i>	<i>8</i>
6.3.3	<i>Groundwater Cutoffs.....</i>	<i>8</i>
6.3.4	<i>Trench Backfilling</i>	<i>8</i>
6.3.5	<i>Manholes</i>	<i>9</i>
6.4	Pavements	9
6.5	Curbs, Gutter and Sidewalks	10
6.6	Residential Foundation Design	11
6.7	Concrete Slab-on-Grade Floors.....	12
6.8	Stormwater Infiltration.....	12
7.0	LIMITATIONS OF REPORT.....	13

TABLES

TABLE 1 - RESULTS OF SILT AND CLAY PARTICLE SIZE DISTRIBUTION ANALYSES	3
TABLE 2 - RESULTS OF SILT AND CLAY ATTERBERG LIMITS TESTS	4
TABLE 3 - RESULTS OF SAND PARTICLE/GRAIN SIZE DISTRIBUTION ANALYSES	4
TABLE 4 - GROUNDWATER DEPTHS AND ELEVATIONS UPON COMPLETION OF DRILLING.....	5
TABLE 5 - ENGINEERED FILL REQUIREMENTS	6
TABLE 6 - PAVEMENT DESIGN	9

APPENDICES

APPENDIX A	FIGURES
APPENDIX B	BOREHOLE LOGS
APPENDIX C	LABORATORY TEST RESULTS
APPENDIX D	TENSAR INTERNATIONAL CORPORATION PRODUCT INFORMATION
APPENDIX E	EBS GEOSTRUCTURAL INC. HELICAL PILE INFORMATION

1.0 INTRODUCTION

MTE Consultants Inc. (MTE) was retained by Wilmington Capital Management Inc. to conduct a geotechnical investigation for a proposed development at Municipal Numbers 160 to 200 along Fox Street in Penetanguishene, Ontario. The site is located west of Fox Street, as shown on **Figure 1 in Appendix A**. The development will involve 60 total units including 28 single detached residential buildings, 6 semi-detached residential buildings, and 26 townhomes, as per the Travis and Associates Incorporated Site Plan SP-3, dated March 2018. It is noted a future recreation centre is planned for the northeast corner of the site and additional investigation is recommended in this area once design details are known.

The site is currently the Bay Moorings Marina with numerous storage buildings and asphalt covered areas for boat storage. The site is bordered to the north by Dutchman's Cove Marina and Boat Rentals; to the east by Fox Street and a residential subdivision; to the south by residential buildings; and to the west by Penetang Harbour. The site generally slopes down from east to west approximately 4.5 m between borehole locations.

The purpose of this geotechnical investigation is to determine the soil and groundwater conditions in the area of the proposed residential development and provide geotechnical engineering recommendations for site grading, site servicing, foundations, concrete slab-on-grade, pavement design, subdrainage requirements, and stormwater infiltration.

2.0 CONCURRENT WORK

MTE conducted a due diligence Phase 2 ESA on October 16, 2017, File No. 43022-100, and is currently conducting a Phase 2 ESA and Record of Site Condition environmental investigation at the site. Environmental technicians were onsite directing the drilling and sampling during the fieldwork.

3.0 FIELD AND LABORATORY PROGRAM

The fieldwork for this investigation was carried out on March 26th, April 9th and April 10th, 2018 and involved the drilling of twenty boreholes (Boreholes BH201-18 to BH220-18) to depths ranging from 1.5 to 8.2 m. The locations of the boreholes are shown on the Site Plan, **Figure 2 in Appendix A**.

Private and public utility companies were contacted prior to the start of drilling activities in order to isolate underground utilities near the boring locations.

The boreholes were advanced with a Geoprobe 7822DT track mounted drill rig equipped with continuous flight hollow stem augers and direct push equipment, supplied and operated by Direct Environmental Drilling Inc.

Boreholes MW202-18 and BH216-18 to BH220-18 were advanced with hollow stem augers for geotechnical data and sample collection, while Boreholes BH201-18 and MW203-18 to BH215-18 were advanced using direct push equipment for environmental sample collection.

Representative soil samples were recovered throughout the depths explored. Standard Penetration Tests (SPT) were carried out during sampling operations in Boreholes MW202-18 and BH216-18 to BH220-18 using conventional split spoon equipment. The SPT N-values recorded are plotted on the borehole logs in **Appendix B**.

Samples of the cohesive soil samples were tested using a pocket penetrometer, in Boreholes MW202-18 and BH216-18 to BH220-18, respectively, to determine approximate shear strengths. The results of the penetrometer testing are plotted on the appended borehole logs.

A 50 mm diameter monitoring well and a 19 mm diameter monitoring well were installed in Boreholes MW202-18 and MW203-18 to allow measurement of the stabilized groundwater levels and groundwater sampling and testing. The installation comprised of a 3.0 m filtered screen and a bentonite seal above the screen. Details of the installation and groundwater observations and measurements are provided on the appended borehole logs.

The monitoring wells were installed in accordance to Ontario Regulation 903, as amended. A licensed well technician must properly decommission all wells before construction. The construction, maintenance and abandonment of the wells are regulated under the province's Water Resources Act.

Upon completion of drilling, the boreholes were backfilled with soil cuttings and bentonite in accordance with Ontario Regulation 468/10 (formerly O. Reg. 903) under the provinces Water Resources Act.

The fieldwork was monitored throughout by members of our geotechnical and environmental engineering staff, who directed the drilling procedures; conducted SPT tests; documented the soil stratigraphies; monitored the groundwater conditions; installed the monitoring wells; and transported the recovered soil samples back to our office for further classification.

The ground surface elevations at the borehole locations were surveyed by MTE by use of a Trimble survey device and tied into geodetic elevations.

Soil samples collected were submitted for moisture content testing. Geotechnical laboratory testing comprised of five soil samples submitted for particle size distribution analyses, one soil sample for grain size distribution analysis, and two samples for Atterberg Limits tests. The results of the laboratory tests are provided in **Appendix C**. The remaining soil samples will be stored for a period of 1 month and will be discarded of at that time without prior request from the client to extend storage time.

4.0 SOIL CONDITIONS

Reference is provided to the appended borehole logs for soil stratigraphy details, SPT N-values, results of pocket penetrometer testing, moisture content profiles, and groundwater observations and measurements. Soil conditions encountered at the site typically include asphaltic concrete and/or fill overlying native sand, silt, and clay deposits.

4.1 Asphaltic Concrete and Fill

Three of the boreholes (Boreholes MW202-18, BH216-18 and BH218-18) were drilled within the existing parking and driveway areas and encountered 50 to 100 mm of asphaltic concrete overlying fill.

Fill was encountered surficially or beneath the asphaltic concrete in all of the boreholes and is 0.1 to 4.0 m thick (average thickness = 1.9 m). The fill ranges in composition from brown silty sand and gravel to grey clayey silt. It is noted organics (topsoil) was contacted within the fill at Boreholes BH205-18, BH206-18, BH209-18, BH210-18, BH211-18, BH212-18, BH217-18, BH219-18 and BH220-18 and organic content (rootlets, peat and wood fragments) were contacted within the fill in all of the boreholes except Boreholes BH201-18, BH204-18, BH207-18 and BH216-18. Brick fragments, Styrofoam pieces and large cobbles were contacted in Boreholes BH219-18, BH207-18 and BH216-18, respectively. SPT N-values in the fill range from 1 to 46 blows per 300 mm penetration of the split spoon sampler indicating a very loose to dense relative density.

In situ moisture contents in the fill range from 5 to 40% indicating moist to saturated conditions.

4.2 Silt / Silt and Clay

Silt was encountered underlying the fill and/or sand in Boreholes BH201-18, MW202-18, MW203-18, BH204-18, BH210-18, BH212-18, BH213-18, BH215-18, BH218-18, BH219-18 and BH220-18. The silt and clay was 0.6 to 2.3 m thick and continues to the termination depth of Boreholes BH201-18, BH210-18, BH212-18 and BH213-18. The silt ranges in composition from brown sandy silt to grey clay and silt with trace sand. The results of three particle size distribution analyses conducted on samples of the silt and clay are provided in **Appendix C** and summarized in the following table;

TABLE 1 - RESULTS OF SILT AND CLAY PARTICLE SIZE DISTRIBUTION ANALYSES

Borehole Number	Sample Depth (m)	Sand (%)	Silt (%)	Clay (%)
MW202-18	3.05-3.66	1	52	47
BH218-18	2.29-2.90	29	66	5
BH219-18	1.52-2.13	5	44	51

The SPT N-values in the silt range from 0 to 6 blows per 300 mm penetration of the split spoon sampler indicating a very loose to loose relative density. Shear strength measured in the cohesive deposits of the silt and clay ranges from was 25 to 100 kPa using a pocket penetrometer.

Two samples of the silt and clay were submitted for Atterberg Limits tests and the results summarized in the following table;

TABLE 2 - RESULTS OF SILT AND CLAY ATTERBERG LIMITS TESTS

Borehole Number	Sample Depth (m)	Moisture Content (%)	Liquid Limit (LL)	Plastic Limit (PL)	Plasticity Index (PI)	Liquidity Index (LI)
MW202-18	1.52-2.13	21	25	14	11	0.63
BH219-18	1.52-2.13	40	47	22	25	-0.28

Atterberg limits test results indicate the silt and clay has a medium degree of plasticity.

Insitu moisture contents in the silt range from 21 to 40% indicating wet to saturated or drier than the plastic limit (DTPL) to wetter than the plastic limit (WTPL) conditions.

4.3 Sand

Sand was encountered beneath the fill and/or silt and clay in all of the boreholes except for Boreholes BH210-18 and BH212-18. The sand was 0.9 m and 0.6 m thick in Boreholes BH201-18 and BH213-18, respectively. The sand continues to the termination depth in the remaining boreholes. The sand deposit was underlain by a silt and clay layer in Boreholes MW202-18 and BH204-18 at a depth of 1.5 m (Elevation 176.4 m) and 0.6 m (Elevation 178.8 m), and then continues again at a depth of 3.8 m (Elevation 174.1 m) and 0.9 m (Elevation 178.5 m) to the termination depth of each borehole. The sand typically ranges in composition from grey gravelly sand with some silt to brown silty sand with trace clay. The results of three grain/particle size distribution analyses conducted on the sand are provided in **Appendix C** and summarized in the following table;

TABLE 3 - RESULTS OF SAND PARTICLE/GRAIN SIZE DISTRIBUTION ANALYSES

Borehole Number	Sample Depth (m)	Gravel (%)	Sand (%)	Silt (%)	Clay (%)
BH217-18	1.52-2.13	0	74	25	1
BH220-18	3.05-3.66	8	62	24	6
BH216-18	4.57-5.18	0	98	2	

SPT N-values measured in the sand typical increase with depth and range from 0 to 23 blows per 300 mm penetration of the split spoon sampler indicating very loose to compact conditions.

In situ moisture contents in the sand range from 6 to 30% indicating moist to saturated conditions.

5.0 GROUNDWATER CONDITIONS

Groundwater observations and measurements were carried out in the open boreholes at the time of drilling and are summarized on the borehole logs. Upon completion of drilling activities, free groundwater was encountered in all of the geotechnical boreholes and the depths and elevations are summarized in the following table;

TABLE 4 - GROUNDWATER DEPTHS AND ELEVATIONS UPON COMPLETION OF DRILLING

Borehole Number	Borehole Elevation (m)	Groundwater Depth (m)	Groundwater Elevation (m)
MW202-18	177.87	0.31	177.56
BH216-18	182.24	2.90	179.34
BH217-18	178.11	1.22	176.89
BH218-18	178.11	0.91	177.20
BH219-18	179.97	1.52	178.45
BH220-18	178.82	1.22	177.60

It should be noted that the groundwater levels can vary and are subject to seasonal fluctuations and local variations. Additional groundwater levels will be measured in the installed wells prior to finalization of the report.

6.0 DISCUSSION AND RECOMMENDATIONS

6.1 General

The project involves the design of a new residential development which will include 60 units total with 28 single detached residential buildings, 6 semi-detached residential buildings and 26 townhomes. The site is currently the Bay Moorings Marina located along Fox Street in Penetanguishene, Ontario. Three new roadways are proposed within the development.

The subsurface stratigraphy at the site comprises asphaltic concrete and/or fill overlying native sand, silt, and clay deposits. Free groundwater was encountered at Elevation 176.89 to 179.34 m upon completion of drilling activities.

Based on the results of this geotechnical investigation, the site is suitable for the proposed development; however the fill thickness, the low strength of the native soils and the high groundwater table will affect design and construction. The following subsections of this report contain geotechnical recommendations pertaining to development of the property including site grading, site servicing, foundations, floor slabs, pavement design, subdrainage requirements, and stormwater infiltration.

6.2 Site Preparation

The first construction activity that will be required for the proposed development will be grading. Due to the volume of fill at the site (average thickness = 1.9 m) and loose native soil deposits, It is understood leaving the existing fill in place is the preferred option. The residential units will need to be properly supported with deep foundations and roadways properly supported with geogrids and geotextiles.

The surficial organic topsoil would not be suitable to remain below the residential units and roadways and must be removed. The topsoil could be used in landscaping areas such as parks, pending consultation with environmental engineers.

These recommendations are subject to change if additional soil is to be removed as part of site remediation activities. The extent of the site remediation was unknown at the time of this report.

The native soils are not suitable for reuse as engineered fill due to high moisture contents. All engineered fill should be imported and placed in maximum 300 mm thick lifts, compacted to the following percentages;

TABLE 5 - ENGINEERED FILL REQUIREMENTS

Fill Use	Minimum Compaction Required
Structural fill to support structures	100% SPMDD
Subgrade fill beneath pavements or services	95% SPMDD
Bulk fill in landscape areas	90% SPMDD

Structural fill used for raising grades beneath the residential units should be comprised of granular material such as OPSS Granular 'A'. Subgrade fill material beneath the proposed pavement areas and services should meet the requirements of OPSS Select Subgrade Material. Any imported fill should be tested and verified by a geotechnical engineer prior to placement.

Structural fill pads should extend a minimum 0.3 m beyond the edge of the footing envelope of any building and down to subgrade at an angle of 45 degrees to the horizontal. Full time testing by geotechnical personnel is recommended during fill placement and compaction to monitor material quality, lift thickness, and verify the compaction by insitu density testing.

In order to minimize the effects of weather and groundwater, fill operations onsite should be carried out in the dry summer months.

6.3 Site Servicing

6.3.1 Excavations and Dewatering

The development will be serviced to provide the individual lots with full municipal services. It is anticipated that the invert levels for watermain and sanitary sewers will be at conventional depths.

Temporary excavations to conventional depths for installation of underground pipes at this site must comply with the Ontario Occupational Health and Safety Act and Regulations for Construction Projects. The fill would be classified as Type 4 soils and temporary side slopes must be trimmed back at an inclination of 3 horizontal to 1 vertical or less above the base of the trench as per O.Reg 213/91. The native soils encountered in the boreholes would be classified as Type 3 soils (O. Reg. 213/91, s. 226 (4)). Temporary side slopes must be cut at an inclination of 1.0 horizontal to 1.0 vertical or less from the base of the excavation for open cut pipe installation, exclusive of groundwater effects.

Trench side slopes must be continuously inspected, especially after periods of heavy rainfall or snow melt to identify areas of instability. Surface water should be directed away from entering the trench.

Moderate to high groundwater inflow should be expected where the excavations extend into the groundwater table encountered within the fill and native sand deposits. It is envisioned that groundwater inflow from the excavations extending up to 0.3 m below the groundwater regime can be controlled using a gravity dewatering system with properly constructed sumps and perimeter interceptor ditches and pumps. Well points or an equivalent system may be required for any excavation work extending more than 0.3 m below the groundwater regime.

It should be noted that a Permit to Take Water (PTTW), issued by the Ministry of Environment and Climate Change (MOECC), will be required if the dewatering system/sumps result in water taking of more than 50,000 L/day. The design of the dewatering system should be left to the contractor's discretion to control groundwater at least 0.5 m below the invert level in order to provide stable excavation base.

It is recommended that test pits be excavated during the tendering stage of the project to familiarize potential contractors of the soil and groundwater conditions at the site.

6.3.2 Pipe Bedding

It is anticipated invert elevation of the pipes will be at conventional 2 to 3 m depths below ground surface. The existing loose fill and organic soils contacted at the site are not suitable to support pipes without undergoing possible detrimental post-construction settlement. The fill and organic soil should be subexcavated from below the pipes and replaced with well-compacted granular soil, or the pipes should be constructed in structurally supported pipe conduits.

For non-critical flexible piping, the existing fill and organic soils may remain in place below the pipe invert provided that it is understood that some long-term settlement may occur.

Pipe bedding for water and sewer services should be conventional Class 'B' pipe bedding comprising a minimum 150 mm thick layer of OPSS Granular 'A' aggregate below the pipe invert. Granular 'A' type aggregate should be provided around the pipe to at least 300 mm above the pipe and the bedding aggregate should be compacted to a minimum 95% standard Proctor maximum dry density (SPMDD).

A well-graded clear stone such as Coarse Aggregate for HL4 Asphaltic Concrete (OPSS 1003) could be used in the sewer trenches as bedding below the spring line of the pipe to facilitate sump pump dewatering, if necessary. The clear stone should be compacted with a plate tamper

6.3.3 Groundwater Cutoffs

The proposed alignment of the sewers could create a hydraulic connection between groundwater regimes that are not currently connected. To prevent the movement of water along the pipe bedding, it is recommended that concrete or clay cutoff collars be installed. The cutoffs should be 1 m long and in place of regular bedding material.

6.3.4 Trench Backfilling

The trenches above the specified pipe bedding should be backfilled with engineered fill placed in 300 mm thick lifts and compacted to at least 95% SPMDD. Wet or saturated native mineral soils are not considered suitable for reuse as trench backfill. Any additional material required at the site should comprise imported granular soils such as OPSS Select Subgrade Material.

To minimize potential problems, backfilling operations should follow closely after excavation so that only a minimal length of trench is exposed. Care should be taken to protect side slopes of excavations by diverting surface run-off away from the excavations. If construction extends into the winter, then additional steps should be taken to minimize frost and ensure that frozen material is not used as backfill.

6.3.5 Manholes

The geotechnical bearing resistance at manhole locations should be analyzed for potential settlement prior to final design. Precast concrete manholes shall be backfilled with compacted Type 1 Granular 'B' material on all sides for ease of compaction and to minimize post-construction settlement. The backfill should be placed in maximum 500 mm thick lifts and brought up evenly on all sides in order to provide uniform lateral support and earth pressure. All precast manhole bases shall be set on a pad of drainage stone or Granular 'A' with a minimum thickness of 150 mm.

It is recommended that MTE review the final sewer invert and manhole elevations during design to confirm that the recommendations provided are sufficient for the proposed works.

6.4 Pavements

It is understood pavements will be constructed for the new roadways and parking areas at the site. MTE recommends that the roadways be supported with geogrids and geotextiles due to the existing fill.

A 270R Non-Woven Geotextile provided by Terrafix Geosynthetics Inc. in conjunction with a TX140 Geogrid supplied by Tensar International Corporation, or approved equivalent, is recommended to be placed on the subgrade to provide adequate material separation and strength for the pavement design. Final pavement design should be verified once design details are known. Tensar International Corporation product design information is provided in **Appendix D**.

The pavement component thicknesses in the following table are recommended based on the proposed pavement usage, the frost-susceptibility and strength of the subgrade soils, and the Tensar International Corporation SPECTRAPAVE4-PRO software;

TABLE 6 - PAVEMENT DESIGN

Pavement Component	Local Residential Street And Parking Areas
Asphalt Hot Mix	90 mm
OPSS 1010 Granular 'A' Base	150 mm
OPSS 1010 Granular 'B' Subbase	300 mm

The geogrids and geotextiles must be designed and installed by licensed service providers. The installation process must be inspected by a geotechnical engineer.

Samples of aggregates should be checked for conformance to OPSS 1010 prior to utilization on site and during construction. The Granular 'B' subbase and Granular 'A' base courses must be compacted to 100% SPMDD, as verified by insitu density testing.

The asphaltic concrete paving materials should conform to the requirements of OPSS 1150. The asphalt should be placed and compacted in accordance with OPSS 310. The Performance Graded Asphalt Cement designation for the asphaltic concrete is 58-28.

The asphaltic concrete should comprise 40 mm of HL4 surface over 50 mm of HL8 binder for local residential streets.

The pavement design is based on the assumption that construction will be carried out during the drier time of the year and that the subgrade soil is stable and geogrid and geotextile installation inspection by a geotechnical engineer. If the subgrade is wet and unstable, additional granular subbase will be required.

All materials and construction services required for the work should be in accordance with the relevant sections of the Ontario Provincial Standard Specifications.

It is recommended to install subdrains beneath the low areas of pavement and connected to catchbasins. The purpose of the subdrains is to remove excess subsurface water in order to improve overall pavement serviceability and increase the pavement life. Consideration should be given to providing continuous subdrains along the perimeter edges of the new street to promote drainage of the granular materials.

The work of subdrain installation shall be in accordance with OPSS 405 and OPSD 216.021. The subdrain shall be 100 or 150 mm diameter perforated pipe conforming to OPSS 1801 or 1840, and wrapped with geotextile conforming to OPSS 1860.

6.5 Curbs, Gutter and Sidewalks

The concrete for curbs, gutters and sidewalks should be proportioned, mixed, placed and cured in accordance with the requirements of OPSS 353, and OPSS 1350 and shall meet the following specific requirements (OPSS 353.05.01):

- Minimum compressive strength = 30 MPa at 28 days
- Coarse aggregate = 19.0 mm nominal max. size
- Maximum slump = 60 mm for curb and gutter, 70 mm for sidewalk
- Air entrainment = $7.0 \pm 1.5\%$

During cold weather any freshly placed concrete must be covered with insulating blankets to protect against freezing as per OPSS 904. Three cylinders from each days pour should be taken for compressive strength testing. Air entrainment, temperature and slump tests should be conducted on the same batch of concrete from the test cylinders made.

6.6 Residential Foundation Design

Considering the presence of fill and soft silt and clay stratum at deeper depths and associated significant consolidation settlements due to structural loads, it is recommended that the foundations for the proposed residential units be placed on helical piles.

A helical pier foundation system comprises medium diameter steel helices on the end of small diameter solid steel shafts. The steel helices are screwed into the ground to the level of competent bearing soil and attached to grade beams to support the residential units. A pull-down grout system should be used in order to encase the shaft and to provide additional support, lifting resistance and longevity of the foundation system

The piles would be drilled through the existing fill and loose native soils and into the compact native soils encountered approximately at a depth of 9.1 m. Chance SS5 Helical Pile with a compression capacity of 200 kN at Serviceability Limit States (SLS) and 270 kN at Ultimate Limit States (ULS) supplied by EBS Geostructural Inc. or approved equivalent would be adequate to support the residential units. Design dimensions and a product information are provided in **Appendix E**.

The individual pier loading should be confirmed by the contractor supplying and installing the helical piers and by load tests (larger diameter helices could support higher loads). The center-to-center spacing of piles should be at least three times the helix diameter. The pile stability, pile head and pile cap details should be determined and checked by an experienced Structural Engineer and reviewed by the Geotechnical Consultant.

The helical pier installation operations should be monitored on a full-time basis by qualified geotechnical personnel to check, foundation elevation, and allowable pier loading through torque testing.

The helical piles must be designed and installed by licensed service providers. The installation process must be inspected by a geotechnical engineer.

The grade beams between the helical piers must be provided with a minimum 1.2 m of earth cover after final grading in order to minimize the potential of damage due to frost action. If construction is undertaken during the winter, the subgrade soil and concrete should be protected from freezing.

All excavations at the site should be carried out in conformance with the Ontario Occupational Health and Safety Act and Regulations for Construction Projects. The fill would be classified as Type 4 soils and temporary side slopes must be trimmed back at an inclination of 3 horizontal to 1 vertical or less above the base of the trench as per O.Reg 213/91 s.234(2). The trench side slopes must be cut back at a shallower angle where waterbearing deposits are encountered.

6.7 Concrete Slab-on-Grade Floors

It is recommended the floor slabs be designed as structural slabs due to the low strength of the fill onsite. MTE does not recommend the construction of basements due to the low strength of native soils and high groundwater table at the site.

No significant methane gas headspace readings were recorded in the fill. Please refer to MTE's due diligence Phase 2 ESA conducted on October 16, 2017, File No.43022-100, for the results of the methane gas headspace readings.

Any additional material required to raise grades below the floor slabs should be comprised of sand and gravel and be compacted to 100% SPMDD. A minimum 150 mm thick layer of Granular 'A' material uniformly compacted to 100% SPMDD should be provided directly beneath the slab for leveling and support purposes.

No special underfloor drains are required, provided the exterior grades are lower than the floor slab and positively sloped away from the building.

The water to cement ratio and slump of the concrete utilized in the floor slab should be strictly controlled to minimize shrinkage of the slab. Control joints should be sawed into the slabs at regular intervals within 12 hours of initial concrete placement in order to pre-locate shrinkage cracks.

Concrete testing should be performed onsite to determine the slump, temperature, and air entrainment; and concrete cylinders should be cast for compressive strength testing.

6.8 Stormwater Infiltration

It is understood that at-source infiltration of stormwater runoff from the development may be considered for this site. Soak-away pits generally require native soils with a minimum percolation rate of 15 mm/hr and a minimum separation between the bottom of the pit and the seasonally high water table of 1 m (MOE, 2003).

Due to the high groundwater table, at approximately Elevation 176.89 to 179.34 m, and the large amount of fill materials at the site, at-source infiltration of stormwater runoff is not geotechnically feasible for the development.

7.0 LIMITATIONS OF REPORT

Services performed by **MTE Consultants Inc.** (MTE) were conducted in a manner consistent with the level of care and skill ordinarily exercised by members of the Geotechnical Engineering & Consulting profession practicing under similar conditions in the same geographic area where the services are provided. No other warranty or representation expressed or implied as to the accuracy of the information, conclusions or recommendations is included or intended in this report.

This report was completed for the sole use of the Client. This report is not intended to be exhaustive in scope or to imply a risk-free site. As such, this report may not deal with all issues potentially applicable to the site and may omit aspects which are or may be of interest to the reader.

In addition, it should be recognized that a soil sample result represents one distinct portion of a site at the time it is collected, and that the findings of this report are based on conditions as they existed during the time period of the investigation. The material in the report reflects our best judgment using the information available at the time the report was written. The soil and groundwater conditions between and beyond the test holes may differ from those encountered in the test holes. Should subsurface conditions arise that are different from those in the test holes MTE should be notified to determine whether or not changes should be made as a result of these conditions.

It should be recognized that the passage of time may affect the views, conclusions and recommendations (if any) provided in this report because groundwater conditions of a property can change, along with regulatory requirements. All design details were not known at the time of submission of this report and it is recommended MTE should be retained to review the final design documents prior to construction to confirm they are consistent with our report recommendations. Should additional or new information become available, MTE recommends that it be brought to our attention in order that we may determine whether it affects the contents of this report.

Any use which another party makes of this report, or any reliance on, or decisions to be made based upon it, are the responsibility of such parties. MTE accepts no responsibility for liabilities incurred by or damages, if any, suffered by another party as a result of decisions made or actions taken, based upon this report. Others with interest in the site should undertake their own investigations and studies to determine how or if the condition affects them or their plans. The contractors bidding on this project or undertaking the construction should make their own interpretation of the factual information and draw their own conclusions as to how subsurface conditions may affect their work.

The benchmark and elevations provided in this report are primarily established to identify differences between the test hole locations and should not be used for other purposes such as, planning, development, grading, and excavation.

Respectfully submitted,

MTE CONSULTANTS INC.



Ben Heinbuch, EIT
Senior Geotechnical Technician

MXW:dld



Montana Wilson, M.Eng. P.Eng. PMP
Civil and Geotechnical Division Manager





APPENDIX A

FIGURES

Figure 1- Location Plan
Figure 2 - Site Plan



ARIEL IMAGE FROM GOOGLE EARTH



LOCATION PLAN

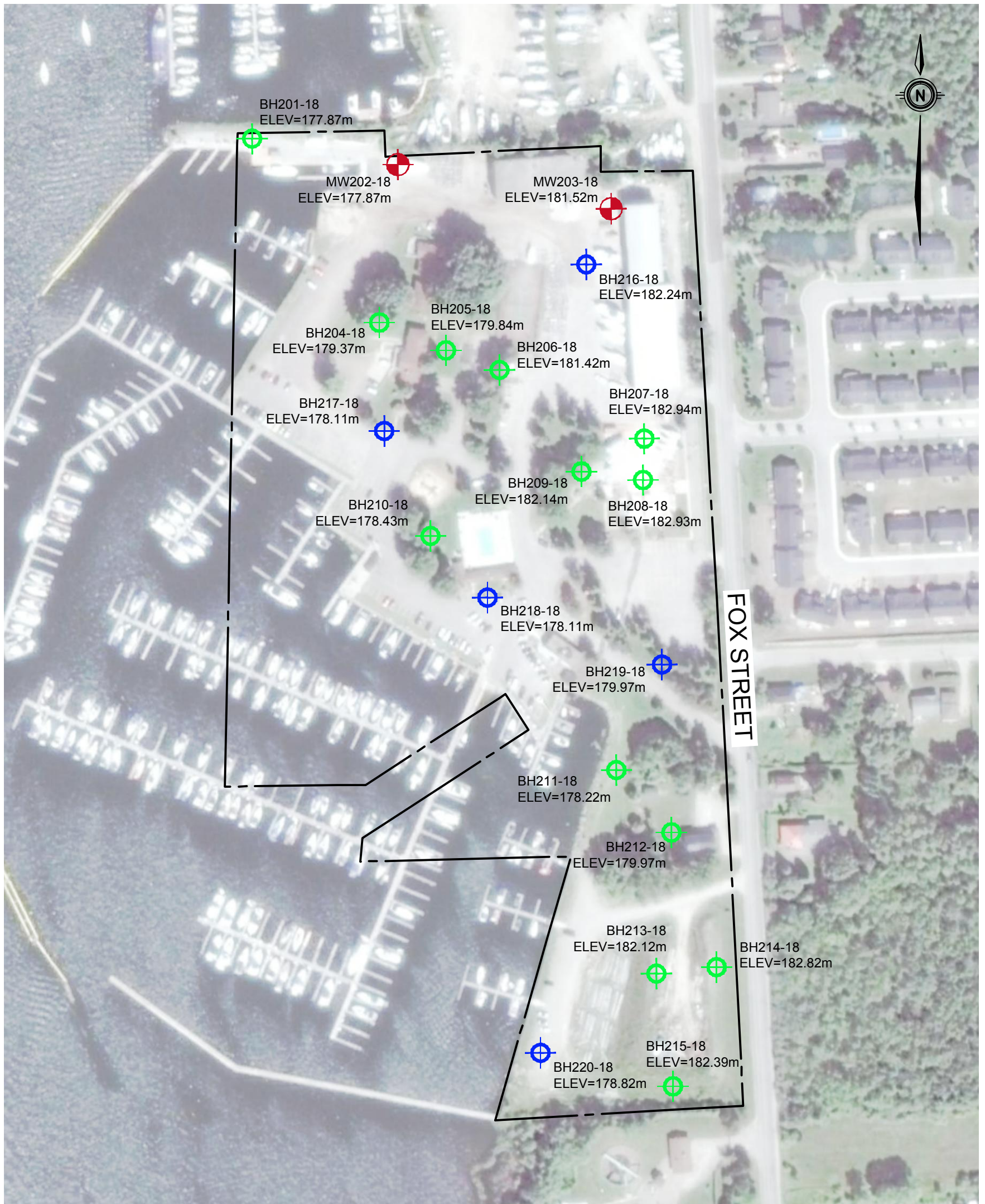

<i>Project Name</i>			
FOX STREET PENETANGUISHENE SUBDIVISION			
<i>Site</i>		<i>Client</i>	
160 - 200 FOX STREET, PENETANGUISHENE, ONTARIO		WILMINGTON CAPITAL MANAGEMENT INC.	
<i>Scale: (8.5x11)</i>	<i>MTE Project No.</i>	<i>Date</i>	<i>Figure No.</i>
N.T.S	43022-100	MAY.01.2018	1



LEGEND

-  BH201-18
DIRECT PUSH METHOD BOREHOLE
-  BH216-18
HOLLOW STEM AUGERS BOREHOLE
-  MW202-18
MONITORING WELL

REFERENCES:

- ARIEL IMAGE FROM GOOGLE EARTH
 - THE GROUND SURFACE ELEVATIONS AT THE BOREHOLE LOCATIONS WERE SURVEYED BY MTE BY THE USE OF A TRIMBLE SURVEY DEVICE AND TIED INTO GEODETIC ELEVATIONS.

SITE PLAN



<i>Project Name</i> FOX STREET PENETANGUISHENE SUBDIVISION			
<i>Site</i> 160 - 200 FOX STREET, PENETANGUISHENE, ONTARIO		<i>Client</i> WILMINGTON CAPITAL MANAGEMENT INC.	
<i>Scale (11x17)</i> 1:2000	<i>MTE Project No.</i> 43022-100	<i>Date</i> MAY.01.2018	<i>Figure No.</i> 2



APPENDIX B

BOREHOLE LOGS

Boreholes BH201-18
to BH220-18

ID Number: BH201-18

Project: Fox Street, Penetanguishene Development

Project No: 43022-100

Client: Wilmington Capital Management Inc.

Site Location: 160 - 200 Fox Street, Penetanguishene, ON

Drill Date: 3/26/2018

Drilling Contractor: Direct Environmental Drilling

Drill Rig: Geoprobe 7822DT

Drill Method: Direct Push

Protective Cover: N/A

SUBSURFACE PROFILE			SAMPLE				HEADSPACE	Well Completion Details
Depth	Symbol	Soil Description	Elevation (masl) Depth (m)	Number	Type	Recovery (%)	Soil Sample Lab Analysis	
0		Ground Surface	177.9					
0		FILL brown silty sand and gravel, trace brick fragments, very moist	177.6					
0.3		fine sand, some silt, wet	176.7					
2			176.4					
4		silty sand, saturated	176.4					
6		SAND light brown, medium coarse sand, some silt, saturated	175.4					
8			175.4					
8		SILT AND CLAY light grey sandy silt and clay, DTPL	174.8					
10		Drilling Terminated	174.8					
10			3.0					

HEADSPACE	
VOC ppm	20 40 60 80
Hydrocarbon ppm	100 200 300 400

Field Technician: K. Maddock

Drafted by: S. Rederer

Reviewed by: R. Fedy



ID Number: MW202-18

Project: Fox Street, Penetanguishene Development

Project No: 43022-100

Client: Wilmington Capital Management Inc.

Site Location: 160 - 200 Fox Street, Penetanguishene, ON

Drill Date: 3/26/2018

Drilling Contractor: Direct Environmental Drilling

Drill Rig: Geoprobe 7822DT

Drill Method: Hollow Stem Augers

Protective Cover: N/A

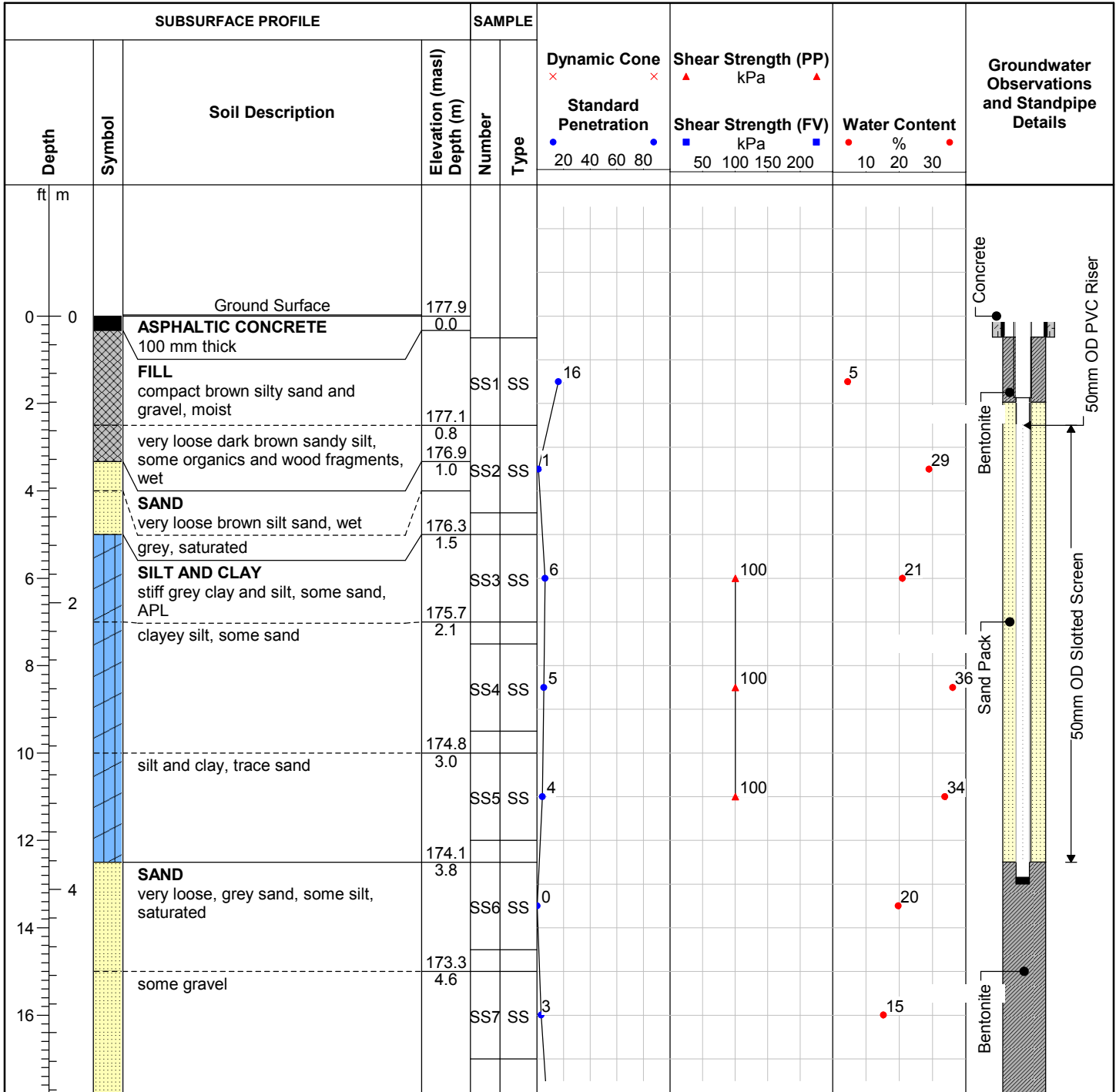

Field Technician: M. Dalglish

Drafted by: B. Heinbuch

Reviewed by: M. Wilson



ID Number: MW202-18

Project: Fox Street, Penetanguishene Development

Project No: 43022-100

Client: Wilmington Capital Management Inc.

Site Location: 160 - 200 Fox Street, Penetanguishene, ON

Drill Date: 3/26/2018

Drilling Contractor: Direct Environmental Drilling

Drill Rig: Geoprobe 7822DT

Drill Method: Hollow Stem Augers

Protective Cover: N/A

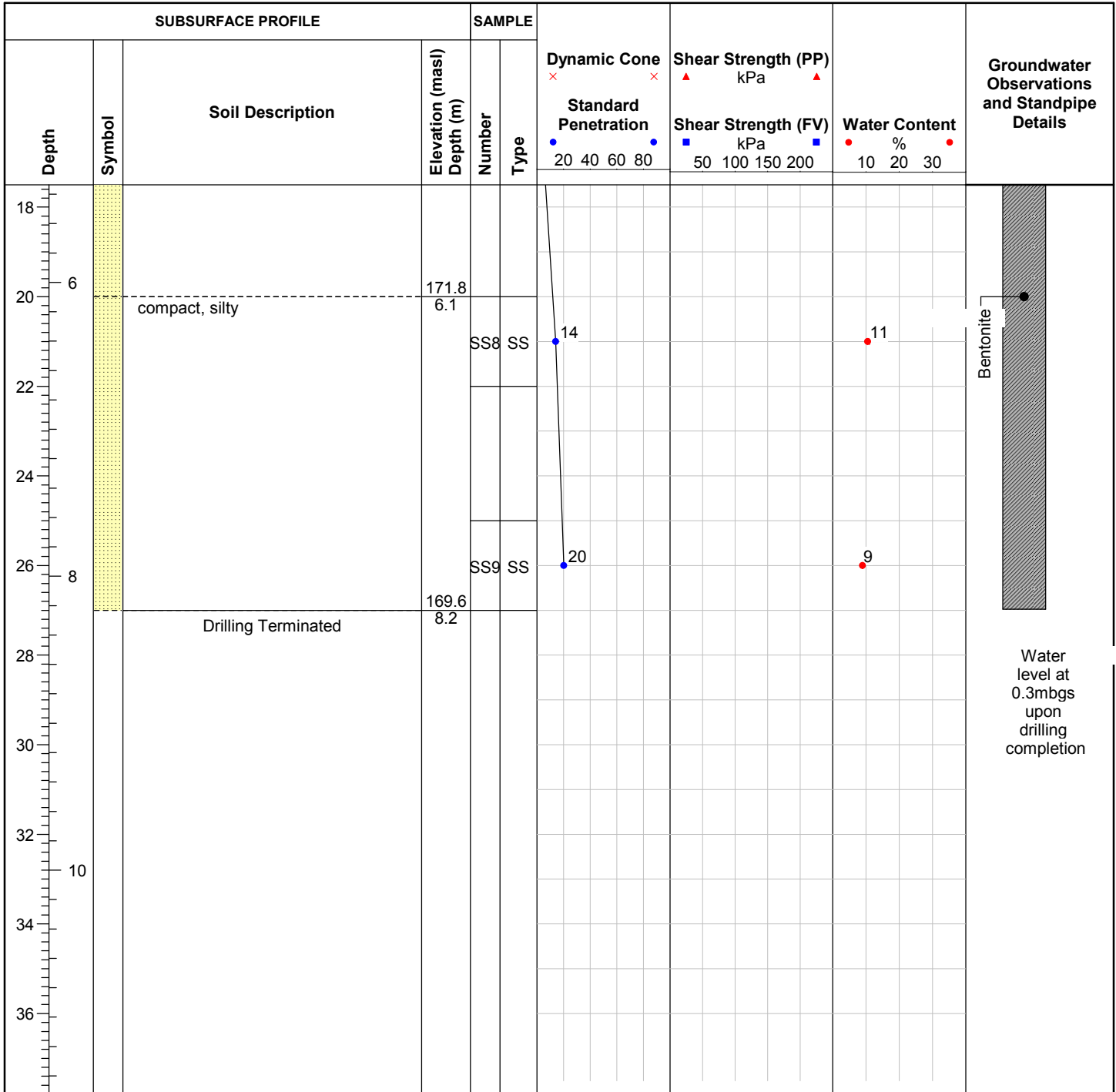

Field Technician: M. Dalgliesh

Drafted by: B. Heinbuch

Reviewed by: M. Wilson



ID Number: MW203-18

Project: Fox Street, Penetanguishene Development

Project No: 43022-100

Client: Wilmington Capital Management Inc.

Site Location: 160 - 200 Fox Street, Penetanguishene, ON

Drill Date: 4/9/2018

Drilling Contractor: Direct Environmental Drilling

Drill Rig: Bosch Pionjar

Drill Method: Direct Push

Protective Cover: Monument

SUBSURFACE PROFILE			SAMPLE				HEADSPACE	Well Completion Details				
Depth	Symbol	Soil Description	Elevation (masl) Depth (m)	Number	Type	Recovery (%)	Soil Sample Lab Analysis		VOC ppm			
									20	40	60	80
								Hydrocarbon ppm				
								100	200	300	400	
0		Ground Surface	181.5									
0		FILL brown sand, some silt, trace gravel and organics, moist	0.0									
2												
4		SILT AND CLAY brown clayey silt, some sand trace gravel, DTPL, occasional thin sand seams	180.6	0.9								
6												
8		SAND brown sand trace silt, wet	179.1	2.4								
10		saturated	178.5	3.0								
12		Drilling Terminated	177.9	3.7								
14												
16												

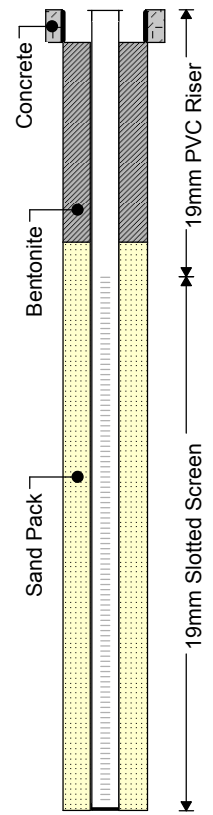

Field Technician: K. Maddock

Drafted by: S. Rederer

Reviewed by: R. Fedy



ID Number: BH204-18

Project: Fox Street, Penetanguishene Development

Project No: 43022-100

Client: Wilmington Capital Management Inc.

Site Location: 160 - 200 Fox Street, Penetanguishene, ON

Drill Date: 4/9/2018

Drilling Contractor: Direct Environmental Drilling

Drill Rig: Geoprobe 7822DT

Drill Method: Direct Push

Protective Cover: N/A

SUBSURFACE PROFILE			SAMPLE				HEADSPACE	Well Completion Details
Depth	Symbol	Soil Description	Elevation (masl) Depth (m)	Number	Type	Recovery (%)	Soil Sample Lab Analysis	
0		Ground Surface	179.4					
0		FILL brown sand, some silt, trace gravel, very moist	0.0					
2		SAND light brown silty sand, wet	178.8					
		SILT light brown silt, some sand, wet	0.6					
		SILT light brown silt, some sand, wet	178.5					
4		SAND brown medium coarse sand and silt, wet	0.9					
		SAND brown medium coarse sand and silt, wet	178.2					
		trace silt	1.2					
		Drilling Terminated	1.5					

Field Technician: K. Maddock

Drafted by: S. Rederer

Reviewed by: R. Fedy



ID Number: BH205-18

Project: Fox Street, Penetanguishene Development

Project No: 43022-100

Client: Wilmington Capital Management Inc.

Site Location: 160 - 200 Fox Street, Penetanguishene, ON

Drill Date: 4/9/2018

Drilling Contractor: Direct Environmental Drilling

Drill Rig: Geoprobe 7822DT

Drill Method: Direct Push

Protective Cover: N/A

SUBSURFACE PROFILE			SAMPLE				HEADSPACE	Well Completion Details
Depth	Symbol	Soil Description	Elevation (masl) Depth (m)	Number	Type	Recovery (%)	Soil Sample Lab Analysis	
0		Ground Surface	179.8					
0		FILL dark brown fine sand and silt, moist	0.0				VOC ppm 20 40 60 80 Hydrocarbon ppm 100 200 300 400	
2		150 mm thick gravel layer, trace brick fragments	179.2					
2		SAND light brown fine sand, some silt, moist	0.6					
6		grey, saturated	178.0					
10		Drilling Terminated	176.8					
10			3.0					
12								
14								
16								

Field Technician: K. Maddock

Drafted by: S. Rederer

Reviewed by: R. Fedy



ID Number: BH206-18

Project: Fox Street, Penetanguishene Development

Project No: 43022-100

Client: Wilmington Capital Management Inc.

Site Location: 160 - 200 Fox Street, Penetanguishene, ON

Drill Date: 4/10/2018

Drilling Contractor: Direct Environmental Drilling

Drill Rig: Geoprobe 7822DT

Drill Method: Direct Push

Protective Cover: N/A

SUBSURFACE PROFILE			SAMPLE				HEADSPACE	Well Completion Details
Depth	Symbol	Soil Description	Elevation (masl) Depth (m)	Number	Type	Recovery (%)	Soil Sample Lab Analysis	
0		Ground Surface	181.4					
0		FILL brown silty sand, trace gravel and clay	0.0					
0.3		sand, some silt, some gravel, trace organics	181.1					
1.2		SAND brown, trace silt, moist	180.2					
1.5		Drilling Terminated	179.9					
2								
4								
6								
8								
10								
12								
14								
16								

Field Technician: K. Maddock

Drafted by: S. Rederer

Reviewed by: R. Fedy



ID Number: BH207-18

Project: Fox Street, Penetanguishene Development

Project No: 43022-100

Client: Wilmington Capital Management Inc.

Site Location: 160 - 200 Fox Street, Penetanguishene

Drill Date: 4/10/2018

Drilling Contractor: Direct Environmental Drilling

Drill Rig: Geoprobe 7822DT

Drill Method: Direct Push

Protective Cover: N/A

SUBSURFACE PROFILE			SAMPLE				HEADSPACE	Well Completion Details
Depth	Symbol	Soil Description	Elevation (masl) Depth (m)	Number	Type	Recovery (%)	Soil Sample Lab Analysis	
0		Ground Surface	182.9					
0		FILL brown sand and gravel, occasional styrofoam pieces, moist some gravel, trace silt, wet	0.0					
2							0	
4								
6								
8								
10			180.2					
10		SAND brown sand, occasional silt layers, wet	2.7				0	
10		Drilling Terminated	179.9					
10			3.0					
12								
14								
16								

Field Technician: K. Maddock

Drafted by: S. Rederer

Reviewed by: R. Fedy



ID Number: BH208-18

Project: Fox Street, Penetanguishene Development

Project No: 43022-100

Client: Wilmington Capital Management Inc.

Site Location: 160 - 200 Fox Street, Penetanguishene, ON

Drill Date: 4/10/2018

Drilling Contractor: Direct Environmental Drilling

Drill Rig: Geoprobe 7822DT

Drill Method: Direct Push

Protective Cover: N/A

SUBSURFACE PROFILE			SAMPLE				HEADSPACE	Well Completion Details
Depth	Symbol	Soil Description	Elevation (masl) Depth (m)	Number	Type	Recovery (%)	Soil Sample Lab Analysis	
0		Ground Surface	182.9					<div style="text-align: center;"> <p>VOC ppm</p> <p>20 40 60 80</p> <p>Hydrocarbon ppm</p> <p>100 200 300 400</p> </div>
0		FILL brown sand, trace silt and gravel, moist	0.0					
2				1	MC			
4								
6								
8								
10		grey silty clay, some wood fragments, very moist, slight odour	180.2	2	MC			
12								
12		SAND brown sand, trace silt, wet	179.3	3	MC			
14								
16								
		Drilling Terminated	178.4					
			4.6					

Field Technician: K. Maddock

Drafted by: S. Rederer

Reviewed by: R. Fedy



ID Number: BH209-18

Project: Fox Street, Penetanguishene Development

Project No: 43022-100

Client: Wilmington Capital Management Inc.

Site Location: 160 - 200 Fox Street, Penetanguishene, ON

Drill Date: 4/10/2018

Drilling Contractor: Direct Environmental Drilling

Drill Rig: Geoprobe 7822DT

Drill Method: Direct Push

Protective Cover: N/A

SUBSURFACE PROFILE			SAMPLE				HEADSPACE	Well Completion Details
Depth	Symbol	Soil Description	Elevation (masl) Depth (m)	Number	Type	Recovery (%)	Soil Sample Lab Analysis	
0		Ground Surface	182.1					
0		FILL dark brown sandy silt, trace clay	0.0					
0.3		grey clayey silt, occasional sand seems, moist	181.8					
0.9		brown sand, trace gravel, silt and organics	181.2					
1.8		SAND brown sand, trace silt, moist	180.3	1	MC			
3.0		Drilling Terminated	179.1	2	MC			
				3	MC			

Field Technician: K. Maddock

Drafted by: S. Rederer

Reviewed by: R. Fedy



ID Number: BH210-18

Project: Fox Street, Penetanguishene Development

Project No: 43022-100

Client: Wilmington Capital Management Inc.

Site Location: 160 - 200 Fox Street, Penetanguishene, ON

Drill Date: 4/9/2018

Drilling Contractor: Direct Environmental Drilling

Drill Rig: Geoprobe 7822DT

Drill Method: Direct Push

Protective Cover: N/A

SUBSURFACE PROFILE			SAMPLE				HEADSPACE	Well Completion Details
Depth	Symbol	Soil Description	Elevation (masl) Depth (m)	Number	Type	Recovery (%)	Soil Sample Lab Analysis	
0		Ground Surface	178.4					
0		FILL dark brown sand, some silt, wet	0.0					
2		gravelly	178.0				Note 1	
2			0.5					
2		PEAT AND ORGANIC SILT dark brown / black sandy silt, some organics, wet	0.7					
4							0	
6			176.6					
6		SILT AND CLAY grey sandy silt, some clay, trace staining	1.9					
8		grey clayey silt, some sand, DTPL	176.2				0	
8			2.2					
10		Drilling Terminated	175.4				0	
10			3.0					
12								
14								
16								



Field Technician: K. Maddock

Drafted by: S. Rederer

Reviewed by: R. Fedy



Notes:
1) PHC: 0, VOC: 1

ID Number: BH211-18

Project: Fox Street, Penetanguishene Development

Project No: 43022-100

Client: Wilmington Capital Management Inc.

Site Location: 160 - 200 Fox Street, Penetanguishene, ON

Drill Date: 4/9/2018

Drilling Contractor: Direct Environmental Drilling

Drill Rig: Geoprobe 7822DT

Drill Method: Direct Push

Protective Cover: N/A

SUBSURFACE PROFILE			SAMPLE				HEADSPACE	Well Completion Details
Depth	Symbol	Soil Description	Elevation (masl) Depth (m)	Number	Type	Recovery (%)	Soil Sample Lab Analysis	
0		Ground Surface	178.2					
0	[Cross-hatched symbol]	FILL brown silt (topsoil), moist	0.0				0	
0.2		brown silty sand and gravel	178.0				0	
2		dark brown/black sandy silt, some organics and topsoil, wet	177.5				0	
2.7	[Dotted symbol]	SAND brown silty sand, saturated	0.7				0	
176.7		Drilling Terminated	1.5					

Field Technician: K. Maddock

Drafted by: S. Rederer

Reviewed by: R. Fedy



ID Number: BH212-18

Project: Fox Street, Penetanguishene Development

Project No: 43022-100

Client: Wilmington Capital Management Inc.

Site Location: 160 - 200 Fox Street, Penetanguishene, ON

Drill Date: 4/9/2018

Drilling Contractor: Direct Environmental Drilling

Drill Rig: Geoprobe 7822DT

Drill Method: Direct Push

Protective Cover: N/A

SUBSURFACE PROFILE			SAMPLE				HEADSPACE	Well Completion Details
Depth	Symbol	Soil Description	Elevation (masl) Depth (m)	Number	Type	Recovery (%)	Soil Sample Lab Analysis	
0		Ground Surface	180.0					
0		FILL brown sandy silt, some gravel and clay, occasional sand seams and topsoil, very moist	0.0				VOC ppm 20 40 60 80 Hydrocarbon ppm 100 200 300 400	
2			179.1				0	
4		dark brown / black sandy silt, some organics, topsoil, rootlets and wood fragments, wet	0.9				0	
4		grey, some gravel, trace clay	1.2				0	
6		SILT AND CLAY light brown silty clay, some sand, trace gravel, WTPL	1.8				0	
10		Drilling Terminated	3.0					
12								
14								
16								

Field Technician: K. Maddock

Drafted by: S. Rederer

Reviewed by: R. Fedy



ID Number: BH213-18

Project: Fox Street, Penetanguishene Development

Project No: 43022-100

Client: Wilmington Capital Management Inc.

Site Location: 160 - 200 Fox Street, Penetanguishene, ON

Drill Date: 4/10/2018

Drilling Contractor: Direct Environmental Drilling

Drill Rig: Geoprobe 7822DT

Drill Method: Direct Push

Protective Cover: N/A

SUBSURFACE PROFILE			SAMPLE				HEADSPACE	Well Completion Details
Depth	Symbol	Soil Description	Elevation (masl) Depth (m)	Number	Type	Recovery (%)	Soil Sample Lab Analysis	
0		Ground Surface	182.1					
0		FILL brown fine sand and silt, some organics, wet	0.0					
2							5	
4								
6		gravelly, some grey clay pockets	180.6	1.5			0	
8								
10								
12		Dark brown / black sandy silt, some organics and topsoil, very moist	178.8	3.4				
12		SAND brown silty sand, wet	178.5	3.7				
14								
14		SILT AND CLAY grey silt and clay, some sand, trace gravel, DTPL	177.9	4.3				
14			177.5	4.6				
16		Drilling Terminated						



Field Technician: K. Maddock

Drafted by: S. Rederer

Reviewed by: R. Fedy



ID Number: BH214-18

Project: Fox Street, Penetanguishene Development

Project No: 43022-100

Client: Wilmington Capital Management Inc.

Site Location: 160 - 200 Fox Street, Penetanguishene, ON

Drill Date: 4/10/2018

Drilling Contractor: Direct Environmental Drilling

Drill Rig: Geoprobe 7822DT

Drill Method: Direct Push

Protective Cover: N/A

SUBSURFACE PROFILE			SAMPLE				HEADSPACE	Well Completion Details
Depth	Symbol	Soil Description	Elevation (masl) Depth (m)	Number	Type	Recovery (%)	Soil Sample Lab Analysis	
0		Ground Surface	182.8					
0		FILL light brown silty sand and gravel, some organics	182.5					
0.3		fine silty sand, very moist	182.5					
2							0	
4			181.3					
1.5		dark brown	181.3					
6								
8			180.4					
2.4		grey, some gravel, trace clay, wet	180.4					
10							0	
12			179.2					
3.7		dark brown / black, gravelly, very moist	179.2					
14			178.9					
4.0		SAND grey sand and silt, trace clay, wet	178.9					
16			178.2					
4.6		Drilling Terminated	178.2					



Field Technician: K. Maddock

Drafted by: S. Rederer

Reviewed by: R. Fedy



ID Number: BH215-18

Project: Fox Street, Penetanguishene Development

Project No: 43022-100

Client: Wilmington Capital Management Inc.

Site Location: 160 - 200 Fox Street, Penetanguishene, ON

Drill Date: 4/10/2018

Drilling Contractor: Direct Environmental Drilling

Drill Rig: Geoprobe 7822DT

Drill Method: Direct Push

Protective Cover: N/A

SUBSURFACE PROFILE			SAMPLE				HEADSPACE	Well Completion Details
Depth	Symbol	Soil Description	Elevation (masl) Depth (m)	Number	Type	Recovery (%)	Soil Sample Lab Analysis	
0		Ground Surface	182.4					
0		FILL brown sand and silt, some gravel, wet	0.0					
2							0	
4								
6		saturated	180.6					
2		grey clayey silt, DTPL	180.3					
8							0	
10								
12		dark brown / black sandy silt, some organics, very moist	179.0					
4		SILT AND CLAY grey clay and silt, some sand, WTPL	178.7					
14		SAND grey fine silty sand, saturated	178.1					
			177.8				0	
		Drilling Terminated	4.6					
16								

Field Technician: K. Maddock

Drafted by: S. Rederer

Reviewed by: R. Fedy



ID Number: BH216-18

Project: Fox Street, Penetanguishene Development

Project No: 43022-100

Client: Wilmington Capital Management Inc.

Site Location: 160 - 200 Fox Street, Penetanguishene, ON

Drill Date: 4/9/2018

Drilling Contractor: Direct Environmental Drilling

Drill Rig: Geoprobe 7822DT

Drill Method: Hollow Stem Augers

Protective Cover: N/A

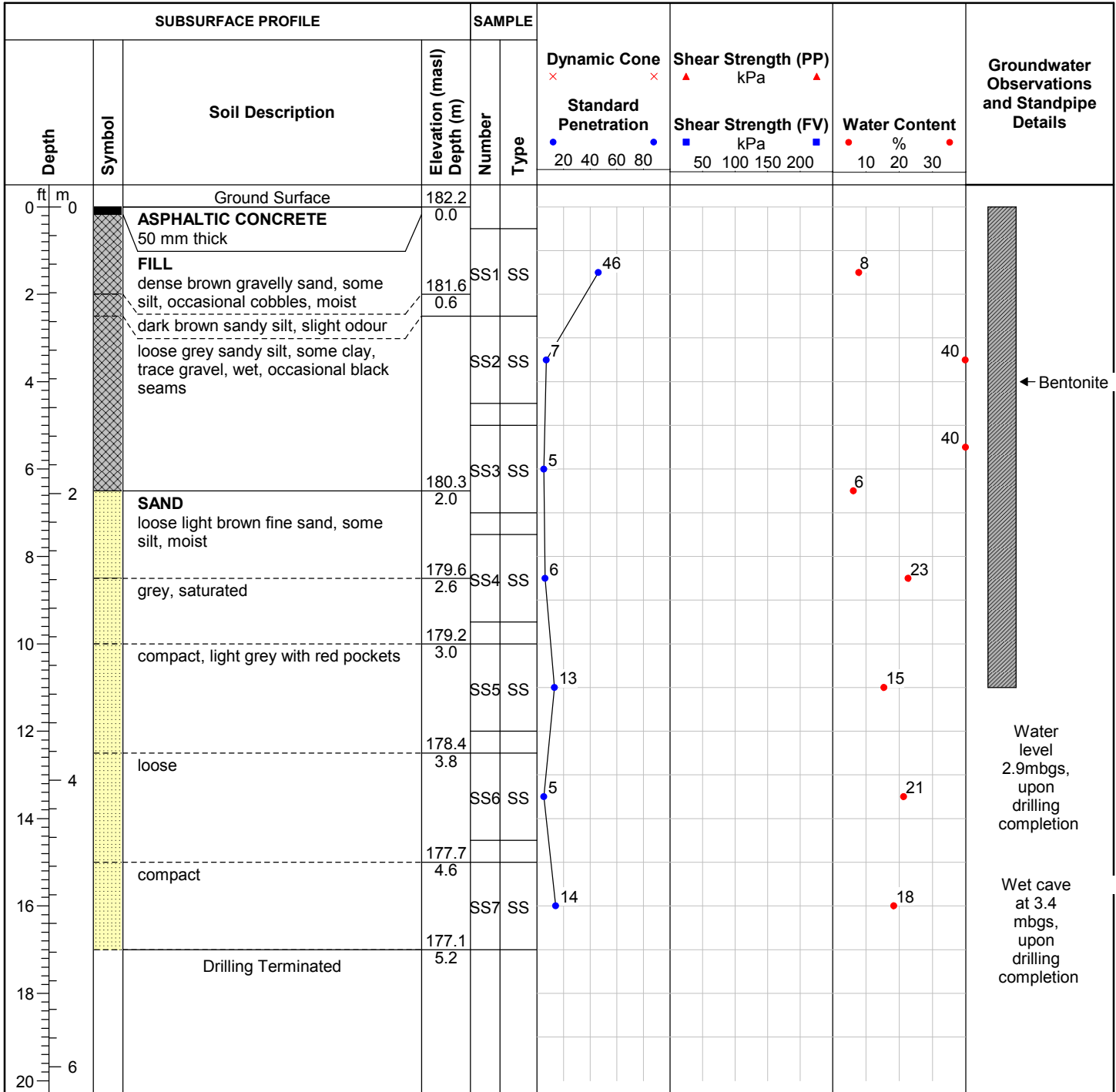

Field Technician: M. Dalglish

Drafted by: B. Heinbuch

Reviewed by: M. Wilson



Notes: Auger refusal on suspected cobble at depth 0.6m, borehole moved 1.5 m west

ID Number: BH217-18

Project: Fox Street, Penetanguishene Development

Project No: 43022-100

Client: Wilmington Capital Management Inc.

Site Location: 160 - 200 Fox Street, Penetanguishene, ON

Drill Date: 4/9/2018

Drilling Contractor: Direct Environmental Drilling

Drill Rig: Geoprobe 7822DT

Drill Method: Hollow Stem Augers

Protective Cover: N/A

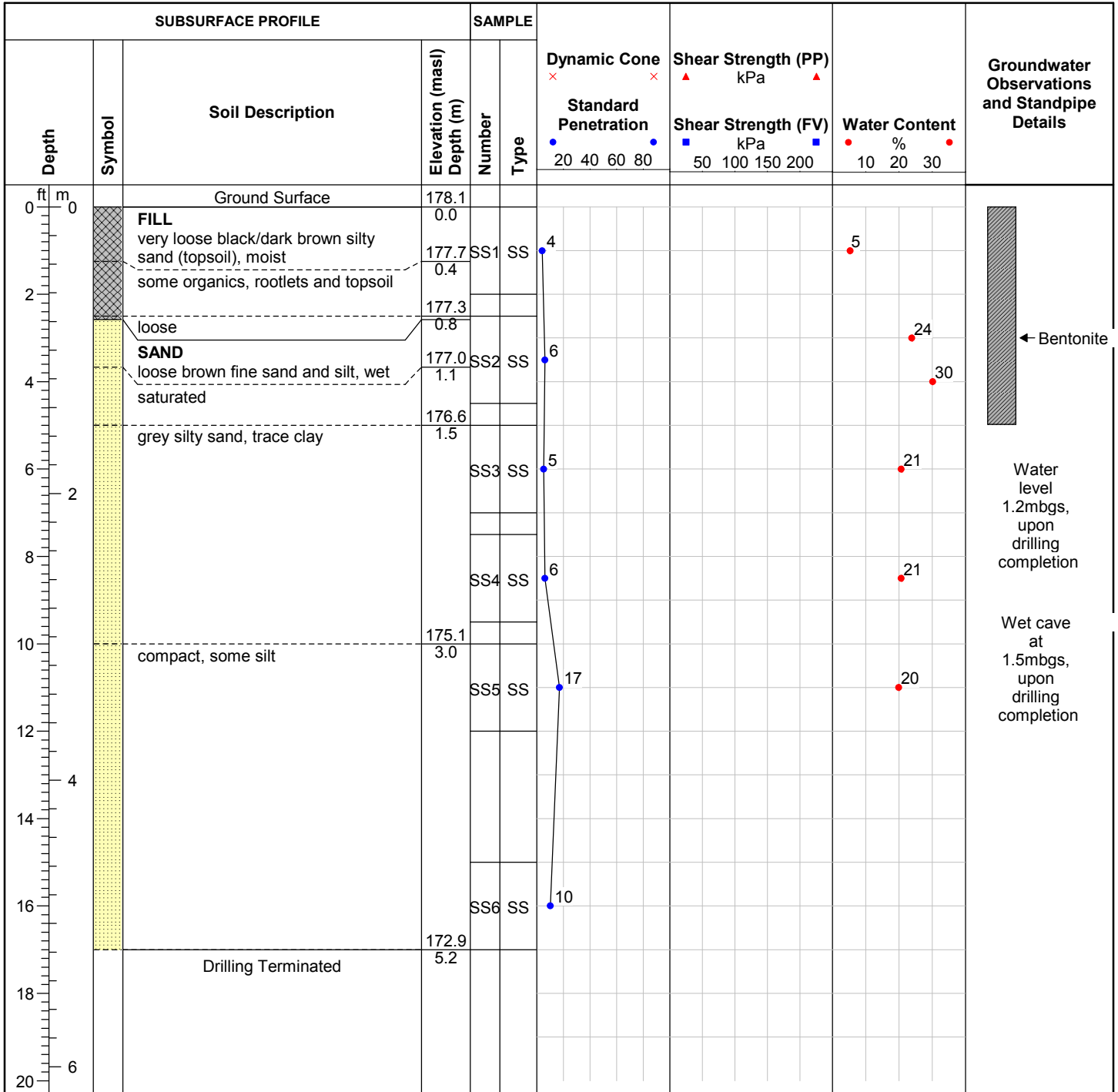

Field Technician: M. Dalgliesh

Drafted by: B. Heinbuch

Reviewed by: M. Wilson



ID Number: BH218-18

Project: Fox Street, Penetanguishene Development

Project No: 43022-100

Client: Wilmington Capital Management Inc.

Site Location: 160 - 200 Fox Street, Penetanguishene, ON

Drill Date: 4/9/2018

Drilling Contractor: Direct Environmental Drilling

Drill Rig: Geoprobe 7822DT

Drill Method: Hollow Stem Augers

Protective Cover: N/A

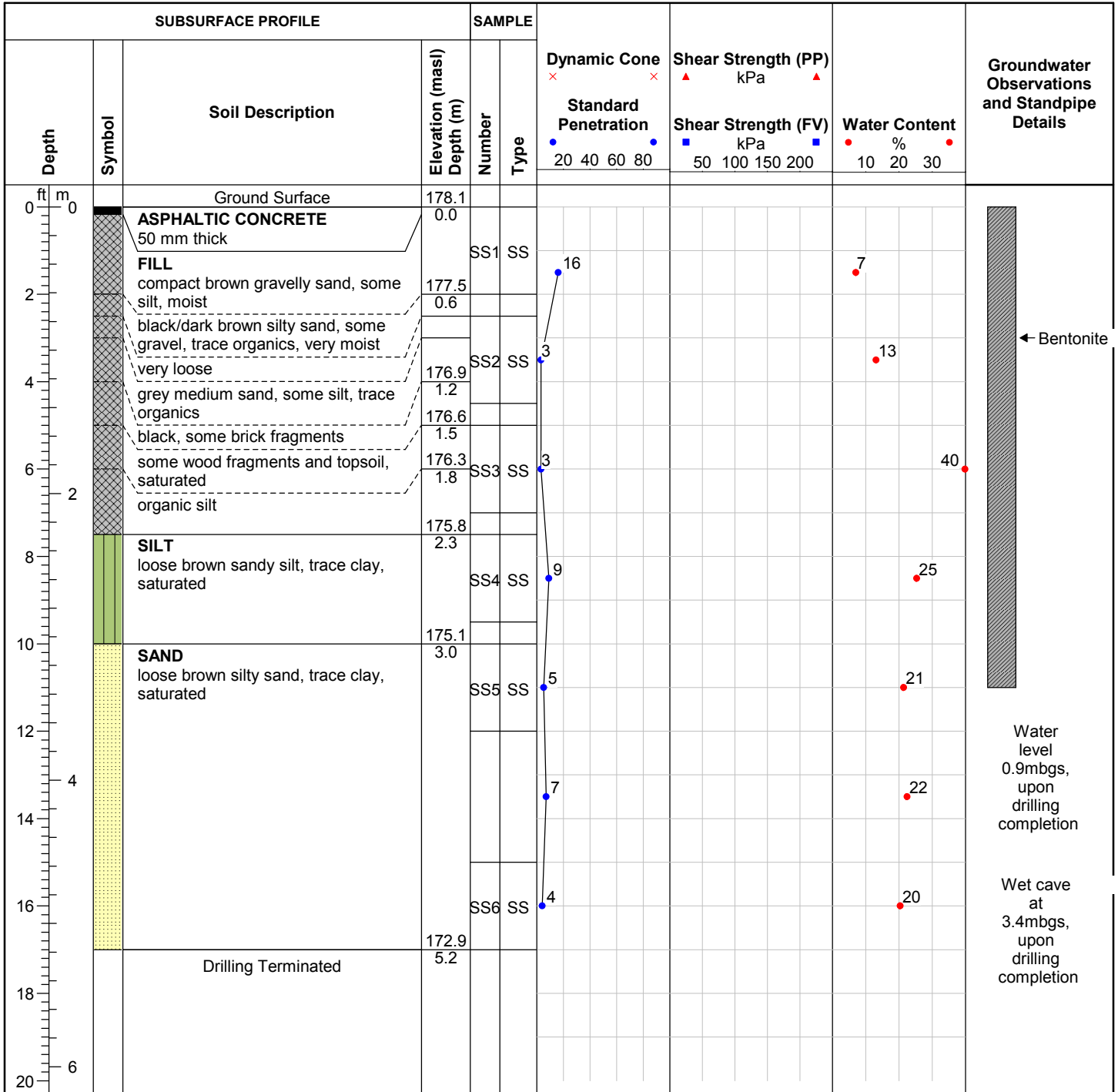

Field Technician: M. Dalgliesh

Drafted by: B. Heinbuch

Reviewed by: M. Wilson



ID Number: BH219-18

Project: Fox Street, Penetanguishene Development

Project No: 43022-100

Client: Wilmington Capital Management Inc.

Site Location: 160 - 200 Fox Street, Penetanguishene, ON

Drill Date: 4/9/2018

Drilling Contractor: Direct Environmental Drilling

Drill Rig: Geoprobe 7822DT

Drill Method: Hollow Stem Augers

Protective Cover: N/A

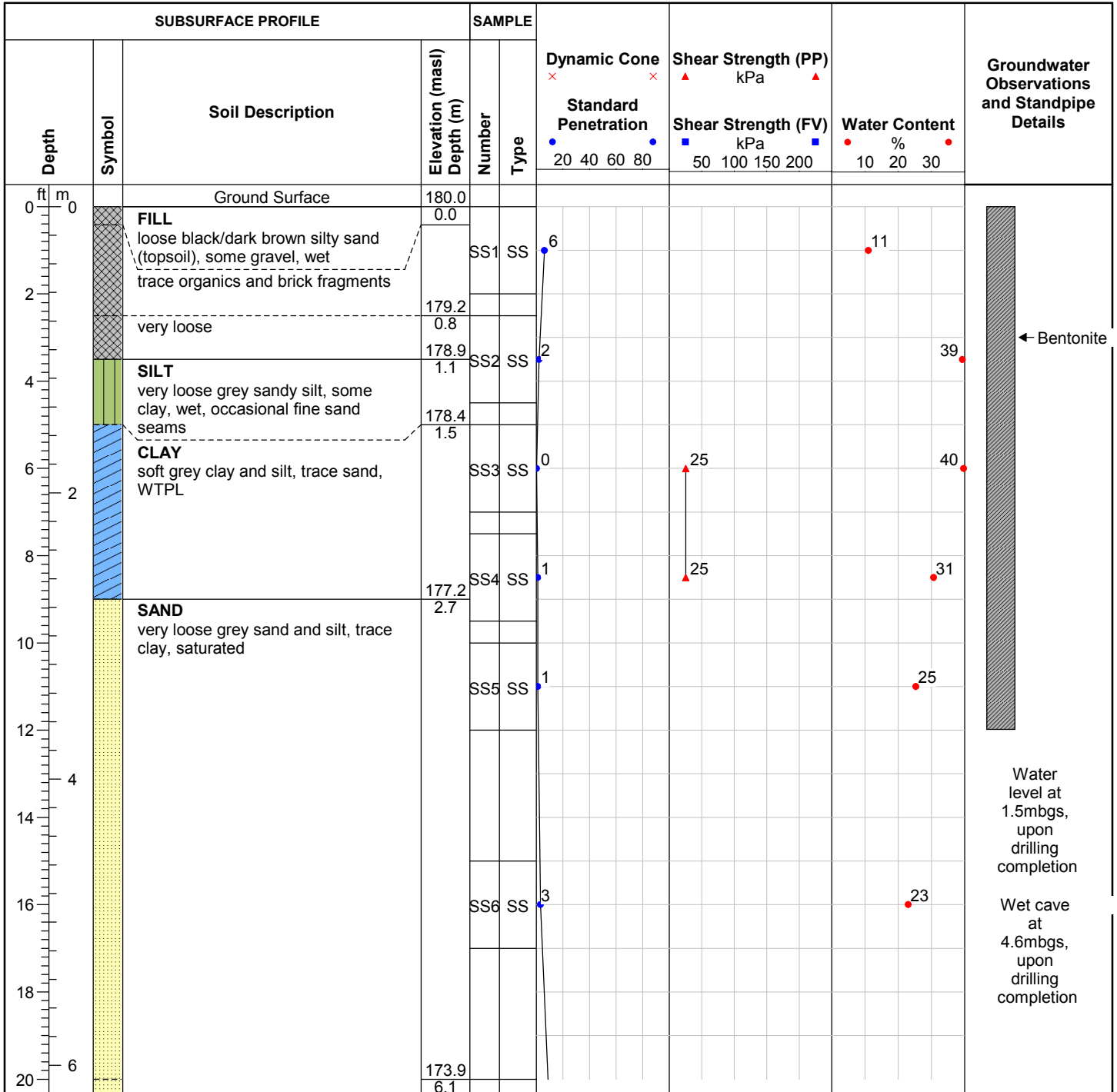

Field Technician: M. Dalgliesh

Drafted by: B. Heinbuch

Reviewed by: M. Wilson



ID Number: BH219-18

Project: Fox Street, Penetanguishene Development

Project No: 43022-100

Client: Wilmington Capital Management Inc.

Site Location: 160 - 200 Fox Street, Penetanguishene, ON

Drill Date: 4/9/2018

Drilling Contractor: Direct Environmental Drilling

Drill Rig: Geoprobe 7822DT

Drill Method: Hollow Stem Augers

Protective Cover: N/A

SUBSURFACE PROFILE				SAMPLE		Dynamic Cone × ×	Shear Strength (PP) ▲ kPa ▲	Water Content ● % ●	Groundwater Observations and Standpipe Details
Depth	Symbol	Soil Description	Elevation (masl) Depth (m)	Number	Type				
22	8	compact gravelly sand, some silt	171.7	SS7	SS	10		12	
26				SS8	SS	11		11	
28		Drilling Terminated	8.2						
30									
32	10								
34									
36									
38									
40	12								

Field Technician: M. Dalgliesh

Drafted by: B. Heinbuch

Reviewed by: M. Wilson



ID Number: BH220-18

Project: Fox Street, Penetanguishene Development

Project No: 43022-100

Client: Wilmington Capital Management Inc.

Site Location: 160 - 200 Fox Street, Penetanguishene, ON

Drill Date: 4/9/2018

Drilling Contractor: Direct Environmental Drilling

Drill Rig: Geoprobe 7822DT

Drill Method: Hollow Stem Augers

Protective Cover: N/A

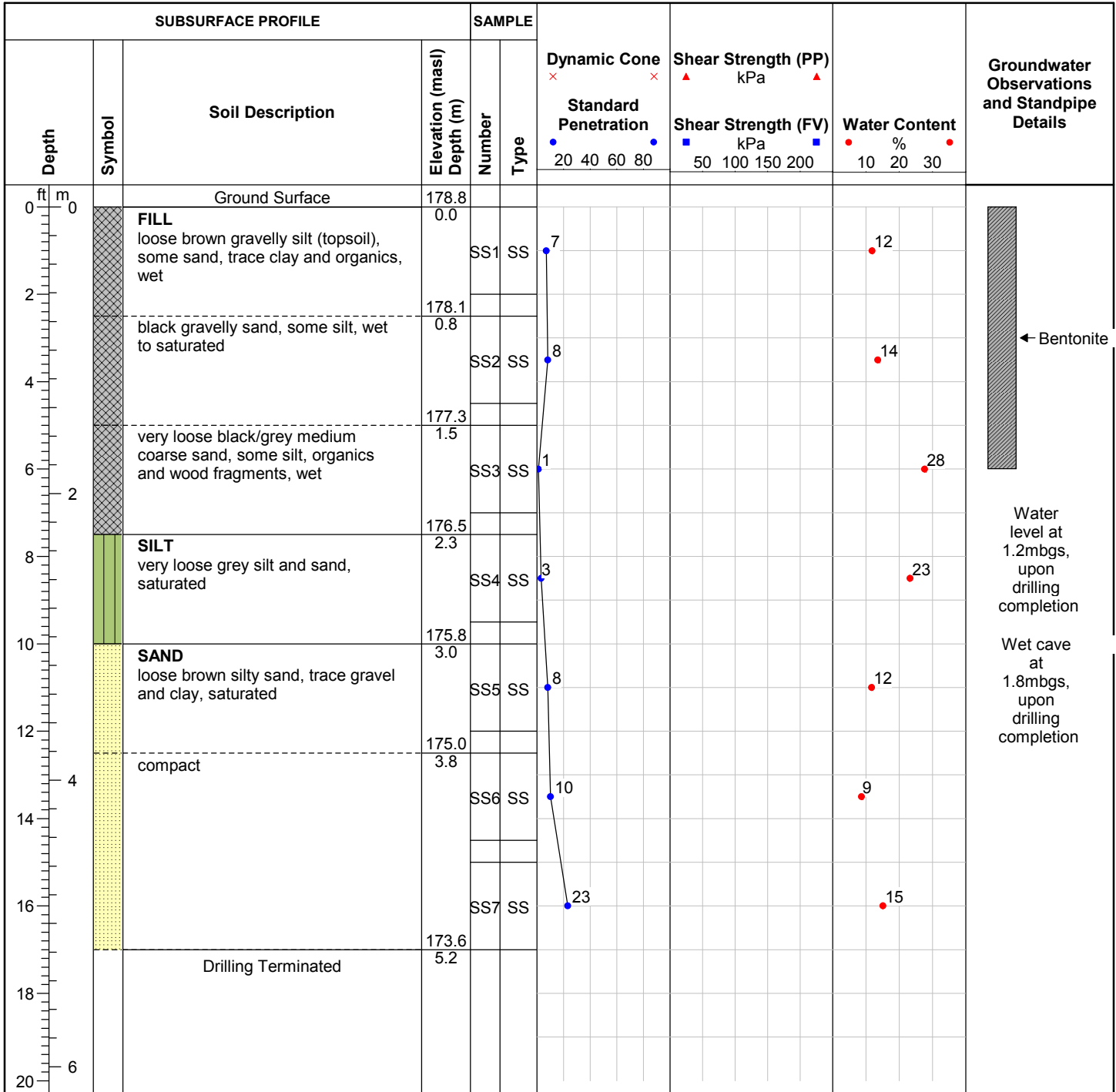

Field Technician: M. Dalglish

Drafted by: B. Heinbuch

Reviewed by: M. Wilson



LABORATORY TEST RESULTS

Table 1 – Particle Size Distribution Analyses
Table 2 – Grain Size Distribution Analysis



Particle Size Distribution Analysis Test Results

PROJECT NAME: Fox Street Penetanguishene
 CLIENT: Wilmington Capital Inc.

DATE SAMPLED: Apr. 9, 2018
 DATE TESTED: Apr. 24-27, 2018

FILE No.: 43022-100
 TABLE #: 1

Unified Soil Classification

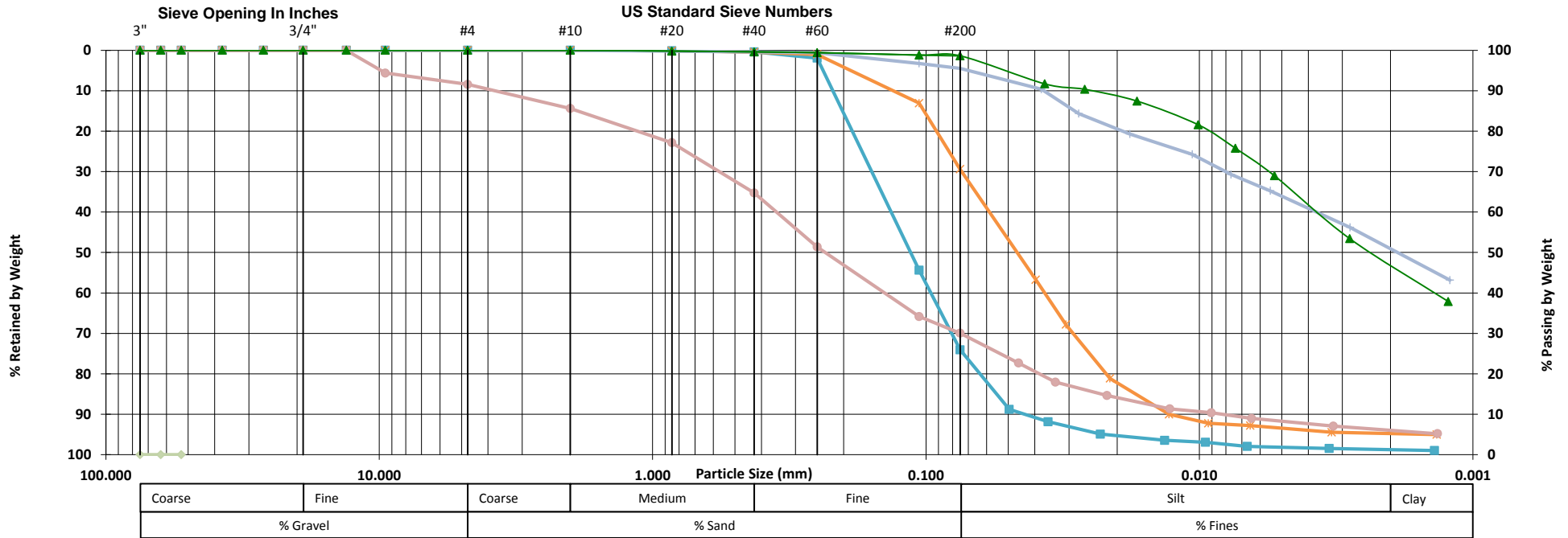

Symbol	Borehole ID	Sample #	Sample Depth	Description
■	BH217-18	SS-5	3.05 - 3.66 mbgs	SILT and CLAY, trace Sand
✱	BH218-18	SS-3	1.52 - 2.13 mbgs	Silty SAND, trace Clay
◆	BH219-18	SS-4	2.29 - 2.90 mbgs	Sandy SILT, trace Clay
●	BH220-18	SS-3	1.52 - 2.13 mbgs	CLAY and SILT, trace Sand
▲		SS-5	3.05 - 3.66 mbgs	Silty SAND, trace Gravel and Clay



NOTES:



LABORATORY TEST RESULTS

PROJECT NAME: Fox Street Penetanguishene

CLIENT: Wilmington Capital Inc.

FILE NO.: 43022-100

DATE: April 10, 2018

DATE SAMPLED: April 9, 2018

LAB NO.: S90G

BOREHOLE ID: BH216-18

DATE TESTED: April 23, 2018

SAMPLE INFO: SS-7 4.57-5.18mbgs

TESTED BY: M.Dalgliesh

TABLE NO.: 2

SIEVE ANALYSIS OF AGGREGATE

SIEVE SIZE (mm)	% PASSING
150	100.0
100	100.0
63.0	100.0
53.0	100.0
37.5	100.0
26.5	100.0
22.0	100.0
19.0	100.0
16.0	100.0
13.2	100.0
9.50	100.0
6.75	100.0
4.75	100.0
2.36	99.7
1.18	98.4
0.600	85.7
0.300	33.4
0.150	5.1
0.075	1.7



NOTES:



**TENSAR INTERNATIONAL CORPORATION
PRODUCT INFORMATION**



SpectraPave4 PRO™ Subgrade Stabilization Design Analysis



DESIGN PARAMETERS

DESIGN REQUIREMENTS

Property	Value
Axle Load (kN)	80
Tire Pressure (kPa)	552
Axle Passes (Each)	12000
Maximum Rut Depth (mm)	40

PAVEMENT SOIL PROPERTIES

Property	Value
Aggregate Fill CBR (%)	20
Soaked Subgrade CBR (%)	0.8

Aggregate fill shall conform to following requirement:
D50 ≤ 27mm

RESULTS

Geosynthetic	Aggregate Fill Thickness (mm)		Aggregate Fill Thickness Savings (mm)	
	Calculated	Required	(mm)	(%)
Unstabilized	840.9	850	N/A	N/A
TX140	509.0	510	340	40
TX160	403.1	410	440	52

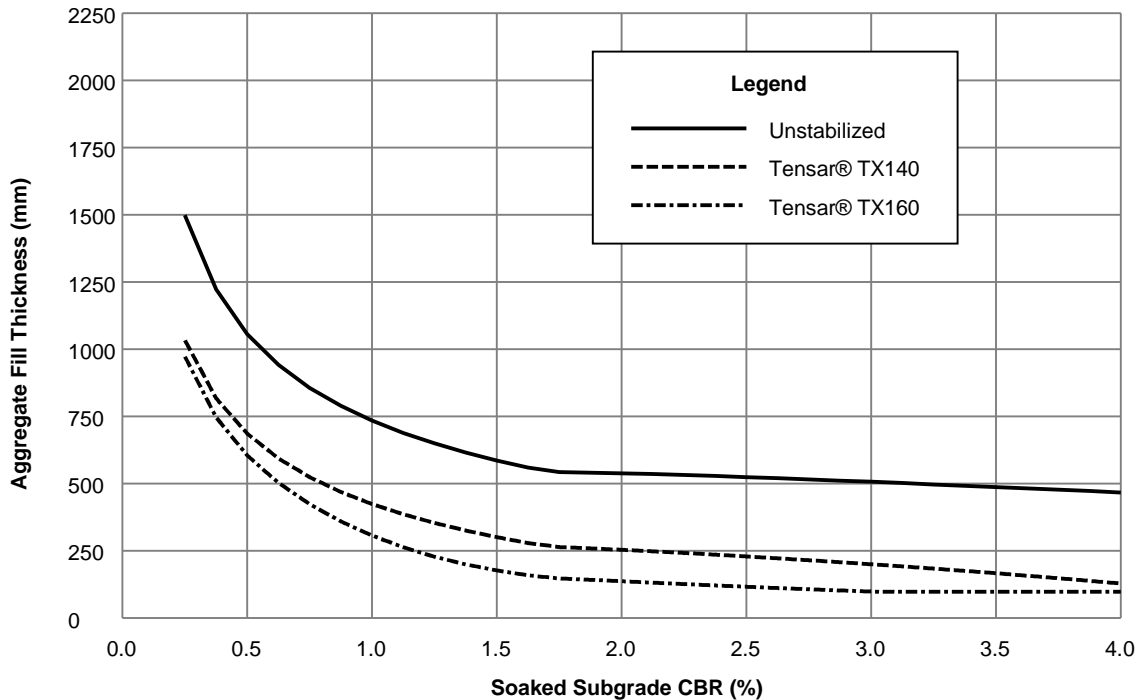

Project Name	Fox Street, Penetanguishene		
Company Name	MTE		
Designer		Date	

Product Specification - TriAx® TX140 Geogrid

Tensor International Corporation reserves the right to change its product specifications at any time. It is the responsibility of the person specifying the use of this product and of the purchaser to ensure that product specifications relied upon for design or procurement purposes are current and that the product is suitable for its intended use in each instance.

Tensor TriAx® Geogrid

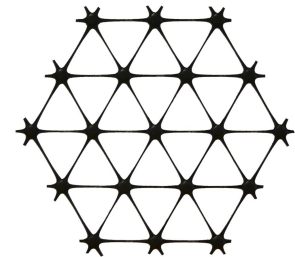

General

1. The geogrid is manufactured from a punched polypropylene sheet, which is then oriented in three substantially equilateral directions so that the resulting ribs shall have a high degree of molecular orientation, which continues at least in part through the mass of the integral node.
2. The properties contributing to the performance of a mechanically stabilized layer include the following:

Index Properties	Longitudinal	Diagonal	Transverse	General
▪ Rib pitch ⁽²⁾ , mm (in)	40 (1.60)	40 (1.60)	-	
▪ Mid-rib depth ⁽²⁾ , mm (in)	-	1.2 (0.05)	1.2 (0.05)	
▪ Mid-rib width ⁽²⁾ , mm (in)	-	1.1 (0.04)	1.1 (0.04)	
▪ Rib shape				rectangular
▪ Aperture shape				triangular

Structural Integrity

▪ Junction efficiency ⁽³⁾ , %				93
▪ Aperture stability ⁽⁴⁾ , kg-cm/deg @ 5.0kg-cm ⁽²⁾				3.0
▪ Radial stiffness at low strain ⁽⁵⁾ , kN/m @ 0.5% strain (lb/ft @ 0.5% strain)				225 (15,430)

Durability

▪ Resistance to chemical degradation ⁽⁶⁾				100%
▪ Resistance to ultra-violet light and weathering ⁽⁷⁾				100%

Dimensions and Delivery

The TX Geogrid shall be delivered to the jobsite in roll form with each roll individually identified and nominally measuring 3.0 meters (9.8 feet) and/or 4.0 meters (13.1feet) in width and 75 meters (246 feet) in length.

Notes

1. Unless indicated otherwise, values shown are minimum average roll values determined in accordance with ASTM D4759-02. Brief descriptions of test procedures are given in the following notes.
2. Nominal dimensions.
3. Load transfer capability determined in accordance with GRI-GG2-87 and GRI-GG1-87 and expressed as a percentage of ultimate tensile strength.
4. In-plane torsional rigidity measured by applying a moment to the central junction of a 225mm x 225mm specimen restrained at its perimeter in accordance with GRI-GG9 modified.
5. Radial stiffness is determined from tensile stiffness measured in any in-plane axis from testing in accordance with ASTM D6637-10.
6. Resistance to loss of load capacity or structural integrity when subjected to chemically aggressive environments in accordance with EPA 9090 immersion testing.
7. Resistance to loss of load capacity or structural integrity when subjected to 500 hours of ultraviolet light and aggressive weathering in accordance with ASTM D4355-05.

Tensor International Corporation
2500 Northwinds Parkway, Suite 500
Alpharetta, Georgia 30009

Phone: 800-TENSAR-1
www.tensor-international.com

This specification supersedes any and all prior specifications for the product designated above and is not applicable to any product shipped prior to February 1, 2011. Tensor and TriAx are trademarks of Tensor International Corporation or its affiliates in the US and many other countries. TriAx® geogrid and the use thereof are protected by U.S. Patent No. 7,001,112. Patents or patent applications also exist in other countries. Final determination of the suitability of the above-mentioned information or product for the use contemplated, and its manner of use are the sole responsibility of the user. Tensor International Corporation disclaims any and all express, implied or statutory warranties, including but not limited to, any warranty of merchantability or fitness for a particular purpose regarding this product or the Company's other products, technologies or services. The information contained herein does not constitute engineering advice.

Product Specification - TriAx® TX160 Geogrid

Tensar International Corporation reserves the right to change its product specifications at any time. It is the responsibility of the person specifying the use of this product and of the purchaser to ensure that product specifications relied upon for design or procurement purposes are current and that the product is suitable for its intended use in each instance.

Tensar TriAx® Geogrid

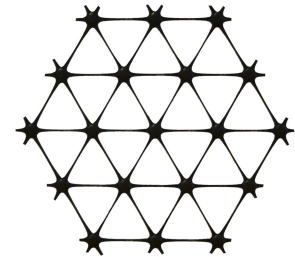

General

1. The geogrid is manufactured from a punched polypropylene sheet, which is then oriented in three substantially equilateral directions so that the resulting ribs shall have a high degree of molecular orientation, which continues at least in part through the mass of the integral node.
2. The properties contributing to the performance of a mechanically stabilized layer include the following:

Index Properties	Longitudinal	Diagonal	Transverse	General
▪ Rib pitch ⁽²⁾ , mm (in)	40 (1.60)	40 (1.60)	-	
▪ Mid-rib depth ⁽²⁾ , mm (in)	-	1.6 (0.06)	1.4 (0.06)	
▪ Mid-rib width ⁽²⁾ , mm (in)	-	1.0 (0.04)	1.2 (0.05)	
▪ Rib shape				rectangular
▪ Aperture shape				triangular

Structural Integrity

▪ Junction efficiency ⁽³⁾ , %				93
▪ Aperture stability ⁽⁴⁾ , kg-cm/deg @ 5.0kg-cm ⁽²⁾				3.6
▪ Radial stiffness at low strain ⁽⁵⁾ , kN/m @ 0.5% strain (lb/ft @ 0.5% strain)				300 (20,580)

Durability

▪ Resistance to chemical degradation ⁽⁶⁾				100%
▪ Resistance to ultra-violet light and weathering ⁽⁷⁾				100%

Dimensions and Delivery

The TX Geogrid shall be delivered to the jobsite in roll form with each roll individually identified and nominally measuring 3.0 meters (9.8 feet) and/or 4.0 meters (13.1feet) in width and 75 meters (246 feet) in length.

Notes

1. Unless indicated otherwise, values shown are minimum average roll values determined in accordance with ASTM D4759-02. Brief descriptions of test procedures are given in the following notes.
2. Nominal dimensions.
3. Load transfer capability determined in accordance with GRI-GG2-87 and GRI-GG1-87 and expressed as a percentage of ultimate tensile strength.
4. In-plane torsional rigidity measured by applying a moment to the central junction of a 225mm x 225mm specimen restrained at its perimeter in accordance with GRI-GG9 modified.
5. Radial stiffness is determined from tensile stiffness measured in any in-plane axis from testing in accordance with ASTM D6637-10.
6. Resistance to loss of load capacity or structural integrity when subjected to chemically aggressive environments in accordance with EPA 9090 immersion testing.
7. Resistance to loss of load capacity or structural integrity when subjected to 500 hours of ultraviolet light and aggressive weathering in accordance with ASTM D4355-05.

Tensar International Corporation
2500 Northwinds Parkway, Suite 500
Alpharetta, Georgia 30009

Phone: 800-TENSAR-1
www.tensar-international.com

This specification supersedes any and all prior specifications for the product designated above and is not applicable to any product shipped prior to February 1, 2011. Tensar and TriAx are trademarks of Tensar International Corporation or its affiliates in the US and many other countries. TriAx® geogrid and the use thereof are protected by U.S. Patent No. 7,001,112. Patents or patent applications also exist in other countries. Final determination of the suitability of the above-mentioned information or product for the use contemplated, and its manner of use are the sole responsibility of the user. Tensar International Corporation disclaims any and all express, implied or statutory warranties, including but not limited to, any warranty of merchantability or fitness for a particular purpose regarding this product or the Company's other products, technologies or services. The information contained herein does not constitute engineering advice.

Geogrid Specifications

Provisional use of Geogrids for Subgrade Stabilization

Geogrid shall be Tensar TX140 or TX160 as manufactured by Tensar International and supplied by Terrafix Geosynthetics. Material selection and design for the Mechanically Stabilized Layer shall be carried out as follows:

The Mechanical Stabilized Layer shall be designed in accordance with the Giroud-Han Method (Giroud and Han, 2004) of unpaved road design.

Approved Alternatives:

In-air index testing of geogrid properties, or explanation of performance based on in-air index testing of geogrid properties are not sufficient to understand the complex mechanisms involved in soil-geogrid interaction and/or the performance of Mechanically Stabilized Layers. Therefore, no acceptance of alternates based on material index property comparisons or explanations of performance based on in-air testing of geogrid properties will be allowed.

Any submittal for an alternative Mechanically Stabilized Layer design must be submitted at least 2 weeks in advance of the bid date and must be accompanied with the following:

- A design signed and sealed by a professional engineer registered to practice in the Province of Ontario.
- Unpaved design- A written statement from the alternative Mechanically Stabilized Layer design engineer of record that the design is based upon the Giroud-Han Method and that proper calibration and validation testing has been performed for the geogrid reinforcement utilized in the Mechanically Stabilized Layer in accordance with these specifications.
- A submittal package that includes documented evidence of proper calibration and validation testing.



APPENDIX E

EBS GEOSTRUCTURAL INC. HELICAL PILE INFORMATION

DISCLAIMER

1. The information and sketches contained in these drawings are given as guidelines only.
2. Capacities of Chance Helical Piles/Anchors may vary depending on, but not limited to, water table elevation and changes to that elevation, changing soil conditions, soil layer thicknesses.
3. Achievable capacities could be higher or lower than ratings due to site-specific conditions. On site load testing should be performed to confirm additional pile/anchor capacities.
4. Installed capacities to be verified on site by a registered Professional Engineer.
5. The information contained herein is to be used for preliminary design activities only, and subject to EBS' Website Disclaimer.

TWIN & TRIPLE SS5 HELICAL PIERS / ANCHORS

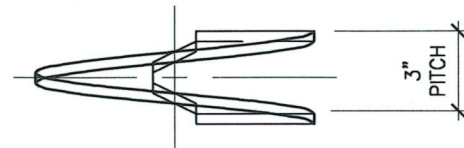

HELIX MUST BE FORMED BY MATCHING METAL DIE (SIDE VIEW OF TRUE HELICAL FORM)

NOTES

1. HOT DIP GALVANIZED PER ASTM A153--(LATEST REV.)
2. SHAFT MATERIAL--HOT ROLLED ROUND--CORNERED SQUARE (RCS) SOLID STEEL BARS PER ASTM A29; MINIMUM YIELD STRENGTH=70 KSI.
3. HELIX MATERIAL--HOT ROLLED LOW CARBON STEEL SHEET, STRIP, OR PLATE PER ASTM A572, OR A1018, OR A656; MINIMUM YIELD STRENGTH=50 KSI; 3/8" THICK.
4. COUPLING BOLTS: 3/4" DIAMETER X 3" LONG HEX HEAD PER ASTM A320 GRADE L7.
5. NOMINAL SPACING BETWEEN HELICAL PLATES IS THREE TIMES THE DIAMETER OF THE LOWER HELIX.
6. MANUFACTURER TO HAVE IN EFFECT INDUSTRY RECOGNIZED WRITTEN QUALITY CONTROL FOR ALL MATERIALS AND MANUFACTURING PROCESSES.
7. ALL WELDING TO BE COMPLETED BY WELDERS CERTIFIED UNDER SECTION 5 OF THE AWS CODE D1.1.
8. ALL HELICES HAVE A SHARPENED LEADING EDGE.
9. TORQUE STRENGTH RATING--5,500 FT--LB.
10. ULTIMATE CAPACITY (TENSION/COMPRESSION)--55 KIP, BASED ON A TORQUE FACTOR (Kt)=10.
11. ULTIMATE TENSION STRENGTH (COUPLING BOLT)--70 KIP.

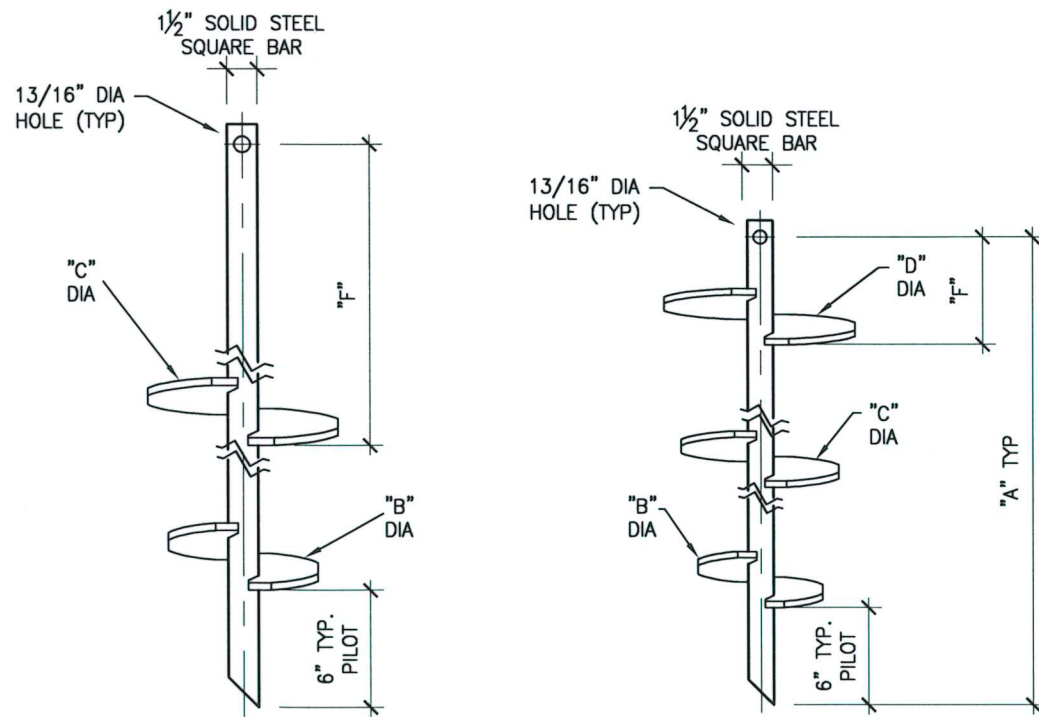

LEAD SECTION

SCALE: N.T.S.

LEAD SECTION				
"A"	"B"	"C"	"D"	"F"
82-1/4"	6"	8"		58-1/4"
82-1/4"	8"	10"		52-1/4"
82-1/4"	10"	12"		46-1/4"
63-1/4"	8"	10"	12"	5-3/4"
82-1/4"	10"	12"	14"	10-1/4"

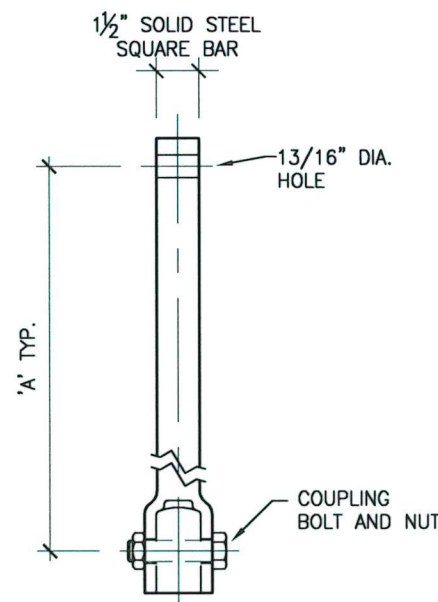

PLAIN EXTENSION

SCALE: N.T.S.

EXTENSION
"A"
57-1/2"
80-1/2"
120"

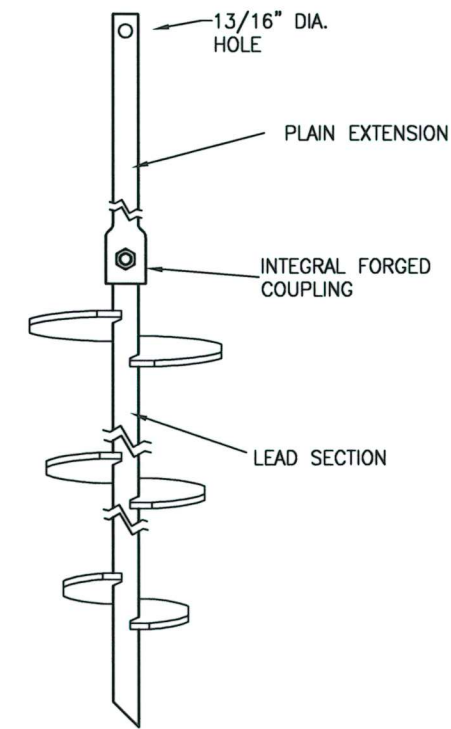

TYPICAL PIER / ANCHOR ASSEMBLY

SCALE: N.T.S.

EBS is an authorized distributor of A.B. Chance Civil Construction products.

CHANCE™
Since 1912

Registered trademark of A.B. Chance, a division of Hubbell Power Systems, Inc.

320 Woolwich Street South, Breslau, Ontario N0B 1M0
Tel: 519-648-3613 Fax: 519-648-2526
Email: info@ebsgeo.com

PROJECT:	SAMPLE		
DRAWING:	SS5 HELICAL PIERS / ANCHORS		
DRW'N BY:	SCALE:	N.T.S.	
CHECKED:	DATE:	NOVEMBER 2012	
PROJECT No.:	DWG. No.:		

DISCLAIMER

1. The information and sketches contained in these drawings are given as guidelines only.
2. Capacities of Chance Helical Piles/Anchors may vary depending on, but not limited to, water table elevation and changes to that elevation, changing soil conditions, soil layer thicknesses.
3. Achievable capacities could be higher or lower than ratings due to site-specific conditions. On site load testing should be performed to confirm additional pile/anchor capacities.
4. Installed capacities to be verified on site by a registered Professional Engineer.
5. The information contained herein is to be used for preliminary design activities only, and subject to EBS' Website Disclaimer.

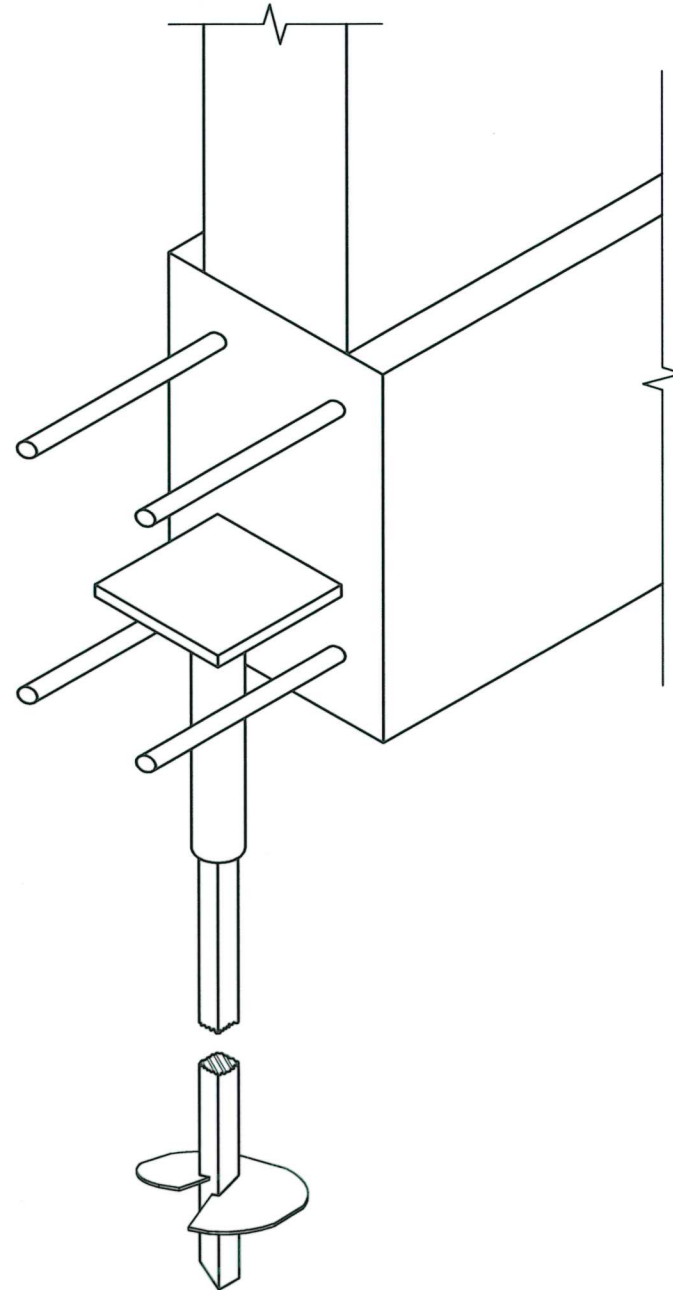

**INSTALLATION CONCEPT OF
PIER CAP DETAIL**

SCALE: N.T.S.

NEW CONSTRUCTION BRACKET

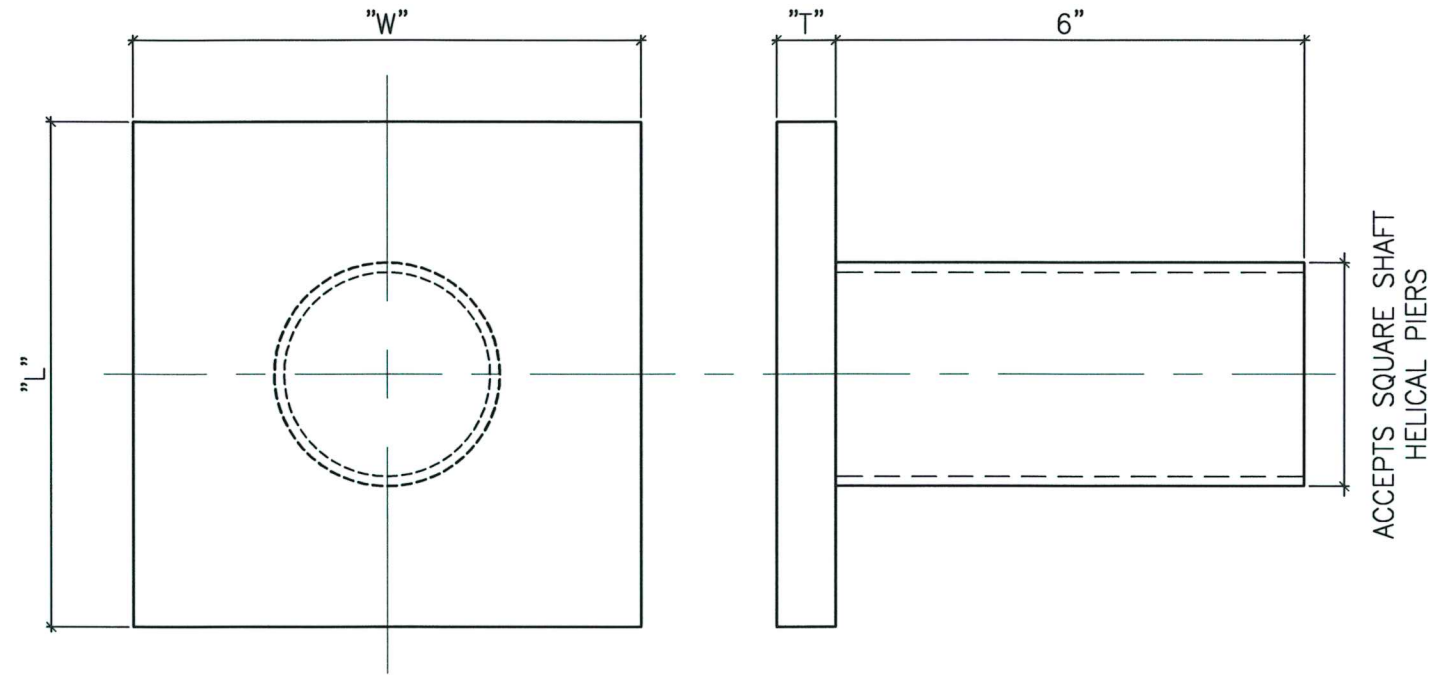

**NEW CONSTRUCTION
BRACKET**

SCALE: N.T.S.

ACCEPTS SQUARE SHAFT
HELICAL PIERS

NEW CONSTRUCTION BRACKET SIZES

HELICAL SS TYPE	"L"	"W"	"T"	SERVICE LOAD RATING
SS5	6"	6"	1/2"	25 KIP
SS175	6-1/2"	6-1/2"	3/4"	55 KIP
SS200	8"	8"	1"	80 KIP
SS225	9"	9"	1"	100 KIP

NOTES

1. FINISH: MILL FINISH STEEL.
2. PIPE: STEEL TUBE, ROUND, PER ASTM A500 GRADE B OR EQUIVALENT.
3. PLATE: PER ASTM A36 OR EQUIVALENT.
4. RATING: RATING IS VALID ONLY IF THE PIER CAP DETAIL HAS BEEN DESIGNED TO ENSURE ADEQUATE LOAD TRANSFER FROM REINFORCED CONCRETE FOUNDATION TO HELICAL PIER, AND IN ACCORDANCE WITH EXISTING LOCAL CODE REQUIREMENTS AND /OR ESTABLISHED LOCAL PRACTICES.



320 Woolwich Street South, Breslau, Ontario N0B 1M0
Tel: 519-648-3613 Fax: 519-648-2526
Email: info@ebsgeo.com

PROJECT: SAMPLE

DRAWING: NEW CONSTRUCTION BRACKET

DRW'N BY:	SCALE: N.T.S.
CHECKED:	DATE: NOVEMBER 2012
PROJECT No.:	DWG. No.:

GEOTECHNICAL CAPACITIES OF SQUARE SHAFT ■ HELICAL PILES

SOIL PROPERTIES		PRODUCT TYPE	COMPRESSION CAPACITY		TENSION CAPACITY	
"N" VALUE COHESIVE	"N" VALUE NON- COHESIVE	SQUARE SHAFT SIZE mm (INCHES)	SLS kN (KIPS)	ULS kN (KIPS)	SLS kN (KIPS)	ULS kN (KIPS)
25–35	25–30	* SS5 38 (1.5)	200 (45)	270 (60)	60 (13)	80 (18)
35–45	30–35	SS175 44 (1.75)	370 (83)	500 (113)	135 (30)	150 (33)
50–60	40–50	SS200 51 (2)	500 (112)	670 (150)	165 (37)	215 (48)
65–100	55–100	SS225 57 (2.25)	680 (153)	915 (206)	240 (54)	310 (70)

* Ability to install in tight access (3ft wide) and low headroom (6ft high)

GEOTECHNICAL CAPACITIES OF ROUND SHAFT HELICAL PILES

SOIL PROPERTIES		PRODUCT TYPE	COMPRESSION CAPACITY		TENSION CAPACITY	
"N" VALUE COHESIVE	"N" VALUE NON-COHESIVE	DIAMETER mm (INCHES)	SLS kN (KIPS)	ULS kN (KIPS)	SLS kN (KIPS)	ULS kN (KIPS)
20–25	15–20	* RS2875 73 (2.875)	115 (26)	155 (35)	50 (11)	65 (15)
25–30	20–25	RS3500 89 (3.5)	210 (47)	280 (64)	90 (20)	120 (27)
30–35	25–30	RS4500 114 (4.5)	320 (72)	430 (97)	135 (31)	185 (42)
35–40	30–35	RS6625 168 (6.625)	460 (104)	620 (140)	200 (45)	270 (60)
40–45	35–40	RS8625 219 (8.625)	690 (156)	930 (210)	300 (67)	400 (90)
45–50	40–45	RS958 244 (9.625)	950 (214)	1300 (293)	480 (108)	650 (146)

* Ability to install in tight access (3ft wide) and low headroom (6ft high)



“MTE is a trusted advisor to our clients and enhances their projects by providing the right solution in a personal, cost effective and timely manner.”

MTE Consultants Inc.

1016 Sutton Drive, Unit A
Burlington, Ontario L7L 6B8
Phone: 905-639-2552
Fax: 905-639-7727

520 Bingemans Centre Drive
Kitchener, Ontario N2B 3X9
Phone: 519-743-6500
Fax: 519-743-6513

560 Wellington Street, Fourth Floor
London, Ontario N6A 3R4
Phone: 519-204-6510
Fax: 519-204-6511

365 Home Street
Stratford, Ontario N5A 2A5
Phone: 519-271-7952
Fax: 519-271-3545

www.mte85.com

September 4, 2018
Revised February 13, 2019

Mr. Dave Rozycki
3282 Ogden's Beach Road
Midland, ON
L4R 4K6

**Wilson
Associates**

Consulting Hydrogeologists

Dear Mr. Rozycki:

Re: Hydrogeological Study and Water Balance Analysis
Proposed Development of 166, 176 and 200 Fox Street
Town of Penetanguishene

It is proposed to re-develop the existing 6.40ha property at 166, 176 and 200 Fox Street, in the Town of Penetanguishene, as a residential development with detached, semi-detached and townhome buildings. The site is currently in use as a marina and associated facilities.

As requested by WMI & Associates, this report has been prepared to address the requirements of the June 2013 "Hydrogeological Assessment Submissions: Conservation Authority Guidelines for Development Applications" (the CA Guideline).

Provided for this updated study were the following documentation:

- Geotechnical Investigation (Draft), Fox Street Penetanguishene Proposed Development. MTE Consultants Inc. (MTE), May 8, 2018.
- Proposed Site Plan, March 2018.

Copies of the above documentation are attached for reference.

This revised report has been prepared to update the report to the current site plan, dated January 25, 2019, as well as to clarify site references.

LOCATION AND HYDROGEOLOGICAL SETTING

The subject lands at 166, 176 and 200 Fox Street occupy a 6.40ha parcel located on the west side of Fox Street, approximately 240m north of Beck Boulevard and approximately 340m south of Broad Street, within the northern periphery of the Town of Penetanguishene. The lands are situated on the east shore of Penetang Harbour, between Fox Street and the Harbour, and exhibit a generally westwards slope of approximately 4 to 6m between Fox Street and the shore of Penetang Harbour. The lands are currently developed as a marina and associated facilities. The only other surface water body mapped in the vicinity of the site is St. Andrews Lake, located about 1,400m to the east.

Lands in the vicinity of the site are primarily in use as urban residential development, with some lands to the east of Fox Street currently undeveloped.

The subject lands are located within the Simcoe Uplands physiographic region of southern Ontario, an area of northern Simcoe County characterized by till upland plains and steep-sided, flat floored valleys. The site is situated west of, and below, a steep raised shore bluff which was once the shore of glacial Lake Algonquin, the shore bluff being located east of Fox Street.

According to Ontario Geological Survey Open File Map 194 "Quaternary Geology of the Penetanguishene and Christian Island Areas", the upper soils across the site consist of lacustrine coarse-grained deposits (fine to very fine sand, minor pebbly sand and silt). In twenty on-site exploratory boreholes, the native soil profile identified by the MTE report consisted mainly of sand, usually overlying discontinuous silt and clay deposits at depth.

As the area is municipally serviced, few water well records are available in the close vicinity from which to characterize the sequence of lower overburden formations. The Ministry of the Environment, Conservation and Parks (MECP) water well record for a municipal test well (57-12850, copy attached) located nearby to the south of the site (north of Beck Boulevard), indicates that the entire overburden is primarily granular.

According to MECP water well record 57-12850, and interpretation provided by the 2005 North Simcoe Municipal Groundwater Study (NSMGS), the bedrock surface beneath the site is situated at an approximate elevation of 140m above sea level (masl) (per Figure 4.5.2 of the NSMGS). As such, the overburden will be in the range of 42m deep beneath the site. The NSMGS also reports the majority of the overburden to be granular.

The bedrock beneath the site consists mainly of limestone and dolostone of the Simcoe Group.

Although the area is now municipally serviced, historical water wells will have obtained potable groundwater from granular formations in the lower overburden. The bedrock beneath the site is not locally typically used as a source of potable groundwater due to the likelihood of obtaining lower yields of aesthetically-poorer quality groundwater.

According to the 2015 Severn Sound Source Protection Area Approved Assessment Report (the Severn Sound Report), the site is not located within a Well Head Protection Zone. The Severn Sound Report also indicates that the municipal well site to the south, referenced by MECP water well record 57-12850, is no longer in use as a municipal well site. Furthermore, an MECP water well record prepared by International Water Supply in 2007 (no well record number) indicates that a historical municipal water well located to the south of the site was abandoned (record attached).

WATERTABLE

Watertable levels were observed by MTE in open boreholes and in two boreholes equipped as monitoring wells, and are summarized in Table 4 of the MTE report. To generally summarize the MTE Table 4 data, shallow groundwater conditions are reported across the site, with reported watertable levels ranging from between 1.5m to 2.9m below grade in boreholes within the eastern portion of the site near Fox Street to between 0.31m and 1.22m below grade within the western portion of the site near Penetang Harbour. The watertable surface reported by MTE slopes in a westwards direction from an approximate elevation of 179masl within the eastern portion of the site near Fox Street down to an approximate elevation of 176.9masl along the shore of Penetang Harbour. Based on the MTE water level data, a westwards direction of shallow groundwater flow is inferred.

Locally (i.e. the area between Penetang Harbour and St. Andrews Lake), Figures 4.4.1 and 4.4.2 of the NSMGS indicates a westward direction of groundwater flow. Figure 4.4.5 of the NSGMS classifies the site as a major groundwater discharge area.

SHALLOW GROUNDWATER QUALITY

To establish background shallow groundwater quality, a sample of shallow groundwater was collected from MTE BH/MW202-18 on June 14, 2018. The sample was collected using a Waterra inertial pump after purging the well of 20L of standing water (approximately 3 casing volumes). The water sample was collected in laboratory-supplied bottles, stored in an ice-packed cooler and submitted to Maxxam Analytics Inc. under chain of custody for an analysis of general chemistry and heavy metals parameters.

The analytical results indicate that for the parameters determined, most parameters (including sodium, chloride and nitrate) were at relatively low levels typical of shallow groundwater in a municipally-serviced area. The dissolved organic carbon content of the sample was slightly elevated at 8.4mg/L (above the Ontario Drinking Water Quality Standard (ODWQS) of 5mg/L), which is not unexpected in a low-lying groundwater discharge area. The manganese content of the sample at 1.4mg/L is elevated, above the ODWQS of 0.05mg/L, and is also not unexpected in a low-lying groundwater discharge area. The total dissolved solids (TDS) content of the sample at 550mg/L is slightly elevated above the ODWQS of 500mg/L, however the elevated TDS is not related to road salting, and appears to be naturally-occurring.

A copy of the analytical results are attached.

WATER BUDGET ANALYSIS

The following assumptions are made for this assessment:

- Overall drainage from the site is generally westwards following site topography, and for water budget analysis, the site is assumed to act as one catchment. The site is considered to exhibit a rolling to hilly topography (per the 1995 MECP definitions referenced by the CA guideline) and sandy soil conditions.
- According to calculations provided by WMI & Associates Limited, the 6.40ha site currently exhibits a pervious area of 43% (2.75ha) and an impervious area of 57% (3.65ha). The proposed re-development of the site will exhibit a pervious area of 51% (3.26ha) and an impervious area of 49% (3.14ha). For the purposes of this assessment, it is assumed that infiltration rates will need to be maintained to pre-development conditions, that being prior to the development of the marina facility (i.e. 100% pervious conditions).
- The water surplus for the site is assumed to be 406mm/year, as identified for the Penetanguishene and Tay Point subwatershed by the 2015 Severn Sound Report (precipitation 992mm/year, actual evapotranspiration 586mm/year). Normal precipitation for the area is 1040.6mm/year (1981-2010 precipitation normal for the closest Environment Canada weather station - Midland WPCP weather station). For this assessment, the 2015 Severn Sound Report precipitation rate of 992mm/year is assumed.

The following tables provide a water budget analysis following the general guidance of the April 2013 Conservation Authority Guidelines for Hydrogeological Assessments.

Table 1 - Water Budget - Undeveloped (pre-marina) Conditions

Catchment Designation	Site	
	Undeveloped	Totals
Area (m ²)	64000	64000
Pervious Area (m ²)	64000	64000
Impervious Area (m ²)	0	0
Impervious Factors (Per MECP Guidelines referenced by CA Guideline)		
Topography Infiltration Factor	Rolling to Hilly 0.15	
Soil Infiltration Factor	Sand 0.4	
Land Cover Infiltration Factor	Cleared 0.1	
MOECC Infiltration Factor	0.65	
Actual Infiltration Factor	0.65	
Run-Off Coefficient	0.35	
Runoff from Impervious Surfaces*	0	
Inputs (per Unit Area)		
Precipitation (mm/year)	992	992
Run-On (mm/year)	0	0
Other Inputs (mm/year)	0	0
Total Inputs (mm/year)	992	992
Outputs (per Unit Area)		
Precipitation Surplus (mm/year)	406	406
Net Surplus (mm/year)	406	406
Evapotranspiration (mm/year)	586	586
Infiltration (mm/year)	264	264
Impervious Area Infiltration (mm/year)	0	0
Total Infiltration (mm/year)	264	264
Runoff Pervious Areas (mm/year)	142	142
Runoff Impervious Areas (mm/year)	0	0
Total Runoff (mm/year)	142	142
Total Outputs (mm/year)	992	992
Difference (Inputs - Outputs) (mm/year)	0	0

Inputs (Volume)		
Precipitation (m ³ /year)	63488	63488
Run-On (m ³ /year)	0	0
Other Inputs (m ³ /year)	0	0
Total Inputs (m³/year)	63488	63488
Outputs (Volume)		
Precipitation Surplus (m ³ /year)	25984	25984
Net Surplus (m ³ /year)	25984	25984
Evapotranspiration (m ³ /year)	37504	37504
Infiltration (m ³ /year)	16896	16896
Impervious Area Infiltration (m ³ /year)	0	0
Total Infiltration (m³/year)	16896	16896
Runoff Pervious Areas (m ³ /year)	9088	9088
Runoff Impervious Areas (m ³ /year)	0	0
Total Runoff (m³/year)	9088	9088
Total Outputs (m³/year)	63488	63488
Difference (Inputs - Outputs) (m³/year)	0	0

Table 2 - Water Budget - Post-Development Conditions

Under Post-Development conditions, The proposed re-development of the site will exhibit a pervious area of 51% (3.26ha) and an impervious area of 49% (3.14ha).

Catchment Designation	Site		
	Pervious	Impervious	Totals
Area (m ²)	32600	31400	64000
Pervious Area (m ²)	32600	0	32600
Impervious Area (m ²)	0	31400	31400
Impervious Factors (Per MECP Guidelines referenced by CA Guideline)			
Topography Infiltration Factor	Rolling to Hilly 0.15	Rolling to Hilly 0.15	
Soil Infiltration Factor	Sand 0.4	Sand 0.4	
Land Cover Infiltration Factor	Cleared 0.1	Impervious 0	
MOECC Infiltration Factor	0.65	0	
Actual Infiltration Factor	0.65	0	
Run-Off Coefficient	0.35	1	
Runoff from Impervious Surfaces*	0	0.8	
Inputs (per Unit Area)			
Precipitation (mm/year)	992	992	992
Run-On (mm/year)	0	0	0
Other Inputs (mm/year)	0	0	0
Total Inputs (mm/year)	992	992	992
Outputs (per Unit Area)			
Precipitation Surplus (mm/year)	406	794	596
Net Surplus (mm/year)	406	794	596
Evapotranspiration (mm/year)	586	198	396
Infiltration (mm/year)	264	0	135
Impervious Area Infiltration (mm/year)	0	0	0
Total Infiltration (mm/year)	264	0	135
Runoff Pervious Areas (mm/year)	142	0	72
Runoff Impervious Areas (mm/year)	0	794	389
Total Runoff (mm/year)	142	794	461
Total Outputs (mm/year)	992	992	992
Difference (Inputs - Outputs) (mm/year)	0	0	0

Inputs (Volume)			
Precipitation (m ³ /year)	32339	31149	63488
Run-On (m ³ /year)	0	0	0
Other Inputs (m ³ /year)	0	0	0
Total Inputs (m³/year)	32339	31149	63488
Outputs (Volume)			
Precipitation Surplus (m ³ /year)	13236	24932	38168
Net Surplus (m ³ /year)	13236	24932	38168
Evapotranspiration (m ³ /year)	19104	6217	25321
Infiltration (m ³ /year)	8606	0	8606
Impervious Area Infiltration (m ³ /year)	0	0	0
Total Infiltration (m³/year)	8606	0	8606
Runoff Pervious Areas (m ³ /year)	4629	0	4629
Runoff Impervious Areas (m ³ /year)	0	24932	24932
Total Runoff (m³/year)	4629	24932	29561
Total Outputs (m³/year)	32339	31149	63488
Difference (Inputs - Outputs) (m ³ /year)	0	0	0

Note: * Per guidelines, evaporation from impervious areas assumed to be 20% of precipitation.
 ** Minor differences attributable to rounding.

Table 3 - Water Budget - Post-Development Conditions with Mitigation

Based on the above assessment, approximately 8,290m³/year (33.3%) of the runoff from the impervious areas of the site will need to be infiltrated on the site in order to maintain the overall rate of infiltration relative to pre-development (pre-marina) conditions. The viability of infiltrating this volume of water is discussed below.

Catchment Designation	Site		
	Pervious	Impervious	Totals
Area (m ²)	32600	31400	64000
Pervious Area (m ²)	32600	0	32600
Impervious Area (m ²)	0	31400	31400
Impervious Factors (Per MECP Guidelines referenced by CA Guideline)			
Topography Infiltration Factor	Rolling to Hilly 0.15	Rolling to Hilly 0.15	
Soil Infiltration Factor	Sand 0.4	Sand 0.4	
Land Cover Infiltration Factor	Cleared 0.1	Impervious 0	
MOECC Infiltration Factor	0.65	0	
Actual Infiltration Factor	0.65	0	
Run-Off Coefficient	0.35	1	
Runoff from Impervious Surfaces*	0	0.8	
Inputs (per Unit Area)			
Precipitation (mm/year)	992	992	992
Run-On (mm/year)	0	0	0
Other Inputs (mm/year)	0	0	0
Total Inputs (mm/year)	992	992	992
Outputs (per Unit Area)			
Precipitation Surplus (mm/year)	406	794	596
Net Surplus (mm/year)	406	794	596
Evapotranspiration (mm/year)	586	198	396
Infiltration (mm/year)	264	0	135
Impervious Area Infiltration (mm/year)	0	264	129
Total Infiltration (mm/year)	264	264	264
Runoff Pervious Areas (mm/year)	142	0	72
Runoff Impervious Areas (mm/year)	0	530	259
Total Runoff (mm/year)	142	530	331
Total Outputs (mm/year)	992	992	991

Difference (Inputs - Outputs) (mm/year)	0	0	-1**
Inputs (Volume)			
Precipitation (m ³ /year)	32339	31149	63488
Run-On (m ³ /year)	0	0	0
Other Inputs (m ³ /year)	0	0	0
Total Inputs (m ³ /year)	32339	31149	63488
Outputs (Volume)			
Precipitation Surplus (m ³ /year)	13236	24932	38168
Net Surplus (m ³ /year)	13236	24932	38168
Evapotranspiration (m ³ /year)	19104	6217	25321
Infiltration (m ³ /year)	8606	0	8606
Impervious Area Infiltration (m ³ /year)	0	8290	8290
Total Infiltration (m ³ /year)	8606	8290	16896
Runoff Pervious Areas (m ³ /year)	4629	0	4629
Runoff Impervious Areas (m ³ /year)	0	16642	16642
Total Runoff (m ³ /year)	4629	16642	21271
Total Outputs (m ³ /year)	32339	31149	63488
Difference (inputs - Outputs) (m ³ /year)	0	0	0

Note: * Per guidelines, evaporation from impervious areas assumed to be 20% of precipitation.

** Minor differences attributable to rounding.

Table 4 - Water Budget Summary

Characteristic	Site				
	Current	Post-Development	% Change (Current to Post)	Post Development with Mitigation	% Change (Current to Post with Mitigation)
Inputs (Volumes)					
Precipitation (m ³ /year)	63488	63488	0	63488	0
Run-On (m ³ /year)	0	0	0	0	0
Other Inputs (m ³ /year)	0	0	0	0	0
Total Inputs (m ³ /year)	63488	63488	0	63488	0
Outputs (Volumes)					
Precipitation Surplus (m ³ /year)	25984	38168	47	38168	47
Net Surplus (m ³ /year)	25984	38168	47	38168	47
Evapotranspiration (m ³ /year)	37504	25321	-28	25321	-28
Infiltration (m ³ /year)	16896	8606	-49	8606	-49
Impervious Area Infiltration (m ³ /year)	0	0	0	8290	33.3
Total Infiltration (m ³ /year)	16896	8606	-49	16896	0
Runoff Pervious Areas (m ³ /year)	9088	4629	-49	4629	-49
Runoff Impervious Areas (m ³ /year)	0	24932	+24932 m ³ /year	16642	+16642 m ³ /year
Total Runoff (m ³ /year)	9088	29561	193	21271	115
Total Outputs (m ³ /year)	63488	63488	0	63488	0

Mitigation assumes that 33.3% of runoff from the impervious areas of the site can be infiltrated on-site, or about 8,290m³/year. It is assumed that most of this will be infiltrated into grass swales, infiltration galleries, or other equivalent Low Impact Development (LID) measures. According to the grain-size analyses for the sand deposits provided in the MTE report (attached), the predominant native soils (i.e. a silty fine sand) will exhibit a percolation rate (T-time) in the range of 10 to 12 min/cm (based on the Hazen Formula for a Unified Soil Classification "SM"), or about 1.2m/day. Conservatively assuming that the impervious area drainage of 8,290m³/year is to be infiltrated over 30 days throughout the year, approximately 276m³ of water needs to be infiltrated per day. Based on an infiltration rate of 1.2m/day, LID measures with a total site footprint of at least 230m² are required.

SUMMARY

1. The overburden in the vicinity of the site is reported to be primarily granular, with discontinuous fine-grained lenses.
2. Based on a review of the MTE borehole data, local water well records and the 2005 NSMGS, the regional watertable surface slopes westward across the site. The watertable surface is situated 0.31 to 2.9m below grade over the site, being shallower in a westwards direction.
3. The site is mapped by the NSMGS as a groundwater discharge area.
4. Shallow groundwater quality is typical of shallow groundwater in a municipally-serviced area with few indicators of urban impact. The dissolved organic carbon and manganese contents of shallow groundwater were elevated, but are not unexpected in a low-lying, groundwater discharge area. The slightly elevated TDS content of shallow groundwater appears to be naturally occurring.
5. Based on known site conditions (i.e. sandy soils, rolling to hilly relief, cleared cover), an MECP infiltration factor of 0.65 is indicated for the undeveloped site.
6. Water budget analysis indicates that the development proposal of the site will reduce overall infiltration by about 49% from pre-development (pre-marina) conditions.
7. Due to the calculated loss in overall infiltration of the development proposal in comparison to pre-development conditions, infiltration enhancement measures must be adopted to infiltrate approximately 33.3% of runoff from impervious surfaces. It is assumed that most of this will be infiltrated into grass swales, infiltration galleries, or other equivalent Low Impact Development (LID) measures. The infiltration measures need to be maintained in a low-silt condition to avoid infiltration loss over time.

Should there be any questions regarding the above information and analysis, please feel free to contact this office.

Yours sincerely,

IAN D. WILSON ASSOCIATES LIMITED

Geoffrey Rether, P.Eng.

DEVELOPMENT CONCEPT PLAN

DATE: 19.01.25

SCALE: 1:1500

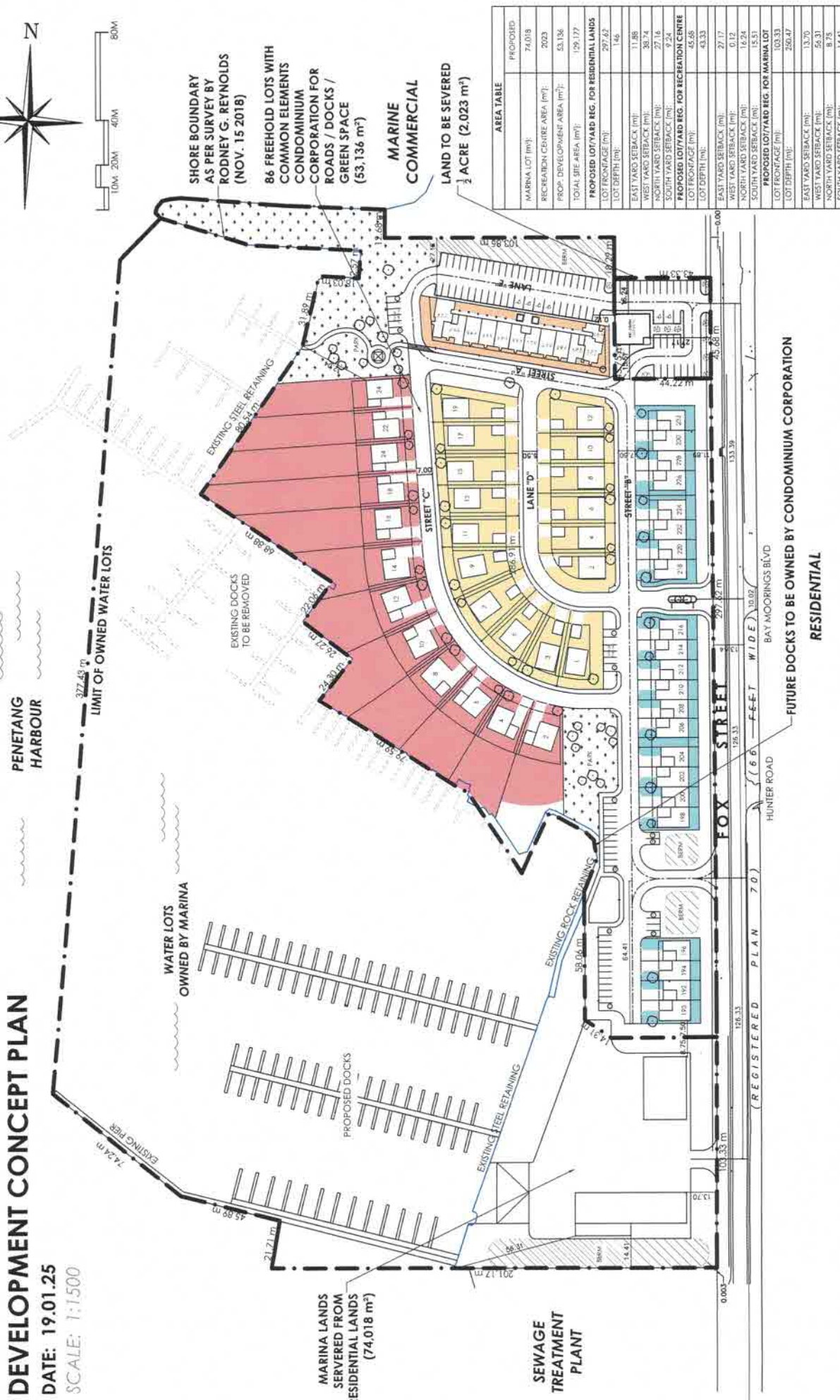
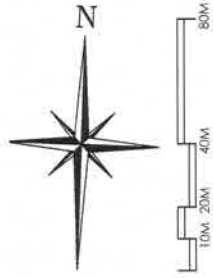

AREA TABLE	
MARINA LOT (m ²):	74,018
RECREATION CENTRE AREA (m ²):	2023
PROP. DEVELOPMENT AREA (m ²):	53,136
TOTAL SITE AREA (m ²):	129,177
PROPOSED LOT/YARD REG. FOR RESIDENTIAL LANDS	
LOT FRONTAGE (m):	297.87
LOT DEPTH (m):	146
EAST YARD SETBACK (m):	11.85
WEST YARD SETBACK (m):	38.74
NORTH YARD SETBACK (m):	27.16
SOUTH YARD SETBACK (m):	9.24
PROPOSED LOT/YARD REG. FOR RECREATION CENTRE	
LOT FRONTAGE (m):	45.65
LOT DEPTH (m):	43.33
EAST YARD SETBACK (m):	27.17
WEST YARD SETBACK (m):	0.12
NORTH YARD SETBACK (m):	16.24
SOUTH YARD SETBACK (m):	15.51
PROPOSED LOT/YARD REG. FOR MARINA LOT	
LOT FRONTAGE (m):	103.33
LOT DEPTH (m):	260.47
EAST YARD SETBACK (m):	13.70
WEST YARD SETBACK (m):	36.31
NORTH YARD SETBACK (m):	8.73
SOUTH YARD SETBACK (m):	14.41



Ontario

MINISTRY OF THE ENVIRONMENT The Ontario Water Resources Act WATER WELL RECORD

3103 W

1. PRINT ONLY IN SPACES PROVIDED
2. CHECK CORRECT BOX WHERE APPLICABLE

11 15712850

MUNICIPALITY 57606

COUNTY OR DISTRICT: Simcoe
 TOWNSHIP, BOROUGH, CITY, TOWN, VILLAGE: Penetanguishene
 CON., BLOCK, TRACT, SURVEY, ETC.: Fox Street
 DATE COMPLETED: DAY 18, MO. 09, YR. 75
 ELEVATION: 959.100, 06.00
 BASIN CODE: 22

LOG OF OVERBURDEN AND BEDROCK MATERIALS (SEE INSTRUCTIONS)

GENERAL COLOUR	MOST COMMON MATERIAL	OTHER MATERIALS	GENERAL DESCRIPTION	DEPTH - FEET	
				FROM	TO
	clay w/ sand layers			0	53
	sand		medium	53	58
	sand & gravel		cemented	58	62
	sand		coarse	62	95
	sand & gravel			95	140
	limestone			140	142

31 0053 052874 0058 09 0062 281160 0095 10 0140 28111 0142 115
 32

41 WATER RECORD

WATER FOUND AT - FEET	KIND OF WATER
0053	<input checked="" type="checkbox"/> FRESH <input type="checkbox"/> SULPHUR <input type="checkbox"/> SALTY <input type="checkbox"/> MINERAL
0062	<input checked="" type="checkbox"/> FRESH <input type="checkbox"/> SULPHUR <input type="checkbox"/> SALTY <input type="checkbox"/> MINERAL
	<input type="checkbox"/> FRESH <input type="checkbox"/> SULPHUR <input type="checkbox"/> SALTY <input type="checkbox"/> MINERAL
	<input type="checkbox"/> FRESH <input type="checkbox"/> SULPHUR <input type="checkbox"/> SALTY <input type="checkbox"/> MINERAL
	<input type="checkbox"/> FRESH <input type="checkbox"/> SULPHUR <input type="checkbox"/> SALTY <input type="checkbox"/> MINERAL

51 CASING & OPEN HOLE RECORD

DEPTH - FEET	MATERIAL	WALL THICKNESS INCHES	DEPTH - FEET	
			FROM	TO
06	<input checked="" type="checkbox"/> STEEL <input type="checkbox"/> GALVANIZED <input type="checkbox"/> CONCRETE <input type="checkbox"/> OPEN HOLE	.188	0	0112
17-18	<input type="checkbox"/> STEEL <input type="checkbox"/> GALVANIZED <input type="checkbox"/> CONCRETE <input type="checkbox"/> OPEN HOLE			20-23
24-25	<input type="checkbox"/> STEEL <input type="checkbox"/> GALVANIZED <input type="checkbox"/> CONCRETE <input type="checkbox"/> OPEN HOLE			27-30

61 PLUGGING & SEALING RECORD

DEPTH SET AT - FEET	MATERIAL AND TYPE	(CEMENT GROUT, LEAD PACKER, ETC.)
10-15	10" x mild steel	seal
16-21	16" x stainless steel	0106
26-29		

71 PUMPING TEST

PUMPING TEST METHOD	PUMPING RATE	DURATION OF PUMPING
<input checked="" type="checkbox"/> PUMP <input type="checkbox"/> BAILER	0466 GPM	48 HOURS 00 MINS
STATIC WATER LEVEL	WATER LEVELS DURING PUMPING	
66.045	043 043 044 044	
FEET 42.74	FEET 42.58 43.00 43.63 43.96	
IF FLOWING GIVE RATE	PUMP INTAKE SET AT	WATER AT END OF TEST
0060 GPM		<input checked="" type="checkbox"/> CLEAR <input type="checkbox"/> CLOUDY
RECOMMENDED PUMP TYPE	RECOMMENDED PUMP SETTING	RECOMMENDED PUMPING RATE
<input type="checkbox"/> SHALLOW <input type="checkbox"/> DEEP		

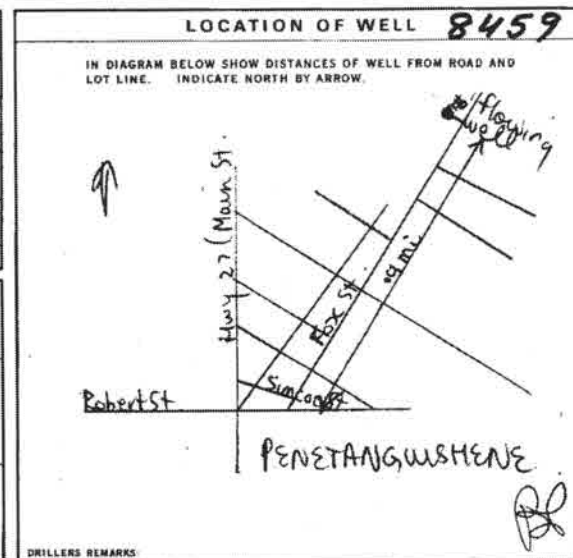

FINAL STATUS OF WELL: 2

WATER USE: 06

METHOD OF DRILLING: 2

CONTRACTOR: Snider Drilling Limited, 4816
 Address: Craighurst, Ont.
 Name of Driller or Borer: Donald Prince
 Signature of Contractor: Ralph Snider

OFFICE USE ONLY

DATA SOURCE: 1
 CONTRACTOR: 4816
 DATE RECEIVED: 240276
 DATE OF INSPECTION: Aug 11/76
 INSPECTOR: P B
 REMARKS: WI

N/A

Instructions for Completing Form

- For use in the Province of Ontario only. This document is a permanent legal document. Please retain for future reference.
- All Sections must be completed in full to avoid delays in processing. Further instructions and explanations are available on the back of this form.
- Questions regarding completing this application can be directed to the Water Well Management Coordinator at 416-235-6203.
- All metre measurements shall be reported to 1/10th of a metre.
- Please print clearly in blue or black ink only.

Ministry Use Only

Well Owner's Information and Location of Well

Location of Well (County/District/Municipality): **SIMCOE** Township: **TINY** Lot: Concession:
 RR#/Street Number/Name: **FOX ST.** City/Town/Village: **PENETANGUISHENE** Site/Compartment/Block/Tract etc.:
 GPS Reading: NAD **8.3** Zone **17** Easting **584478** Northing **4959345** Unit Make/Model: **MAGELIAN** Mode of Operation: Undifferentiated Averaged Differentiated, specify

Log of Overburden and Bedrock Materials (see instructions)

General Colour	Most common material	Other Materials	General Description	Depth From	Metres To
	- ABANDONMENT OF OLD 8" DIA. WELL KNOWN AS FOX ST. #2				
	- CUT CASING 6.1m (20 FT) BELOW GROUND LEVEL AND REMOVED				

Hole Diameter

Depth From	Metres To	Diameter Centimetres

Water Record

Water found at: m Fresh Sulphur Gas Salty Minerals Other:

After test of well yield, water was Clear and sediment free Other, specify:

Chlorinated Yes No

Construction Record

Inside diam centimetres	Material	Wall thickness centimetres	Depth From	Metres To
Casing				
	<input type="checkbox"/> Steel <input type="checkbox"/> Fibreglass <input type="checkbox"/> Plastic <input type="checkbox"/> Concrete <input type="checkbox"/> Galvanized			
Screen				
Outside diam	<input type="checkbox"/> Steel <input type="checkbox"/> Fibreglass <input type="checkbox"/> Plastic <input type="checkbox"/> Concrete <input type="checkbox"/> Galvanized	Slot No.		
No Casing or Screen				
<input type="checkbox"/> Open hole				

Test of Well Yield

Pumping test method	Draw Down		Recovery	
	Time min	Water Level Metres	Time min	Water Level Metres
Pump intake set at - (metres)	Static Level			
Pumping rate - (litres/min)	1		1	
Duration of pumping hrs + min	2		2	
Final water level end of pumping metres	3		3	
Recommended pump type	4		4	
Recommended pump depth metres	5		5	
Recommended pump rate (litres/min)	10		10	
If flowing give rate - (litres/min)	15		15	
	20		20	
	25		25	
If pumping discontinued, give reason.	30		30	
	40		40	
	50		50	
	60		60	

Plugging and Sealing Record Annular space Abandonment

Depth set at - Metres From	To	Material and type (bentonite slurry, neat cement slurry) etc.	Volume Placed (cubic metres)
43.1	0	BENTONITE	1.3

Method of Construction

Cable Tool Rotary (air) Diamond Digging Rotary (conventional) Air percussion Jetting Other Rotary (reverse) Boring Driving

Water Use

Domestic Industrial Public Supply Other Stock Commercial Not used Irrigation Municipal Cooling & air conditioning

Final Status of Well

Water Supply Recharge well Unfinished Abandoned, (Other) Observation well Abandoned, insufficient supply Dewatering Test Hole Abandoned, poor quality Replacement well

Well Contractor/Technician Information

Name of Well Contractor: **INTERNATIONAL WATER SUPPLY** Well Contractor's Licence No.: **2801**
 Business Address (street name, number, city etc.): **PO BOX 310 BARRIE ON L4M4T5**
 Name of Well Technician (last name, first name): **WALTER NOBES** Well Technician's Licence No.: **10115**
 Signature of Technician/Contractor: *[Signature]* Date Submitted: **2006/12/04**

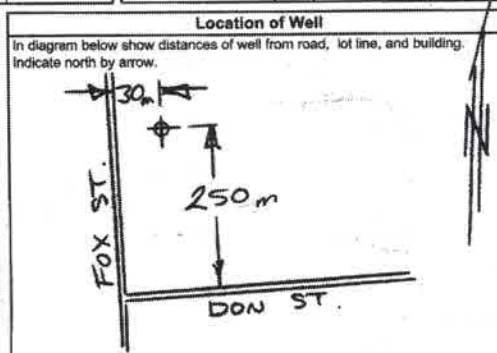

Audit No. **z 33272** Date Well Completed **2006/12/04**
 Was the well owner's information package delivered? Yes No

Ministry Use Only

Data Source: Contractor **2801**
 Date Received: **JAN 25 2007** Date of Inspection: **2006/12/04**
 Remarks: Wall Record Number

Your Project #: MOORINGS
Your C.O.C. #: 12478

Attention: Geoff Rether

Ian D Wilson Associates Ltd
PO Box 299
76722 Airport Rd
Clinton, ON
CANADA NOM 1L0

Report Date: 2018/06/21
Report #: R5260835
Version: 1 - Final

CERTIFICATE OF ANALYSIS

MAXXAM JOB #: B8E7265

Received: 2018/06/15, 10:30

Sample Matrix: Water
Samples Received: 1

Analyses	Quantity	Date Extracted	Date Analyzed	Laboratory Method	Reference
Alkalinity	1	N/A	2018/06/20	CAM SOP-00448	SM 23 2320 B m
Carbonate, Bicarbonate and Hydroxide	1	N/A	2018/06/21	CAM SOP-00102	APHA 4500-CO2 D
Chloride by Automated Colourimetry	1	N/A	2018/06/19	CAM SOP-00463	EPA 325.2 m
Conductivity	1	N/A	2018/06/20	CAM SOP-00414	SM 23 2510 m
Dissolved Organic Carbon (DOC) (1)	1	N/A	2018/06/19	CAM SOP-00446	SM 23 5310 B m
Hardness (calculated as CaCO3)	1	N/A	2018/06/21	CAM SOP 00102/00408/00447	SM 2340 B
Lab Filtered Metals by ICPMS	1	2018/06/19	2018/06/20	CAM SOP-00447	EPA 6020B m
Ion Balance (% Difference)	1	N/A	2018/06/21		
Anion and Cation Sum	1	N/A	2018/06/21		
Total Ammonia-N	1	N/A	2018/06/19	CAM SOP-00441	EPA GS I-2522-90 m
Nitrate (NO3) and Nitrite (NO2) in Water (2)	1	N/A	2018/06/19	CAM SOP-00440	SM 23 4500-NO3I/NO2B
pH	1	N/A	2018/06/20	CAM SOP-00413	SM 4500H+ B m
Orthophosphate	1	N/A	2018/06/19	CAM SOP-00461	EPA 365.1 m
Sat. pH and Langelier Index (@ 20C)	1	N/A	2018/06/21		
Sat. pH and Langelier Index (@ 4C)	1	N/A	2018/06/21		
Sulphate by Automated Colourimetry	1	N/A	2018/06/19	CAM SOP-00464	EPA 375.4 m
Total Dissolved Solids (TDS calc)	1	N/A	2018/06/21		

Remarks:

Maxxam Analytics' laboratories are accredited to ISO/IEC 17025:2005 for specific parameters on scopes of accreditation. Unless otherwise noted, procedures used by Maxxam are based upon recognized Provincial, Federal or US method compendia such as CCME, MDDELCC, EPA, APHA.

All work recorded herein has been done in accordance with procedures and practices ordinarily exercised by professionals in Maxxam's profession using accepted testing methodologies, quality assurance and quality control procedures (except where otherwise agreed by the client and Maxxam in writing). All data is in statistical control and has met quality control and method performance criteria unless otherwise noted. All method blanks are reported; unless indicated otherwise, associated sample data are not blank corrected.

Maxxam Analytics' liability is limited to the actual cost of the requested analyses, unless otherwise agreed in writing. There is no other warranty expressed or implied. Maxxam has been retained to provide analysis of samples provided by the Client using the testing methodology referenced in this report. Interpretation and use of test results are the sole responsibility of the Client and are not within the scope of services provided by Maxxam, unless otherwise agreed in writing.

Your Project #: MOORINGS
Your C.O.C. #: 12478

Attention: Geoff Rether

Ian D Wilson Associates Ltd
PO Box 299
76722 Airport Rd
Clinton, ON
CANADA N0M 1L0

Report Date: 2018/06/21
Report #: R5260835
Version: 1 - Final

CERTIFICATE OF ANALYSIS

MAXXAM JOB #: B8E7265

Received: 2018/06/15, 10:30

Solid sample results, except biota, are based on dry weight unless otherwise indicated. Organic analyses are not recovery corrected except for isotope dilution methods.

Results relate to samples tested.

This Certificate shall not be reproduced except in full, without the written approval of the laboratory.

Reference Method suffix "m" indicates test methods incorporate validated modifications from specific reference methods to improve performance.

* RPDs calculated using raw data. The rounding of final results may result in the apparent difference.

(1) Dissolved Organic Carbon (DOC) present in the sample should be considered as non-purgeable DOC.

(2) Values for calculated parameters may not appear to add up due to rounding of raw data and significant figures.

Encryption Key



Ashton Gibson
Project Manager
22 Jun 2018 15:57:09

Please direct all questions regarding this Certificate of Analysis to your Project Manager.

Ashton Gibson, Project Manager

Email: AGibson@maxxam.ca

Phone# (905) 817-5700

=====

Maxxam has procedures in place to guard against improper use of the electronic signature and have the required "signatories", as per section 5.10.2 of ISO/IEC 17025:2005(E), signing the reports. For Service Group specific validation please refer to the Validation Signature Page.

RCAP - COMPREHENSIVE (LAB FILTERED)

Maxxam ID		GZA031		
Sampling Date		2018/06/14 14:30		
COC Number		12478		
	UNITS	BH 202-18	RDL	QC Batch
Calculated Parameters				
Anion Sum	me/L	10.8	N/A	5584342
Bicarb. Alkalinity (calc. as CaCO3)	mg/L	500	1.0	5584337
Calculated TDS	mg/L	550	1.0	5584345
Carb. Alkalinity (calc. as CaCO3)	mg/L	2.8	1.0	5584337
Cation Sum	me/L	10.7	N/A	5584342
Hardness (CaCO3)	mg/L	480	1.0	5584340
Ion Balance (% Difference)	%	0.550	N/A	5584341
Langelier Index (@ 20C)	N/A	1.18		5584343
Langelier Index (@ 4C)	N/A	0.935		5584344
Saturation pH (@ 20C)	N/A	6.59		5584343
Saturation pH (@ 4C)	N/A	6.84		5584344
Inorganics				
Total Ammonia-N	mg/L	1.8	0.050	5585860
Conductivity	umho/cm	940	1.0	5586187
Dissolved Organic Carbon	mg/L	8.4	0.50	5586628
Orthophosphate (P)	mg/L	0.024	0.010	5586666
pH	pH	7.77		5586188
Dissolved Sulphate (SO4)	mg/L	10	1.0	5586665
Alkalinity (Total as CaCO3)	mg/L	500	1.0	5586184
Dissolved Chloride (Cl)	mg/L	19	1.0	5586663
Nitrite (N)	mg/L	ND	0.010	5586249
Nitrate (N)	mg/L	ND	0.10	5586249
Metals				
Dissolved Aluminum (Al)	ug/L	6.9	5.0	5588028
Dissolved Antimony (Sb)	ug/L	ND	0.50	5588028
Dissolved Arsenic (As)	ug/L	ND	1.0	5588028
Dissolved Barium (Ba)	ug/L	220	2.0	5588028
Dissolved Beryllium (Be)	ug/L	ND	0.50	5588028
Dissolved Boron (B)	ug/L	66	10	5588028
Dissolved Cadmium (Cd)	ug/L	ND	0.10	5588028
Dissolved Calcium (Ca)	ug/L	150000	200	5588028
Dissolved Chromium (Cr)	ug/L	5.9	5.0	5588028
Dissolved Cobalt (Co)	ug/L	1.1	0.50	5588028
RDL = Reportable Detection Limit QC Batch = Quality Control Batch N/A = Not Applicable ND = Not detected				

RCAP - COMPREHENSIVE (LAB FILTERED)

Maxxam ID		GZA031		
Sampling Date		2018/06/14 14:30		
COC Number		12478		
	UNITS	BH 202-18	RDL	QC Batch
Dissolved Copper (Cu)	ug/L	1.8	1.0	5588028
Dissolved Iron (Fe)	ug/L	ND	100	5588028
Dissolved Lead (Pb)	ug/L	ND	0.50	5588028
Dissolved Magnesium (Mg)	ug/L	23000	50	5588028
Dissolved Manganese (Mn)	ug/L	1400	2.0	5588028
Dissolved Molybdenum (Mo)	ug/L	2.3	0.50	5588028
Dissolved Nickel (Ni)	ug/L	1.7	1.0	5588028
Dissolved Phosphorus (P)	ug/L	ND	100	5588028
Dissolved Potassium (K)	ug/L	2700	200	5588028
Dissolved Selenium (Se)	ug/L	ND	2.0	5588028
Dissolved Silicon (Si)	ug/L	8200	50	5588028
Dissolved Silver (Ag)	ug/L	ND	0.10	5588028
Dissolved Sodium (Na)	ug/L	20000	100	5588028
Dissolved Strontium (Sr)	ug/L	590	1.0	5588028
Dissolved Thallium (Tl)	ug/L	ND	0.050	5588028
Dissolved Titanium (Ti)	ug/L	ND	5.0	5588028
Dissolved Uranium (U)	ug/L	2.0	0.10	5588028
Dissolved Vanadium (V)	ug/L	1.3	0.50	5588028
Dissolved Zinc (Zn)	ug/L	ND	5.0	5588028
RDL = Reportable Detection Limit QC Batch = Quality Control Batch ND = Not detected				

TEST SUMMARY

Maxxam ID: GZA031
Sample ID: BH 202-18
Matrix: Water

Collected: 2018/06/14
Shipped:
Received: 2018/06/15

Test Description	Instrumentation	Batch	Extracted	Date Analyzed	Analyst
Alkalinity	AT	5586184	N/A	2018/06/20	Surinder Rai
Carbonate, Bicarbonate and Hydroxide	CALC	5584337	N/A	2018/06/21	Automated Statchk
Chloride by Automated Colourimetry	KONE	5586663	N/A	2018/06/19	Deonarine Ramnarine
Conductivity	AT	5586187	N/A	2018/06/20	Surinder Rai
Dissolved Organic Carbon (DOC)	TOCV/NDIR	5586628	N/A	2018/06/19	Nimarta Singh
Hardness (calculated as CaCO3)		5584340	N/A	2018/06/21	Automated Statchk
Lab Filtered Metals by ICPMS	ICP/MS	5588028	2018/06/19	2018/06/20	Thao Nguyen
Ion Balance (% Difference)	CALC	5584341	N/A	2018/06/21	Automated Statchk
Anion and Cation Sum	CALC	5584342	N/A	2018/06/21	Automated Statchk
Total Ammonia-N	LACH/NH4	5585860	N/A	2018/06/19	Parminder Sangha
Nitrate (NO3) and Nitrite (NO2) in Water	LACH	5586249	N/A	2018/06/19	Chandra Nandlal
pH	AT	5586188	N/A	2018/06/20	Surinder Rai
Orthophosphate	KONE	5586666	N/A	2018/06/19	Alina Dobreanu
Sat. pH and Langelier Index (@ 20C)	CALC	5584343	N/A	2018/06/21	Automated Statchk
Sat. pH and Langelier Index (@ 4C)	CALC	5584344	N/A	2018/06/21	Automated Statchk
Sulphate by Automated Colourimetry	KONE	5586665	N/A	2018/06/19	Alina Dobreanu
Total Dissolved Solids (TDS calc)	CALC	5584345	N/A	2018/06/21	Automated Statchk

GENERAL COMMENTS

The following sediment comments applies to sample BH202-18

All of the 500mL plastic General and Solids bottles contained visible sediment.
All of the 250mL plastic bottles for NH4LOW analysis contained visible sediment.

Sample GZA031 [BH 202-18] : ortho-Phosphate > Total Phosphorus: Both values fall within the method uncertainty for duplicates and are likely equivalent.

Results relate only to the items tested.

QUALITY ASSURANCE REPORT

QA/QC Batch	Init	QC Type	Parameter	Date Analyzed	Value	Recovery	UNITS	QC Limits
5585860	SAN	Matrix Spike	Total Ammonia-N	2018/06/19		98	%	75 - 125
5585860	SAN	Spiked Blank	Total Ammonia-N	2018/06/19		103	%	80 - 120
5585860	SAN	Method Blank	Total Ammonia-N	2018/06/19	ND, RDL=0.050		mg/L	
5585860	SAN	RPD	Total Ammonia-N	2018/06/19	3.9		%	20
5586184	SAU	Spiked Blank	Alkalinity (Total as CaCO3)	2018/06/20		96	%	85 - 115
5586184	SAU	Method Blank	Alkalinity (Total as CaCO3)	2018/06/20	ND, RDL=1.0		mg/L	
5586184	SAU	RPD	Alkalinity (Total as CaCO3)	2018/06/20	0.81		%	20
5586187	SAU	Spiked Blank	Conductivity	2018/06/20		101	%	85 - 115
5586187	SAU	Method Blank	Conductivity	2018/06/20	ND, RDL=1.0		umho/cm	
5586187	SAU	RPD	Conductivity	2018/06/20	0.33		%	25
5586188	SAU	Spiked Blank	pH	2018/06/20		102	%	98 - 103
5586188	SAU	RPD	pH	2018/06/20	0.26		%	N/A
5586249	C_N	Matrix Spike	Nitrite (N)	2018/06/19		98	%	80 - 120
			Nitrate (N)	2018/06/19		92	%	80 - 120
5586249	C_N	Spiked Blank	Nitrite (N)	2018/06/19		98	%	80 - 120
			Nitrate (N)	2018/06/19		93	%	80 - 120
5586249	C_N	Method Blank	Nitrite (N)	2018/06/19	ND, RDL=0.010		mg/L	
			Nitrate (N)	2018/06/19	ND, RDL=0.10		mg/L	
5586249	C_N	RPD	Nitrate (N)	2018/06/19	NC		%	20
5586628	NS3	Matrix Spike	Dissolved Organic Carbon	2018/06/19		97	%	80 - 120
5586628	NS3	Spiked Blank	Dissolved Organic Carbon	2018/06/19		98	%	80 - 120
5586628	NS3	Method Blank	Dissolved Organic Carbon	2018/06/19	ND, RDL=0.50		mg/L	
5586628	NS3	RPD	Dissolved Organic Carbon	2018/06/19	4.5		%	20
5586663	DRM	Matrix Spike	Dissolved Chloride (Cl)	2018/06/19		86	%	80 - 120
5586663	DRM	Spiked Blank	Dissolved Chloride (Cl)	2018/06/19		104	%	80 - 120
5586663	DRM	Method Blank	Dissolved Chloride (Cl)	2018/06/19	ND, RDL=1.0		mg/L	
5586663	DRM	RPD	Dissolved Chloride (Cl)	2018/06/19	0.023		%	20
5586665	ADB	Matrix Spike	Dissolved Sulphate (SO4)	2018/06/19		107	%	75 - 125
5586665	ADB	Spiked Blank	Dissolved Sulphate (SO4)	2018/06/19		100	%	80 - 120
5586665	ADB	Method Blank	Dissolved Sulphate (SO4)	2018/06/19	ND, RDL=1.0		mg/L	
5586665	ADB	RPD	Dissolved Sulphate (SO4)	2018/06/19	NC		%	20
5586666	ADB	Matrix Spike	Orthophosphate (P)	2018/06/19		101	%	75 - 125
5586666	ADB	Spiked Blank	Orthophosphate (P)	2018/06/19		100	%	80 - 120
5586666	ADB	Method Blank	Orthophosphate (P)	2018/06/19	ND, RDL=0.010		mg/L	
5586666	ADB	RPD	Orthophosphate (P)	2018/06/19	NC		%	25
5588028	TNG	Matrix Spike	Dissolved Aluminum (Al)	2018/06/20		92	%	80 - 120
			Dissolved Antimony (Sb)	2018/06/20		96	%	80 - 120
			Dissolved Arsenic (As)	2018/06/20		91	%	80 - 120
			Dissolved Barium (Ba)	2018/06/20		92	%	80 - 120
			Dissolved Beryllium (Be)	2018/06/20		93	%	80 - 120
			Dissolved Boron (B)	2018/06/20		96	%	80 - 120
			Dissolved Cadmium (Cd)	2018/06/20		93	%	80 - 120
			Dissolved Calcium (Ca)	2018/06/20		NC	%	80 - 120
			Dissolved Chromium (Cr)	2018/06/20		91	%	80 - 120
			Dissolved Cobalt (Co)	2018/06/20		91	%	80 - 120
			Dissolved Copper (Cu)	2018/06/20		92	%	80 - 120

QUALITY ASSURANCE REPORT(CONT'D)

QA/QC Batch	Init	QC Type	Parameter	Date Analyzed	Value	Recovery	UNITS	QC Limits
			Dissolved Iron (Fe)	2018/06/20		92	%	80 - 120
			Dissolved Lead (Pb)	2018/06/20		89	%	80 - 120
			Dissolved Magnesium (Mg)	2018/06/20		90	%	80 - 120
			Dissolved Manganese (Mn)	2018/06/20		92	%	80 - 120
			Dissolved Molybdenum (Mo)	2018/06/20		95	%	80 - 120
			Dissolved Nickel (Ni)	2018/06/20		90	%	80 - 120
			Dissolved Phosphorus (P)	2018/06/20		99	%	80 - 120
			Dissolved Potassium (K)	2018/06/20		94	%	80 - 120
			Dissolved Selenium (Se)	2018/06/20		95	%	80 - 120
			Dissolved Silicon (Si)	2018/06/20		92	%	80 - 120
			Dissolved Silver (Ag)	2018/06/20		83	%	80 - 120
			Dissolved Sodium (Na)	2018/06/20		NC	%	80 - 120
			Dissolved Strontium (Sr)	2018/06/20		91	%	80 - 120
			Dissolved Thallium (Tl)	2018/06/20		90	%	80 - 120
			Dissolved Titanium (Ti)	2018/06/20		93	%	80 - 120
			Dissolved Uranium (U)	2018/06/20		89	%	80 - 120
			Dissolved Vanadium (V)	2018/06/20		93	%	80 - 120
			Dissolved Zinc (Zn)	2018/06/20		92	%	80 - 120
5588028	TNG	Spiked Blank	Dissolved Aluminum (Al)	2018/06/20		101	%	80 - 120
			Dissolved Antimony (Sb)	2018/06/20		104	%	80 - 120
			Dissolved Arsenic (As)	2018/06/20		97	%	80 - 120
			Dissolved Barium (Ba)	2018/06/20		100	%	80 - 120
			Dissolved Beryllium (Be)	2018/06/20		101	%	80 - 120
			Dissolved Boron (B)	2018/06/20		102	%	80 - 120
			Dissolved Cadmium (Cd)	2018/06/20		101	%	80 - 120
			Dissolved Calcium (Ca)	2018/06/20		101	%	80 - 120
			Dissolved Chromium (Cr)	2018/06/20		98	%	80 - 120
			Dissolved Cobalt (Co)	2018/06/20		98	%	80 - 120
			Dissolved Copper (Cu)	2018/06/20		102	%	80 - 120
			Dissolved Iron (Fe)	2018/06/20		100	%	80 - 120
			Dissolved Lead (Pb)	2018/06/20		98	%	80 - 120
			Dissolved Magnesium (Mg)	2018/06/20		98	%	80 - 120
			Dissolved Manganese (Mn)	2018/06/20		99	%	80 - 120
			Dissolved Molybdenum (Mo)	2018/06/20		102	%	80 - 120
			Dissolved Nickel (Ni)	2018/06/20		98	%	80 - 120
			Dissolved Phosphorus (P)	2018/06/20		118	%	80 - 120
			Dissolved Potassium (K)	2018/06/20		99	%	80 - 120
			Dissolved Selenium (Se)	2018/06/20		102	%	80 - 120
			Dissolved Silicon (Si)	2018/06/20		99	%	80 - 120
			Dissolved Silver (Ag)	2018/06/20		100	%	80 - 120
			Dissolved Sodium (Na)	2018/06/20		99	%	80 - 120
			Dissolved Strontium (Sr)	2018/06/20		98	%	80 - 120
			Dissolved Thallium (Tl)	2018/06/20		97	%	80 - 120
			Dissolved Titanium (Ti)	2018/06/20		101	%	80 - 120
			Dissolved Uranium (U)	2018/06/20		99	%	80 - 120
			Dissolved Vanadium (V)	2018/06/20		100	%	80 - 120
			Dissolved Zinc (Zn)	2018/06/20		99	%	80 - 120
5588028	TNG	Method Blank	Dissolved Aluminum (Al)	2018/06/20	ND, RDL=5.0		ug/L	
			Dissolved Antimony (Sb)	2018/06/20	ND, RDL=0.50		ug/L	
			Dissolved Arsenic (As)	2018/06/20	ND, RDL=1.0		ug/L	
			Dissolved Barium (Ba)	2018/06/20	ND, RDL=2.0		ug/L	

QUALITY ASSURANCE REPORT(CONT'D)

QA/QC Batch	Init	QC Type	Parameter	Date Analyzed	Value	Recovery	UNITS	QC Limits
			Dissolved Beryllium (Be)	2018/06/20	ND, RDL=0.50		ug/L	
			Dissolved Boron (B)	2018/06/20	ND, RDL=10		ug/L	
			Dissolved Cadmium (Cd)	2018/06/20	ND, RDL=0.10		ug/L	
			Dissolved Calcium (Ca)	2018/06/20	ND, RDL=200		ug/L	
			Dissolved Chromium (Cr)	2018/06/20	ND, RDL=5.0		ug/L	
			Dissolved Cobalt (Co)	2018/06/20	ND, RDL=0.50		ug/L	
			Dissolved Copper (Cu)	2018/06/20	ND, RDL=1.0		ug/L	
			Dissolved Iron (Fe)	2018/06/20	ND, RDL=100		ug/L	
			Dissolved Lead (Pb)	2018/06/20	ND, RDL=0.50		ug/L	
			Dissolved Magnesium (Mg)	2018/06/20	ND, RDL=50		ug/L	
			Dissolved Manganese (Mn)	2018/06/20	ND, RDL=2.0		ug/L	
			Dissolved Molybdenum (Mo)	2018/06/20	ND, RDL=0.50		ug/L	
			Dissolved Nickel (Ni)	2018/06/20	ND, RDL=1.0		ug/L	
			Dissolved Phosphorus (P)	2018/06/20	ND, RDL=100		ug/L	
			Dissolved Potassium (K)	2018/06/20	ND, RDL=200		ug/L	
			Dissolved Selenium (Se)	2018/06/20	ND, RDL=2.0		ug/L	
			Dissolved Silicon (Si)	2018/06/20	ND, RDL=50		ug/L	
			Dissolved Silver (Ag)	2018/06/20	ND, RDL=0.10		ug/L	
			Dissolved Sodium (Na)	2018/06/20	ND, RDL=100		ug/L	
			Dissolved Strontium (Sr)	2018/06/20	ND, RDL=1.0		ug/L	
			Dissolved Thallium (Tl)	2018/06/20	ND, RDL=0.050		ug/L	
			Dissolved Titanium (Ti)	2018/06/20	ND, RDL=5.0		ug/L	
			Dissolved Uranium (U)	2018/06/20	ND, RDL=0.10		ug/L	
			Dissolved Vanadium (V)	2018/06/20	ND, RDL=0.50		ug/L	
			Dissolved Zinc (Zn)	2018/06/20	ND, RDL=5.0		ug/L	

QUALITY ASSURANCE REPORT(CONT'D)

QA/QC	Batch	Init	QC Type	Parameter	Date Analyzed	Value	Recovery	UNITS	QC Limits
	5588028	TNG	RPD	Dissolved Lead (Pb)	2018/06/20	NC		%	20

N/A = Not Applicable

Duplicate: Paired analysis of a separate portion of the same sample. Used to evaluate the variance in the measurement.

Matrix Spike: A sample to which a known amount of the analyte of interest has been added. Used to evaluate sample matrix interference.

Spiked Blank: A blank matrix sample to which a known amount of the analyte, usually from a second source, has been added. Used to evaluate method accuracy.

Method Blank: A blank matrix containing all reagents used in the analytical procedure. Used to identify laboratory contamination.

NC (Matrix Spike): The recovery in the matrix spike was not calculated. The relative difference between the concentration in the parent sample and the spike amount was too small to permit a reliable recovery calculation (matrix spike concentration was less than the native sample concentration)

NC (Duplicate RPD): The duplicate RPD was not calculated. The concentration in the sample and/or duplicate was too low to permit a reliable RPD calculation (absolute difference $\leq 2x$ RDL).

VALIDATION SIGNATURE PAGE

The analytical data and all QC contained in this report were reviewed and validated by the following individual(s).

Cristina Carriere

Cristina Carriere, Scientific Service Specialist

Maxxam has procedures in place to guard against improper use of the electronic signature and have the required "signatories", as per section 5.10.2 of ISO/IEC 17025:2005(E), signing the reports. For Service Group specific validation please refer to the Validation Signature Page.



FOX STREET PENETANGUISHENE PROPOSED DEVELOPMENT

Geotechnical Investigation

Project Location:
160 - 200 Fox Street
Penetanguishene, ON

Prepared for:
Wilmington Capital Management Inc.
505 3rd Street SW, Suite 700
Calgary, AB

Prepared by:
MTE Consultants Inc.
365 Home Street
Stratford, ON N5A 2A5

May 8, 2018

MTE File No.: 43022-100



APPENDICES

APPENDIX A	FIGURES
APPENDIX B	BOREHOLE LOGS
APPENDIX C	LABORATORY TEST RESULTS
APPENDIX D	TENSAR INTERNATIONAL CORPORATION PRODUCT INFORMATION
APPENDIX E	EBS GEOSTRUCTURAL INC. HELICAL PILE INFORMATION

DRAFT

1.0 INTRODUCTION

MTE Consultants Inc. (MTE) was retained by Wilmington Capital Management Inc. to conduct a geotechnical investigation for a proposed development at Municipal Numbers 160 to 200 along Fox Street in Penetanguishene, Ontario. The site is located west of Fox Street, as shown on **Figure 1 in Appendix A**. The development will involve 60 total units including 28 single detached residential buildings, 6 semi-detached residential buildings, and 26 townhomes, as per the Travis and Associates Incorporated Site Plan SP-3, dated March 2018. It is noted a future recreation centre is planned for the northeast corner of the site and additional investigation is recommended in this area once design details are known.

The site is currently the Bay Moorings Marina with numerous storage buildings and asphalt covered areas for boat storage. The site is bordered to the north by Dutchman's Cove Marina and Boat Rentals; to the east by Fox Street and a residential subdivision; to the south by residential buildings; and to the west by Penetang Harbour. The site generally slopes down from east to west approximately 4.5 m between borehole locations.

The purpose of this geotechnical investigation is to determine the soil and groundwater conditions in the area of the proposed residential development and provide geotechnical engineering recommendations for site grading, site servicing, foundations, concrete slab-on-grade, pavement design, subdrainage requirements, and stormwater infiltration.

2.0 CONCURRENT WORK

MTE conducted a due diligence Phase 2 ESA on October 16, 2017, File No. 43022-100, and is currently conducting a Phase 2 ESA and Record of Site Condition environmental investigation at the site. Environmental technicians were onsite directing the drilling and sampling during the fieldwork.

3.0 FIELD AND LABORATORY PROGRAM

The fieldwork for this investigation was carried out on March 26th, April 9th and April 10th, 2018 and involved the drilling of twenty boreholes (Boreholes BH201-18 to BH220-18) to depths ranging from 1.5 to 8.2 m. The locations of the boreholes are shown on the Site Plan, **Figure 2 in Appendix A**.

Private and public utility companies were contacted prior to the start of drilling activities in order to isolate underground utilities near the boring locations.

The boreholes were advanced with a Geoprobe 7822DT track mounted drill rig equipped with continuous flight hollow stem augers and direct push equipment, supplied and operated by Direct Environmental Drilling Inc.

Boreholes MW202-18 and BH216-18 to BH220-18 were advanced with hollow stem augers for geotechnical data and sample collection, while Boreholes BH201-18 and MW203-18 to BH215-18 were advanced using direct push equipment for environmental sample collection.

Representative soil samples were recovered throughout the depths explored. Standard Penetration Tests (SPT) were carried out during sampling operations in Boreholes MW202-18 and BH216-18 to BH220-18 using conventional split spoon equipment. The SPT N-values recorded are plotted on the borehole logs in **Appendix B**.

Samples of the cohesive soil samples were tested using a pocket penetrometer, in Boreholes MW202-18 and BH216-18 to BH220-18, respectively, to determine approximate shear strengths. The results of the penetrometer testing are plotted on the appended borehole logs.

A 50 mm diameter monitoring well and a 19 mm diameter monitoring well were installed in Boreholes MW202-18 and MW203-18 to allow measurement of the stabilized groundwater levels and groundwater sampling and testing. The installation comprised of a 3.0 m filtered screen and a bentonite seal above the screen. Details of the installation and groundwater observations and measurements are provided on the appended borehole logs.

The monitoring wells were installed in accordance to Ontario Regulation 903, as amended. A licensed well technician must properly decommission all wells before construction. The construction, maintenance and abandonment of the wells are regulated under the province's Water Resources Act.

Upon completion of drilling, the boreholes were backfilled with soil cuttings and bentonite in accordance with Ontario Regulation 468/10 (formerly O. Reg. 903) under the provinces Water Resources Act.

The fieldwork was monitored throughout by members of our geotechnical and environmental engineering staff, who directed the drilling procedures; conducted SPT tests; documented the soil stratigraphies; monitored the groundwater conditions; installed the monitoring wells; and transported the recovered soil samples back to our office for further classification.

The ground surface elevations at the borehole locations were surveyed by MTE by use of a Trimble survey device and tied into geodetic elevations.

Soil samples collected were submitted for moisture content testing. Geotechnical laboratory testing comprised of five soil samples submitted for particle size distribution analyses, one soil sample for grain size distribution analysis, and two samples for Atterberg Limits tests. The results of the laboratory tests are provided in **Appendix C**. The remaining soil samples will be stored for a period of 1 month and will be discarded of at that time without prior request from the client to extend storage time.

4.0 SOIL CONDITIONS

Reference is provided to the appended borehole logs for soil stratigraphy details, SPT N-values, results of pocket penetrometer testing, moisture content profiles, and groundwater observations and measurements. Soil conditions encountered at the site typically include asphaltic concrete and/or fill overlying native sand, silt, and clay deposits.

4.1 Asphaltic Concrete and Fill

Three of the boreholes (Boreholes MW202-18, BH216-18 and BH218-18) were drilled within the existing parking and driveway areas and encountered 50 to 100 mm of asphaltic concrete overlying fill.

Fill was encountered surficially or beneath the asphaltic concrete in all of the boreholes and is 0.1 to 4.0 m thick (average thickness = 1.9 m). The fill ranges in composition from brown silty sand and gravel to grey clayey silt. It is noted organics (topsoil) was contacted within the fill at Boreholes BH205-18, BH206-18, BH209-18, BH210-18, BH211-18, BH212-18, BH217-18, BH219-18 and BH220-18 and organic content (rootlets, peat and wood fragments) were contacted within the fill in all of the boreholes except Boreholes BH201-18, BH204-18, BH207-18 and BH216-18. Brick fragments, Styrofoam pieces and large cobbles were contacted in Boreholes BH219-18, BH207-18 and BH216-18, respectively. SPT N-values in the fill range from 1 to 46 blows per 300 mm penetration of the split spoon sampler indicating a very loose to dense relative density.

In situ moisture contents in the fill range from 5 to 40% indicating moist to saturated conditions.

4.2 Silt / Silt and Clay

Silt was encountered underlying the fill and/or sand in Boreholes BH201-18, MW202-18, MW203-18, BH204-18, BH210-18, BH212-18, BH213-18, BH215-18, BH218-18, BH219-18 and BH220-18. The silt and clay was 0.6 to 2.3 m thick and continues to the termination depth of Boreholes BH201-18, BH210-18, BH212-18 and BH213-18. The silt ranges in composition from brown sandy silt to grey clay and silt with trace sand. The results of three particle size distribution analyses conducted on samples of the silt and clay are provided in **Appendix C** and summarized in the following table;

TABLE 1 - RESULTS OF SILT AND CLAY PARTICLE SIZE DISTRIBUTION ANALYSES

Borehole Number	Sample Depth (m)	Sand (%)	Silt (%)	Clay (%)
MW202-18	3.05-3.66	1	52	47
BH216-18	2.29-2.90	29	66	5
BH219-18	1.52-2.13	5	44	51

The SPT N-values in the silt range from 0 to 6 blows per 300 mm penetration of the split spoon sampler indicating a very loose to loose relative density. Shear strength measured in the cohesive deposits of the silt and clay ranges from was 25 to 100 kPa using a pocket penetrometer.

Two samples of the silt and clay were submitted for Atterberg Limits tests and the results summarized in the following table;

TABLE 2 - RESULTS OF SILT AND CLAY ATTERBERG LIMITS TESTS

Borehole Number	Sample Depth (m)	Moisture Content (%)	Liquid Limit (LL)	Plastic Limit (PL)	Plasticity Index (PI)	Liquidity Index (LI)
MW202-18	1.52-2.13	21	25	14	11	0.63
BH219-18	1.52-2.13	40	47	22	25	-0.28

Atterberg limits test results indicate the silt and clay has a medium degree of plasticity.

In situ moisture contents in the silt range from 21 to 40% indicating wet to saturated or drier than the plastic limit (DTPL) to wetter than the plastic limit (WTPL) conditions.

4.3 Sand

Sand was encountered beneath the fill and/or silt and clay in all of the boreholes except for Boreholes BH210-18 and BH212-18. The sand was 0.9 m and 0.6 m thick in Boreholes BH201-18 and BH213-18, respectively. The sand continues to the termination depth in the remaining boreholes. The sand deposit was underlain by a silt and clay layer in Boreholes MW202-18 and BH204-18 at a depth of 1.5 m (Elevation 176.4 m) and 0.6 m (Elevation 178.8 m), and then continues again at a depth of 3.8 m (Elevation 174.1 m) and 0.9 m (Elevation 178.5 m) to the termination depth of each borehole. The sand typically ranges in composition from grey gravelly sand with some silt to brown silty sand with trace clay. The results of three grain/particle size distribution analyses conducted on the sand are provided in Appendix C and summarized in the following table;

TABLE 3 - RESULTS OF SAND PARTICLE/GRAIN SIZE DISTRIBUTION ANALYSES

Borehole Number	Sample Depth (m)	Gravel (%)	Sand (%)	Silt (%)	Clay (%)
BH217-18	1.52-2.13	0	74	25	1
BH220-18	3.05-3.66	8	62	24	6
BH216-18	4.57-5.18	0	98		2

SPT N-values measured in the sand typical increase with depth and range from 0 to 23 blows per 300 mm penetration of the split spoon sampler indicating very loose to compact conditions.

In situ moisture contents in the sand range from 6 to 30% indicating moist to saturated conditions.

5.0 GROUNDWATER CONDITIONS

Groundwater observations and measurements were carried out in the open boreholes at the time of drilling and are summarized on the borehole logs. Upon completion of drilling activities, free groundwater was encountered in all of the geotechnical boreholes and the depths and elevations are summarized in the following table;

TABLE 4 - GROUNDWATER DEPTHS AND ELEVATIONS UPON COMPLETION OF DRILLING

Borehole Number	Borehole Elevation (m)	Groundwater Depth (m)	Groundwater Elevation (m)
MW202-18	177.87	0.31	177.56
BH216-18	182.24	2.90	179.34
BH217-18	178.11	1.22	176.89
BH218-18	178.11	0.91	177.20
BH219-18	179.97	1.52	178.45
BH220-18	178.82	1.22	177.60

It should be noted that the groundwater levels can vary and are subject to seasonal fluctuations and local variations. Additional groundwater levels will be measured in the installed wells prior to finalization of the report.

6.0 DISCUSSION AND RECOMMENDATIONS

6.1 General

The project involves the design of a new residential development which will include 60 units total with 28 single detached residential buildings, 6 semi-detached residential buildings and 26 townhomes. The site is currently the Bay Moorings Marina located along Fox Street in Penetanguishene, Ontario. Three new roadways are proposed within the development.

The subsurface stratigraphy at the site comprises asphaltic concrete and/or fill overlying native sand, silt, and clay deposits. Free groundwater was encountered at Elevation 176.89 to 179.34 m upon completion of drilling activities.

Based on the results of this geotechnical investigation, the site is suitable for the proposed development; however the fill thickness, the low strength of the native soils and the high groundwater table will affect design and construction. The following subsections of this report contain geotechnical recommendations pertaining to development of the property including site grading, site servicing, foundations, floor slabs, pavement design, subdrainage requirements, and stormwater infiltration.

6.2 Site Preparation

The first construction activity that will be required for the proposed development will be grading. Due to the volume of fill at the site (average thickness = 1.9 m) and loose native soil deposits, it is understood leaving the existing fill in place is the preferred option. The residential units will need to be properly supported with deep foundations and roadways properly supported with geogrids and geotextiles.

The surficial organic topsoil would not be suitable to remain below the residential units and roadways and must be removed. The topsoil could be used in landscaping areas such as parks, pending consultation with environmental engineers.

These recommendations are subject to change if additional soil is to be removed as part of site remediation activities. The extent of the site remediation was unknown at the time of this report.

The native soils are not suitable for reuse as engineered fill due to high moisture contents. All engineered fill should be imported and placed in maximum 300 mm thick lifts, compacted to the following percentages;

TABLE 5 - ENGINEERED FILL REQUIREMENTS

Fill Use	Minimum Compaction Required
Structural fill to support structures	100% SPMDD
Subgrade fill beneath pavements or services	95% SPMDD
Bulk fill in landscape areas	90% SPMDD

Structural fill used for raising grades beneath the residential units should be comprised of granular material such as OPSS Granular 'A'. Subgrade fill material beneath the proposed pavement areas and services should meet the requirements of OPSS Select Subgrade Material. Any imported fill should be tested and verified by a geotechnical engineer prior to placement.

Structural fill pads should extend a minimum 0.3 m beyond the edge of the footing envelope of any building and down to subgrade at an angle of 45 degrees to the horizontal. Full time testing by geotechnical personnel is recommended during fill placement and compaction to monitor material quality, lift thickness, and verify the compaction by insitu density testing.

In order to minimize the effects of weather and groundwater, fill operations onsite should be carried out in the dry summer months.

6.3 Site Servicing

6.3.1 Excavations and Dewatering

The development will be serviced to provide the individual lots with full municipal services. It is anticipated that the invert levels for watermain and sanitary sewers will be at conventional depths.

Temporary excavations to conventional depths for installation of underground pipes at this site must comply with the Ontario Occupational Health and Safety Act and Regulations for Construction Projects. The fill would be classified as Type 4 soils and temporary side slopes must be trimmed back at an inclination of 3 horizontal to 1 vertical or less above the base of the trench as per O.Reg 213/91. The native soils encountered in the boreholes would be classified as Type 3 soils (O. Reg. 213/91, s. 226 (4)). Temporary side slopes must be cut at an inclination of 1.0 horizontal to 1.0 vertical or less from the base of the excavation for open cut pipe installation, exclusive of groundwater effects.

Trench side slopes must be continuously inspected, especially after periods of heavy rainfall or snow melt to identify areas of instability. Surface water should be directed away from entering the trench.

Moderate to high groundwater inflow should be expected where the excavations extend into the groundwater table encountered within the fill and native sand deposits. It is envisioned that groundwater inflow from the excavations extending up to 0.3 m below the groundwater regime can be controlled using a gravity dewatering system with properly constructed sumps and perimeter interceptor ditches and pumps. Well points or an equivalent system may be required for any excavation work extending more than 0.3 m below the groundwater regime.

It should be noted that a Permit to Take Water (PTTW), issued by the Ministry of Environment and Climate Change (MOECC), will be required if the dewatering system/sumps result in water taking of more than 50,000 L/day. The design of the dewatering system should be left to the contractor's discretion to control groundwater at least 0.5 m below the invert level in order to provide stable excavation base.

It is recommended that test pits be excavated during the tendering stage of the project to familiarize potential contractors of the soil and groundwater conditions at the site.

6.3.2 Pipe Bedding

It is anticipated invert elevation of the pipes will be at conventional 2 to 3 m depths below ground surface. The existing loose fill and organic soils contacted at the site are not suitable to support pipes without undergoing possible detrimental post-construction settlement. The fill and organic soil should be subexcavated from below the pipes and replaced with well-compacted granular soil, or the pipes should be constructed in structurally supported pipe conduits.

For non-critical flexible piping, the existing fill and organic soils may remain in place below the pipe invert provided that it is understood that some long-term settlement may occur.

Pipe bedding for water and sewer services should be conventional Class 'B' pipe bedding comprising a minimum 150 mm thick layer of OPSS Granular 'A' aggregate below the pipe invert. Granular 'A' type aggregate should be provided around the pipe to at least 300 mm above the pipe and the bedding aggregate should be compacted to a minimum 95% standard Proctor maximum dry density (SPMDD).

A well-graded clear stone such as Coarse Aggregate for HL4 Asphaltic Concrete (OPSS 1003) could be used in the sewer trenches as bedding below the spring line of the pipe to facilitate sump pump dewatering, if necessary. The clear stone should be compacted with a plate tamper

6.3.3 Groundwater Cutoffs

The proposed alignment of the sewers could create a hydraulic connection between groundwater regimes that are not currently connected. To prevent the movement of water along the pipe bedding, it is recommended that concrete or clay cutoff collars be installed. The cutoffs should be 1 m long and in place of regular bedding material.

6.3.4 Trench Backfilling

The trenches above the specified pipe bedding should be backfilled with engineered fill placed in 300 mm thick lifts and compacted to at least 95% SPMDD. Wet or saturated native mineral soils are not considered suitable for reuse as trench backfill. Any additional material required at the site should comprise imported granular soils such as OPSS Select Subgrade Material.

To minimize potential problems, backfilling operations should follow closely after excavation so that only a minimal length of trench is exposed. Care should be taken to protect side slopes of excavations by diverting surface run-off away from the excavations. If construction extends into the winter, then additional steps should be taken to minimize frost and ensure that frozen material is not used as backfill.

6.3.5 Manholes

The geotechnical bearing resistance at manhole locations should be analyzed for potential settlement prior to final design. Precast concrete manholes shall be backfilled with compacted Type 1 Granular 'B' material on all sides for ease of compaction and to minimize post-construction settlement. The backfill should be placed in maximum 500 mm thick lifts and brought up evenly on all sides in order to provide uniform lateral support and earth pressure. All precast manhole bases shall be set on a pad of drainage stone or Granular 'A' with a minimum thickness of 150 mm.

It is recommended that MTE review the final sewer invert and manhole elevations during design to confirm that the recommendations provided are sufficient for the proposed works.

6.4 Pavements

It is understood pavements will be constructed for the new roadways and parking areas at the site. MTE recommends that the roadways be supported with geogrids and geotextiles due to the existing fill.

A 270R Non-Woven Geotextile provided by Terrafix Geosynthetics Inc. in conjunction with a TX140 Geogrid supplied by Tensar International Corporation, or approved equivalent, is recommended to be placed on the subgrade to provide adequate material separation and strength for the pavement design. Final pavement design should be verified once design details are known. Tensar International Corporation product design information is provided in **Appendix D**.

The pavement component thicknesses in the following table are recommended based on the proposed pavement usage, the frost-susceptibility and strength of the subgrade soils, and the Tensar International Corporation SPECTRAPAVE4-PRO software;

TABLE 6 - PAVEMENT DESIGN

Pavement Component	Local Residential Street And Parking Areas
Asphalt Hot Mix	90 mm
OPSS 1010 Granular 'A' Base	150 mm
OPSS 1010 Granular 'B' Subbase	300 mm

The geogrids and geotextiles must be designed and installed by licensed service providers. The installation process must be inspected by a geotechnical engineer.

Samples of aggregates should be checked for conformance to OPSS 1010 prior to utilization on site and during construction. The Granular 'B' subbase and Granular 'A' base courses must be compacted to 100% SPMDD, as verified by insitu density testing.

The asphaltic concrete paving materials should conform to the requirements of OPSS 1150. The asphalt should be placed and compacted in accordance with OPSS 310. The Performance Graded Asphalt Cement designation for the asphaltic concrete is 58-28.

The asphaltic concrete should comprise 40 mm of HL4 surface over 50 mm of HL8 binder for local residential streets.

The pavement design is based on the assumption that construction will be carried out during the drier time of the year and that the subgrade soil is stable and geogrid and geotextile installation inspection by a geotechnical engineer. If the subgrade is wet and unstable, additional granular subbase will be required.

All materials and construction services required for the work should be in accordance with the relevant sections of the Ontario Provincial Standard Specifications.

It is recommended to install subdrains beneath the low areas of pavement and connected to catchbasins. The purpose of the subdrains is to remove excess subsurface water in order to improve overall pavement serviceability and increase the pavement life. Consideration should be given to providing continuous subdrains along the perimeter edges of the new street to promote drainage of the granular materials.

The work of subdrain installation shall be in accordance with OPSS 405 and OPSD 216.021. The subdrain shall be 100 or 150 mm diameter perforated pipe conforming to OPSS 1801 or 1840, and wrapped with geotextile conforming to OPSS 1860.

6.5 Curbs, Gutter and Sidewalks

The concrete for curbs, gutters and sidewalks should be proportioned, mixed, placed and cured in accordance with the requirements of OPSS 353, and OPSS 1350 and shall meet the following specific requirements (OPSS 353.05.01):

- Minimum compressive strength = 30 MPa at 28 days
- Coarse aggregate = 19.0 mm nominal max. size
- Maximum slump = 60 mm for curb and gutter, 70 mm for sidewalk
- Air entrainment = $7.0 \pm 1.5\%$

During cold weather any freshly placed concrete must be covered with insulating blankets to protect against freezing as per OPSS 904. Three cylinders from each days pour should be taken for compressive strength testing. Air entrainment, temperature and slump tests should be conducted on the same batch of concrete from the test cylinders made.

6.6 Residential Foundation Design

Considering the presence of fill and soft silt and clay stratum at deeper depths and associated significant consolidation settlements due to structural loads, it is recommended that the foundations for the proposed residential units be placed on helical piles.

A helical pier foundation system comprises medium diameter steel helices on the end of small diameter solid steel shafts. The steel helices are screwed into the ground to the level of competent bearing soil and attached to grade beams to support the residential units. A pull-down grout system should be used in order to encase the shaft and to provide additional support, lifting resistance and longevity of the foundation system

The piles would be drilled through the existing fill and loose native soils and into the compact native soils encountered approximately at a depth of 9.1 m. Chance SS5 Helical Pile with a compression capacity of 200 kN at Serviceability Limit States (SLS) and 270 kN at Ultimate Limit States (ULS) supplied by EBS Geotechnical Inc. or approved equivalent would be adequate to support the residential units. Design dimensions and a product information are provided in **Appendix E**.

The individual pier loading should be confirmed by the contractor supplying and installing the helical piers and by load tests (larger diameter helices could support higher loads). The center-to-center spacing of piles should be at least three times the helix diameter. The pile stability, pile head and pile cap details should be determined and checked by an experienced Structural Engineer and reviewed by the Geotechnical Consultant.

The helical pier installation operations should be monitored on a full-time basis by qualified geotechnical personnel to check foundation elevation, and allowable pier loading through torque testing

The helical piles must be designed and installed by licensed service providers. The installation process must be inspected by a geotechnical engineer.

The grade beams between the helical piers must be provided with a minimum 1.2 m of earth cover after final grading in order to minimize the potential of damage due to frost action. If construction is undertaken during the winter, the subgrade soil and concrete should be protected from freezing.

All excavations at the site should be carried out in conformance with the Ontario Occupational Health and Safety Act and Regulations for Construction Projects. The fill would be classified as Type 4 soils and temporary side slopes must be trimmed back at an inclination of 3 horizontal to 1 vertical or less above the base of the trench as per O.Reg 213/91 s.234(2). The trench side slopes must be cut back at a shallower angle where waterbearing deposits are encountered.

6.7 Concrete Slab-on-Grade Floors

It is recommended the floor slabs be designed as structural slabs due to the low strength of the fill onsite. MTE does not recommend the construction of basements due to the low strength of native soils and high groundwater table at the site.

No significant methane gas headspace readings were recorded in the fill. Please refer to MTE's due diligence Phase 2 ESA conducted on October 16, 2017, File No. 43022-100, for the results of the methane gas headspace readings.

Any additional material required to raise grades below the floor slabs should be comprised of sand and gravel and be compacted to 100% SPMDD. A minimum 150 mm thick layer of Granular 'A' material uniformly compacted to 100% SPMDD should be provided directly beneath the slab for leveling and support purposes.

No special underfloor drains are required, provided the exterior grades are lower than the floor slab and positively sloped away from the building.

The water to cement ratio and slump of the concrete utilized in the floor slab should be strictly controlled to minimize shrinkage of the slab. Control joints should be sawed into the slabs at regular intervals within 12 hours of initial concrete placement in order to pre-locate shrinkage cracks.

Concrete testing should be performed onsite to determine the slump, temperature, and air entrainment; and concrete cylinders should be cast for compressive strength testing.

6.8 Stormwater Infiltration

It is understood that at-source infiltration of stormwater runoff from the development may be considered for this site. Soak-away pits generally require native soils with a minimum percolation rate of 15 mm/hr and a minimum separation between the bottom of the pit and the seasonally high water table of 1 m (MOE, 2003).

Due to the high groundwater table, at approximately Elevation 176.89 to 179.34 m, and the large amount of fill materials at the site, at-source infiltration of stormwater runoff is not geotechnically feasible for the development.

7.0 LIMITATIONS OF REPORT

Services performed by **MTE Consultants Inc.** (MTE) were conducted in a manner consistent with the level of care and skill ordinarily exercised by members of the Geotechnical Engineering & Consulting profession practicing under similar conditions in the same geographic area where the services are provided. No other warranty or representation expressed or implied as to the accuracy of the information, conclusions or recommendations is included or intended in this report.

This report was completed for the sole use of the Client. This report is not intended to be exhaustive in scope or to imply a risk-free site. As such, this report may not deal with all issues potentially applicable to the site and may omit aspects which are or may be of interest to the reader.

In addition, it should be recognized that a soil sample result represents one distinct portion of a site at the time it is collected, and that the findings of this report are based on conditions as they existed during the time period of the investigation. The material in the report reflects our best judgment using the information available at the time the report was written. The soil and groundwater conditions between and beyond the test holes may differ from those encountered in the test holes. Should subsurface conditions arise that are different from those in the test holes MTE should be notified to determine whether or not changes should be made as a result of these conditions.

It should be recognized that the passage of time may affect the views, conclusions and recommendations (if any) provided in this report because groundwater conditions of a property can change, along with regulatory requirements. All design details were not known at the time of submission of this report and it is recommended MTE should be retained to review the final design documents prior to construction to confirm they are consistent with our report recommendations. Should additional or new information become available, MTE recommends that it be brought to our attention in order that we may determine whether it affects the contents of this report.

Any use which another party makes of this report, or any reliance on, or decisions to be made based upon it, are the responsibility of such parties. MTE accepts no responsibility for liabilities incurred by or damages, if any, suffered by another party as a result of decisions made or actions taken, based upon this report. Others with interest in the site should undertake their own investigations and studies to determine how or if the condition affects them or their plans. The contractors bidding on this project or undertaking the construction should make their own interpretation of the factual information and draw their own conclusions as to how subsurface conditions may affect their work.

The benchmark and elevations provided in this report are primarily established to identify differences between the test hole locations and should not be used for other purposes such as, planning, development, grading, and excavation.

Respectfully submitted,

MTE CONSULTANTS INC.

Ben Heinbuch, EIT
Senior Geotechnical Technician

MXW:dld

Montana Wilson, M.Eng. P.Eng. PMP
Civil and Geotechnical Division Manager

DRAFT



FIGURES

Figure 1- Location Plan
Figure 2 - Site Plan

DRAFT

FIGURE 1

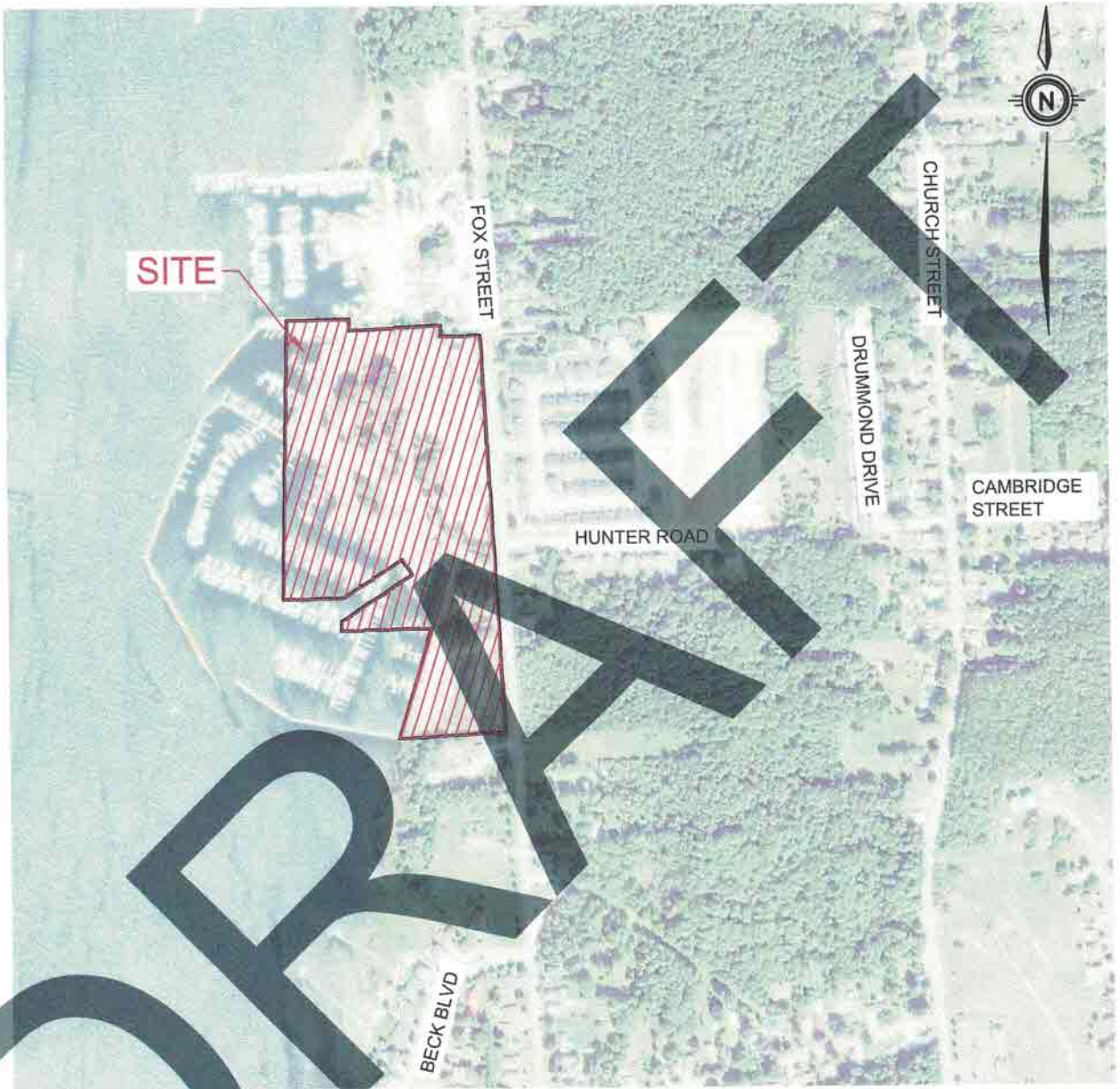

ARIEL IMAGE FROM GOOGLE EARTH

LOCATION PLAN



<u>Project Name</u> FOX STREET PENETANGUISHENE SUBDIVISION			
<u>Site</u> 160 - 200 FOX STREET, PENETANGUISHENE, ONTARIO		<u>Client</u> WILMINGTON CAPITAL MANAGEMENT INC.	
<u>Scale</u> (8.5x11) N.T.S	<u>MTE Project No.</u> 43022-100	<u>Date</u> MAY.01.2018	<u>Figure No.</u> 1

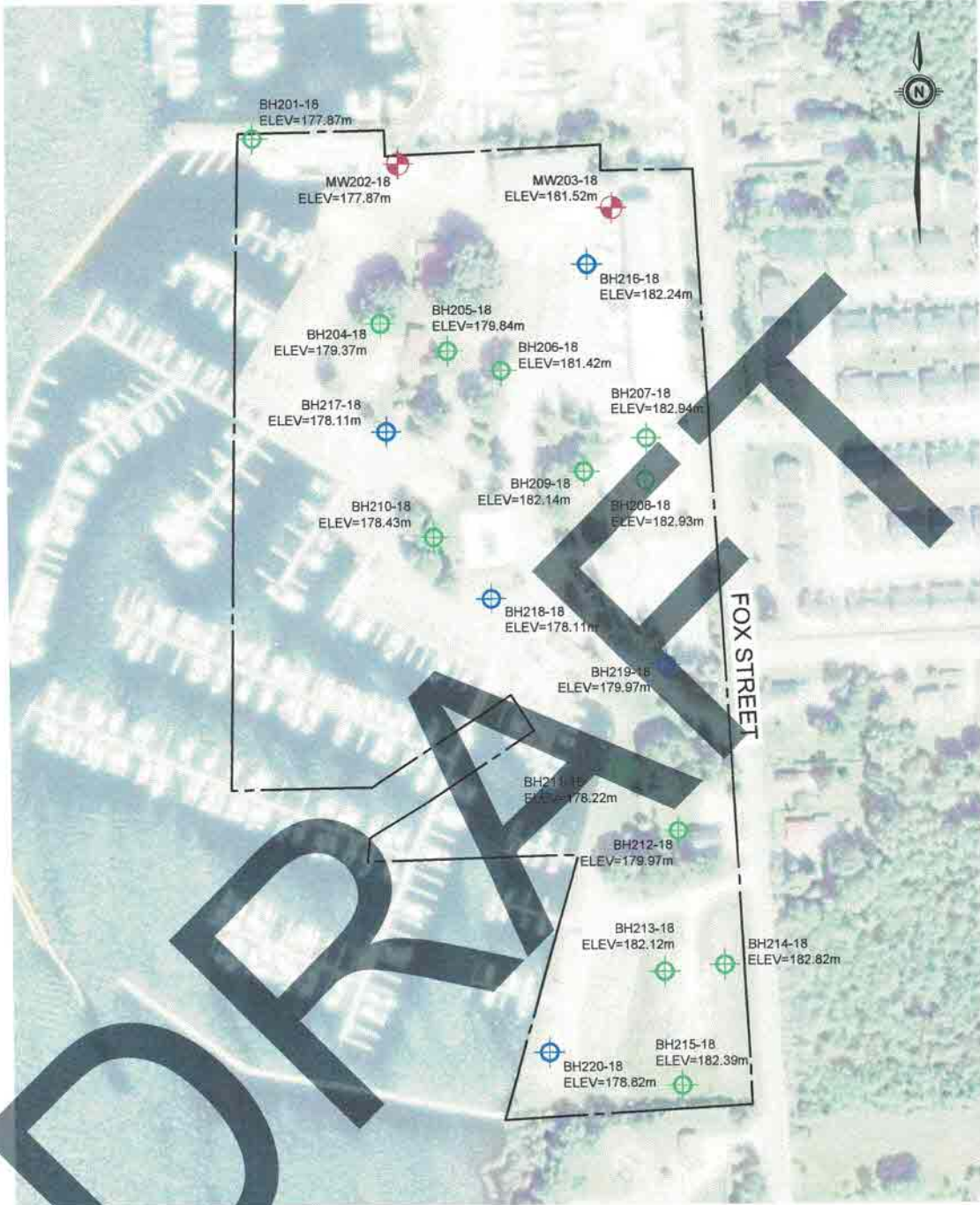

LEGEND

- BH201-18
 DIRECT PUSH METHOD BOREHOLE
- BH216-18
 HOLLOW STEM AUGERS BOREHOLE
- MW202-18
 MONITORING WELL

REFERENCES:

- ARIEL IMAGE FROM GOOGLE EARTH
 - THE GROUND SURFACE ELEVATIONS AT THE BOREHOLE LOCATIONS WERE SURVEYED BY MTE BY THE USE OF A TRIMBLE SURVEY DEVICE AND TIED INTO GEODETIC ELEVATIONS.

SITE PLAN



Project Name FOX STREET PENETANGUISHENE SUBDIVISION			
Site 190 - 200 FOX STREET, PENETANGUISHENE, ONTARIO		Client WILMINGTON CAPITAL MANAGEMENT INC.	
Scale: (1:1x17) 1:2000	MTE Project No. 43022-100	Date MAY.01.2018	Figure No. 2



BOREHOLE LOGS

Boreholes BH201-18
to BH220-18

DRAFT

ID Number: BH201-18

Project: Fox Street, Penetanguishene Development

Project No: 43022-100

Client: Wilmington Capital Management Inc.

Site Location: 160 - 200 Fox Street, Penetanguishene, ON

Drill Date: 3/26/2018

Drilling Contractor: Direct Environmental Drilling

Drill Rig: Geoprobe 7822DT

Drill Method: Direct Push

Protective Cover: N/A

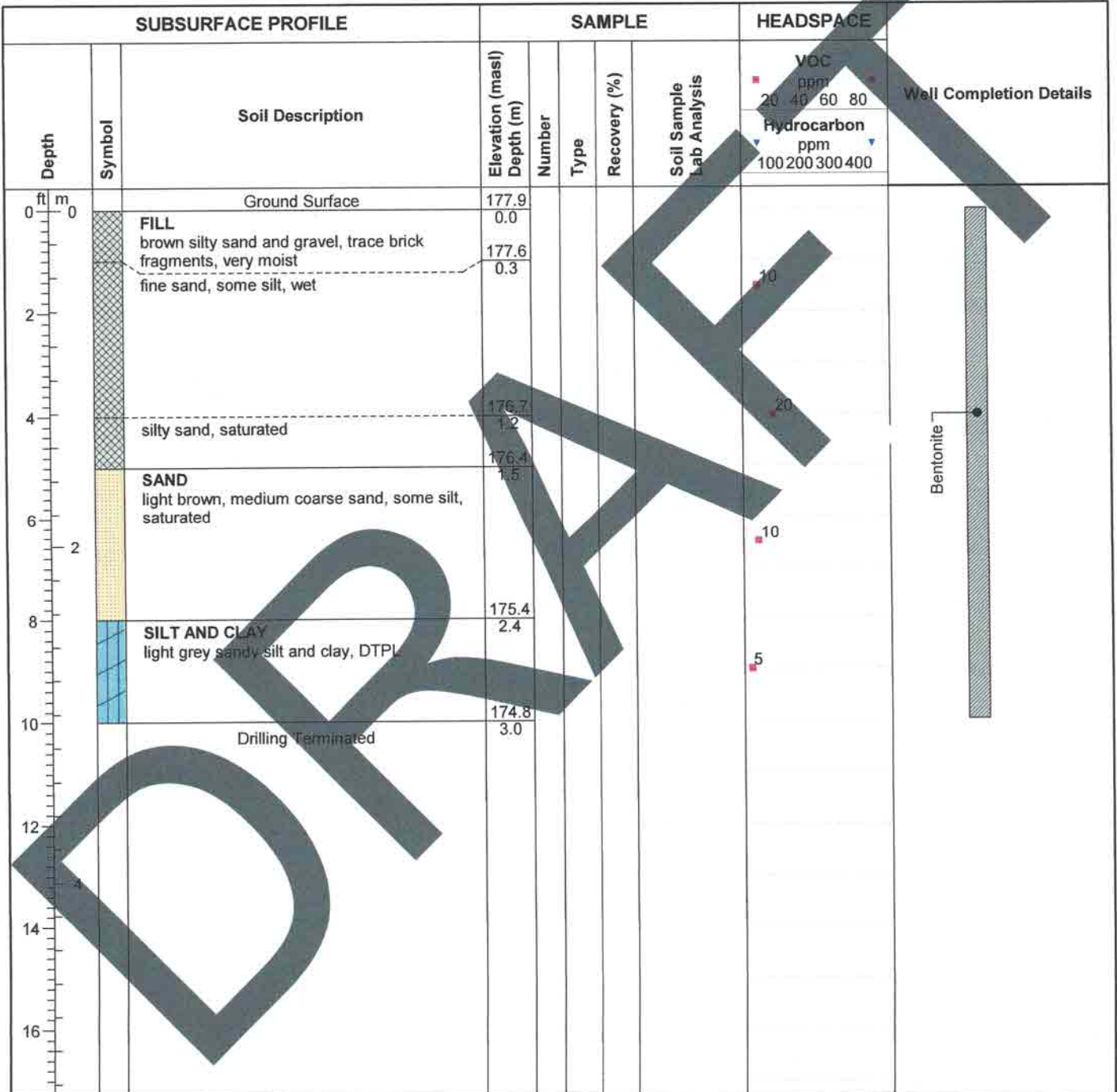

Field Technician: K. Maddock

Drafted by: S. Rederer

Reviewed by: R. Fedy



ID Number: MW202-18

Project: Fox Street, Penetanguishene Development

Project No: 43022-100

Client: Wilmington Capital Management Inc.

Site Location: 160 - 200 Fox Street, Penetanguishene, ON

Drill Date: 3/26/2018

Drilling Contractor: Direct Environmental Drilling

Drill Rig: Geoprobe 7822DT

Drill Method: Hollow Stem Augers

Protective Cover: N/A

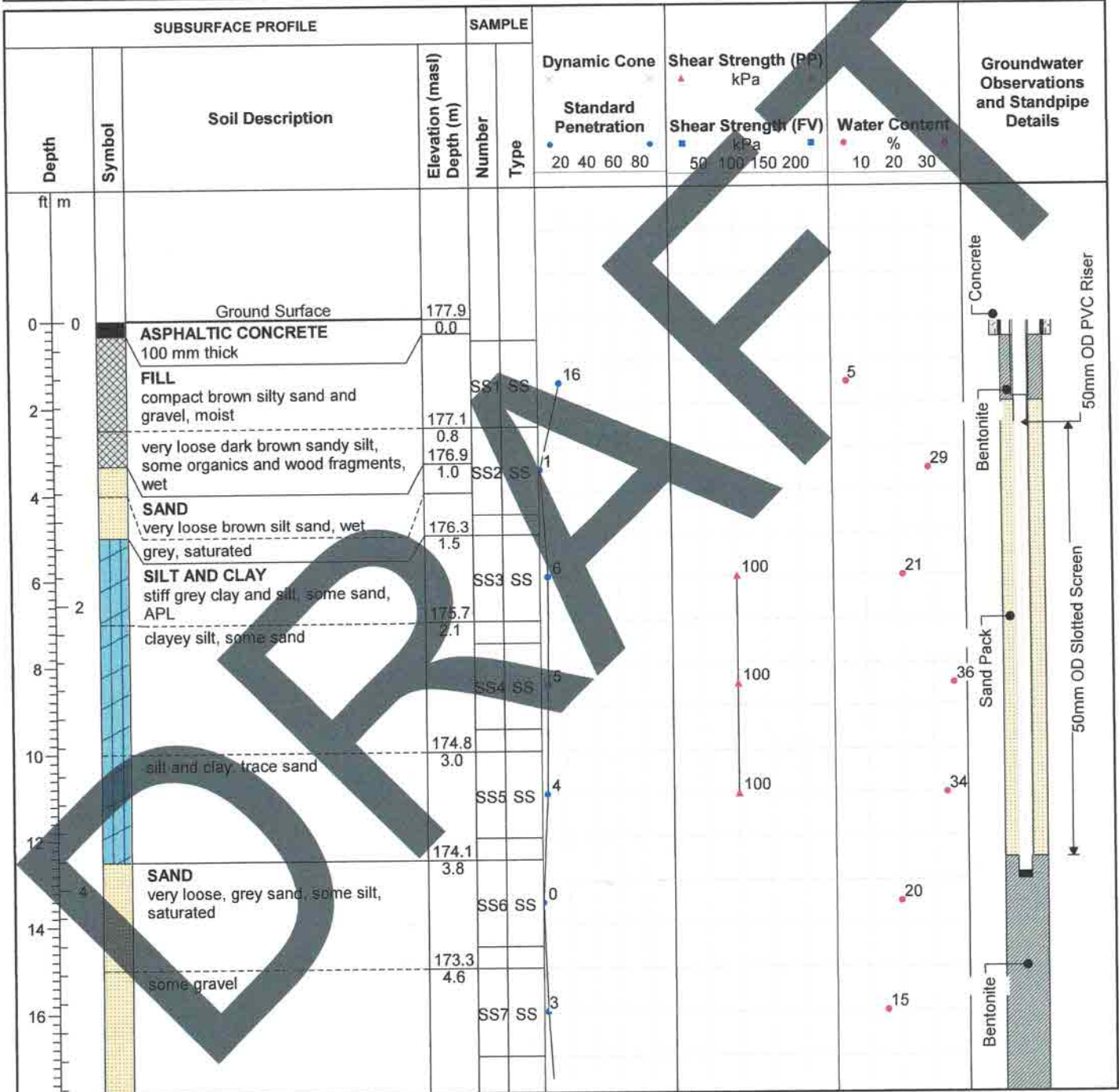

Field Technician: M. Dalglish

Drafted by: B. Heinbuch

Reviewed by: M. Wilson



ID Number: MW202-18

Project: Fox Street, Penetanguishene Development

Project No: 43022-100

Client: Wilmington Capital Management Inc.

Site Location: 160 - 200 Fox Street, Penetanguishene, ON

Drill Date: 3/26/2018

Drilling Contractor: Direct Environmental Drilling

Drill Rig: Geoprobe 7822DT

Drill Method: Hollow Stem Augers

Protective Cover: N/A

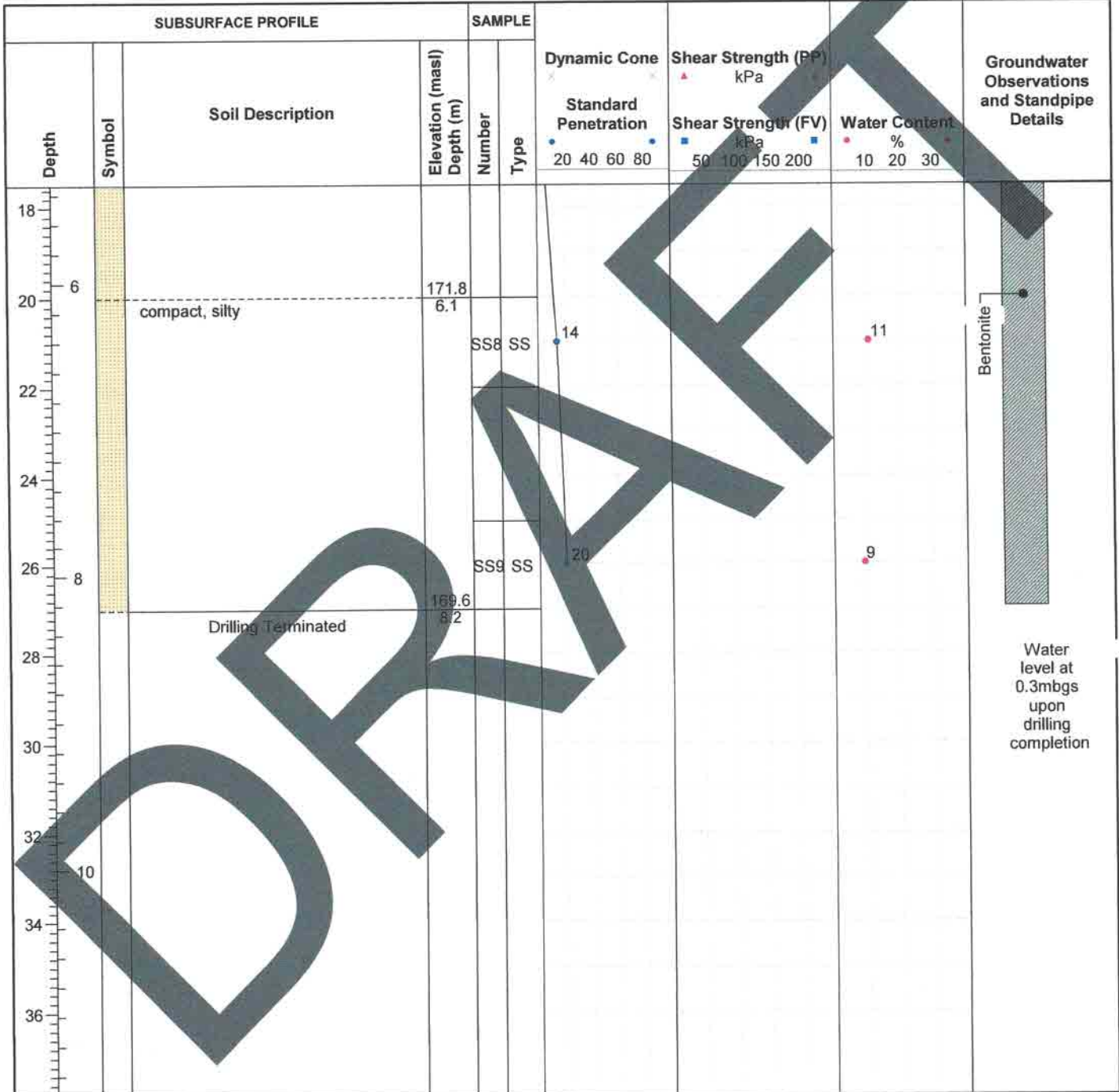

Field Technician: M. Dalglish

Drafted by: B. Heinbuch

Reviewed by: M. Wilson



ID Number: MW203-18

Project: Fox Street, Penetanguishene Development

Project No: 43022-100

Client: Wilmington Capital Management Inc.

Site Location: 160 - 200 Fox Street, Penetanguishene, ON

Drill Date: 4/9/2018

Drilling Contractor: Direct Environmental Drilling

Drill Rig: Bosch Pionjar

Drill Method: Direct Push

Protective Cover: Monument

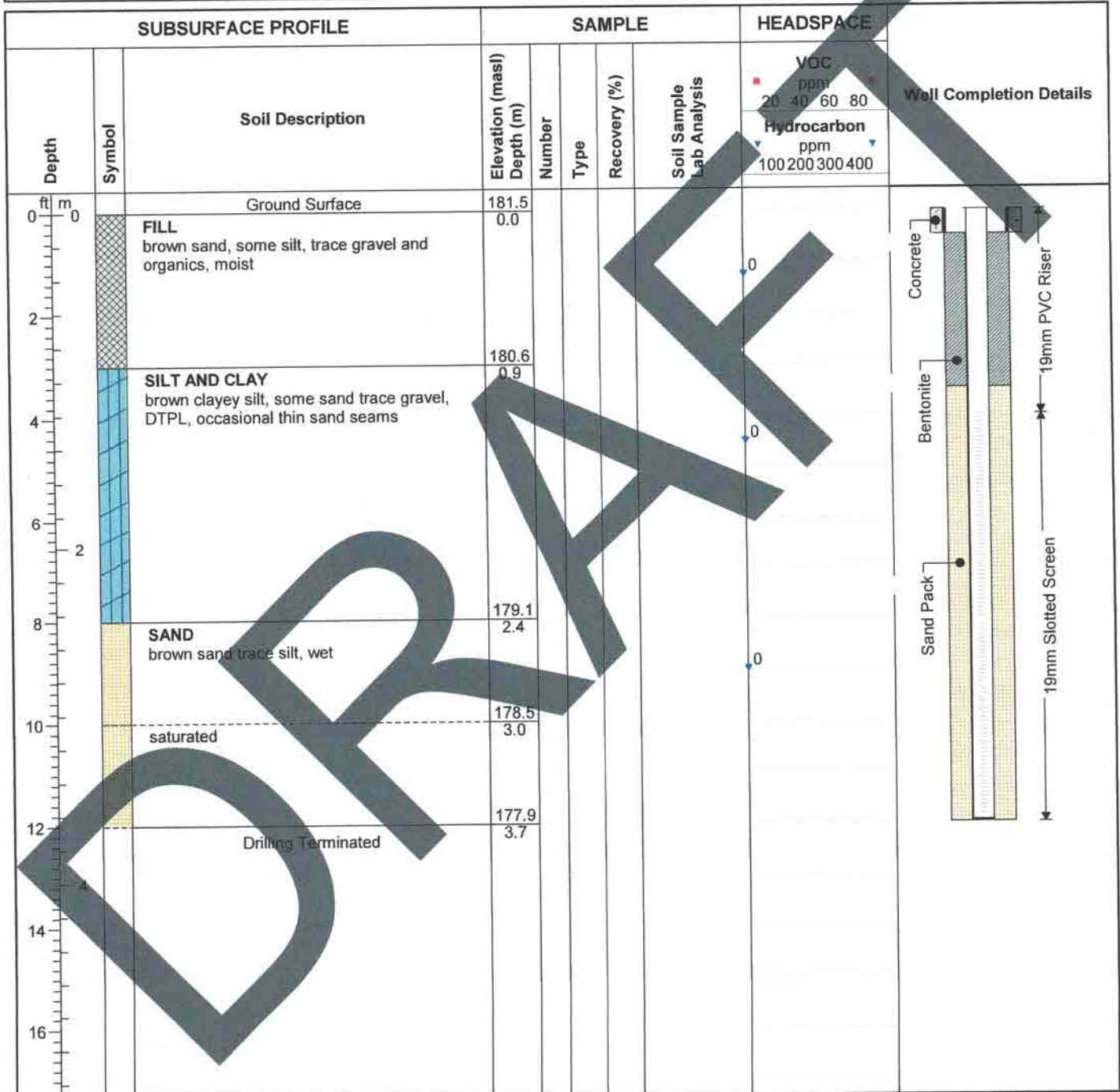

Field Technician: K. Maddock

Drafted by: S. Rederer

Reviewed by: R. Fedy



ID Number: BH204-18

Project: Fox Street, Penetanguishene Development

Project No: 43022-100

Client: Wilmington Capital Management Inc.

Site Location: 160 - 200 Fox Street, Penetanguishene, ON

Drill Date: 4/9/2018

Drilling Contractor: Direct Environmental Drilling

Drill Rig: Geoprobe 7822DT

Drill Method: Direct Push

Protective Cover: N/A

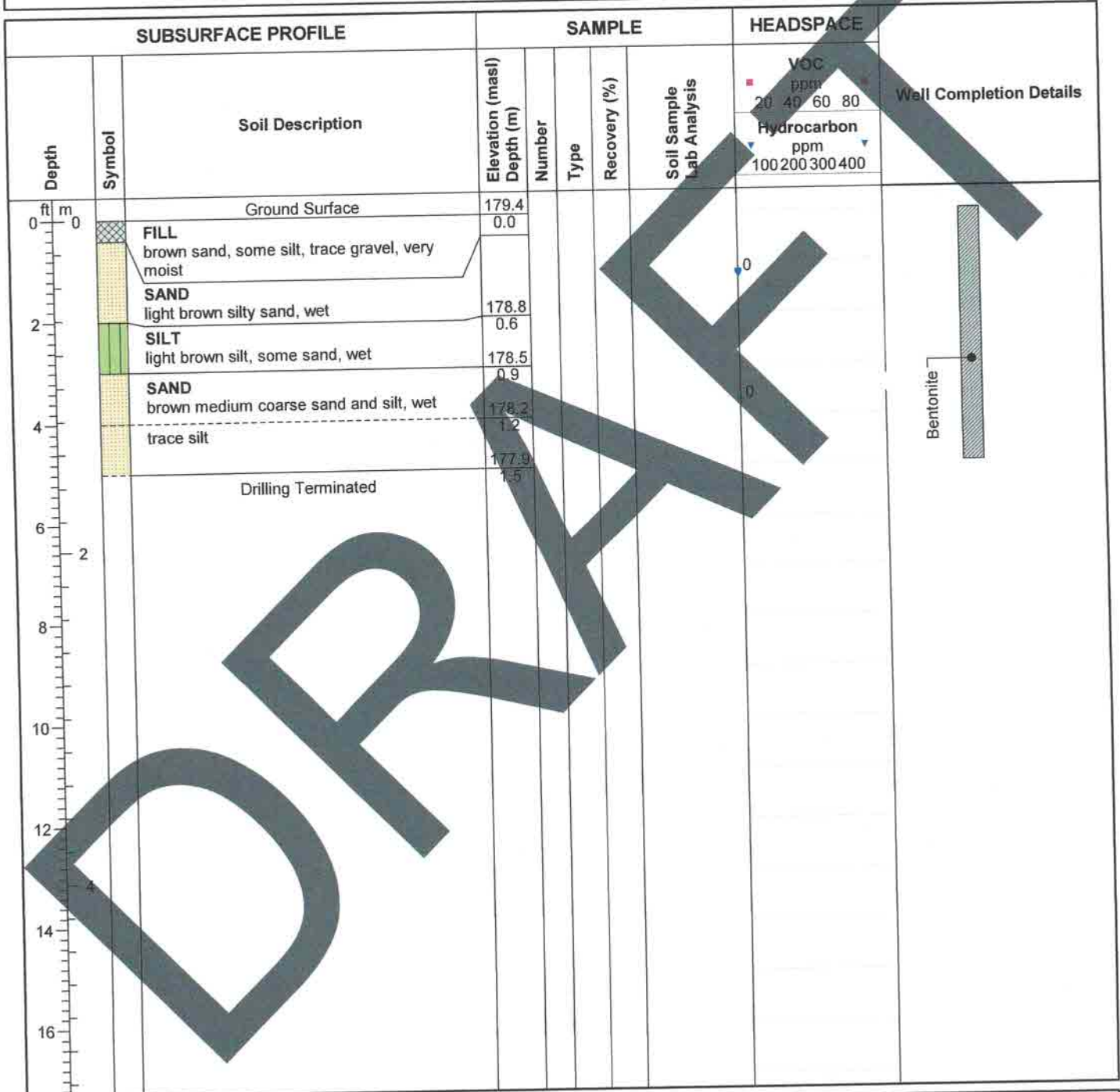

Field Technician: K. Maddock

Drafted by: S. Rederer

Reviewed by: R. Fedy



ID Number: BH205-18

Project: Fox Street, Penetanguishene Development

Project No: 43022-100

Client: Wilmington Capital Management Inc.

Site Location: 160 - 200 Fox Street, Penetanguishene, ON

Drill Date: 4/9/2018

Drilling Contractor: Direct Environmental Drilling

Drill Rig: Geoprobe 7822DT

Drill Method: Direct Push

Protective Cover: N/A

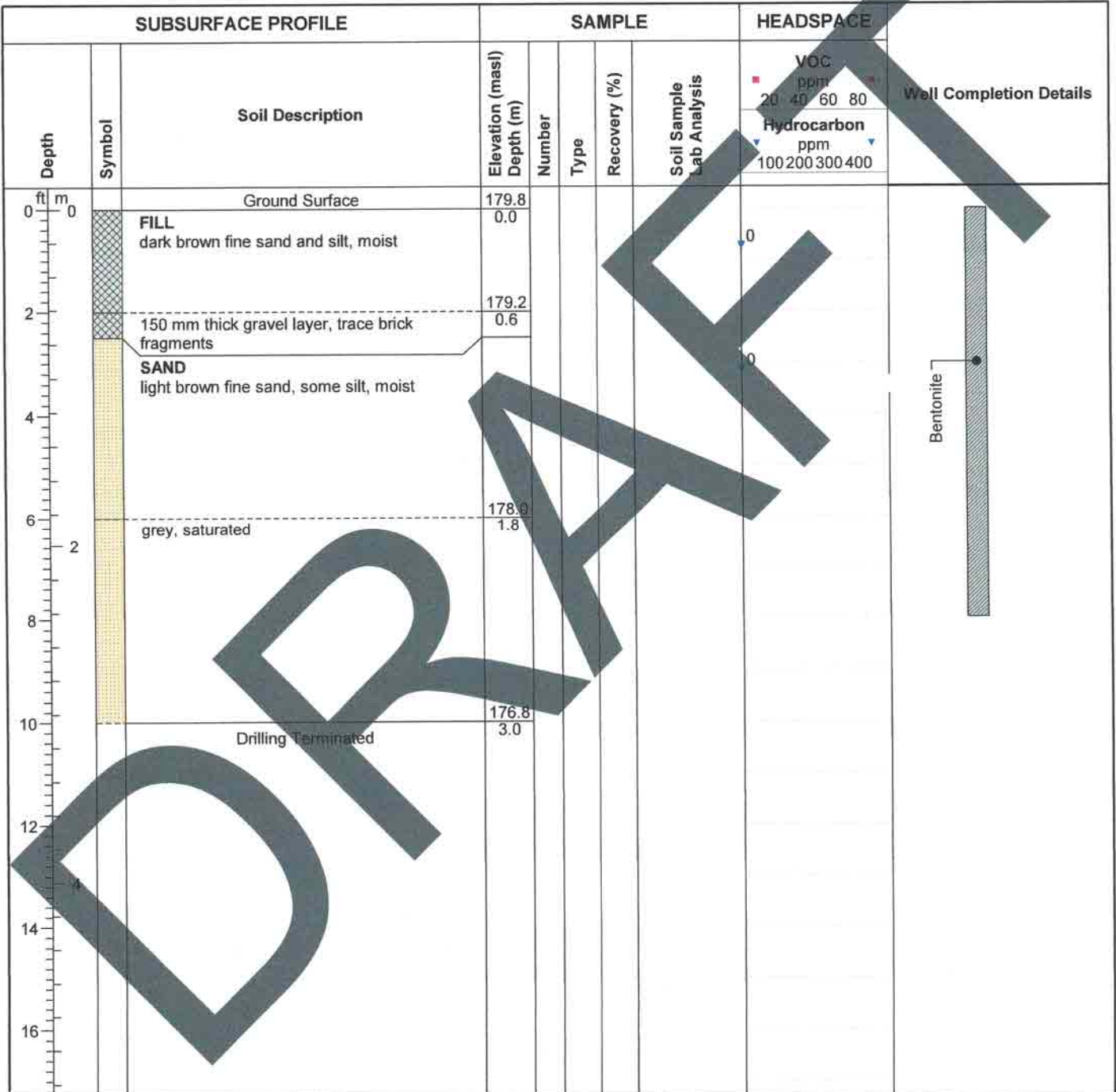

Field Technician: K. Maddock

Drafted by: S. Rederer

Reviewed by: R. Fedy



ID Number: BH206-18

Project: Fox Street, Penetanguishene Development

Project No: 43022-100

Client: Wilmington Capital Management Inc.

Site Location: 160 - 200 Fox Street, Penetanguishene, ON

Drill Date: 4/10/2018

Drilling Contractor: Direct Environmental Drilling

Drill Rig: Geoprobe 7822DT

Drill Method: Direct Push

Protective Cover: N/A

SUBSURFACE PROFILE		SAMPLE				HEADSPACE	Well Completion Details		
Depth	Symbol	Soil Description	Elevation (masl) Depth (m)	Number	Type	Recovery (%)		Soil Sample Lab Analysis	VOC ppm 20 40 60 80
0		Ground Surface	181.4						
0		FILL brown silty sand, trace gravel and clay	0.0						
		sand, some silt, some gravel, trace organics	181.1						
2									
4		SAND brown, trace silt, moist	180.2						
			179.9						
6		Drilling Terminated	179.5						
8									
10									
12									
14									
16									

Field Technician: K. Maddock

Drafted by: S. Rederer

Reviewed by: R. Fedy



ID Number: BH207-18

Project: Fox Street, Penetanguishene Development

Project No: 43022-100

Client: Wilmington Capital Management Inc.

Site Location: 160 - 200 Fox Street, Penetanguishene

Drill Date: 4/10/2018

Drilling Contractor: Direct Environmental Drilling

Drill Rig: Geoprobe 7822DT

Drill Method: Direct Push

Protective Cover: N/A

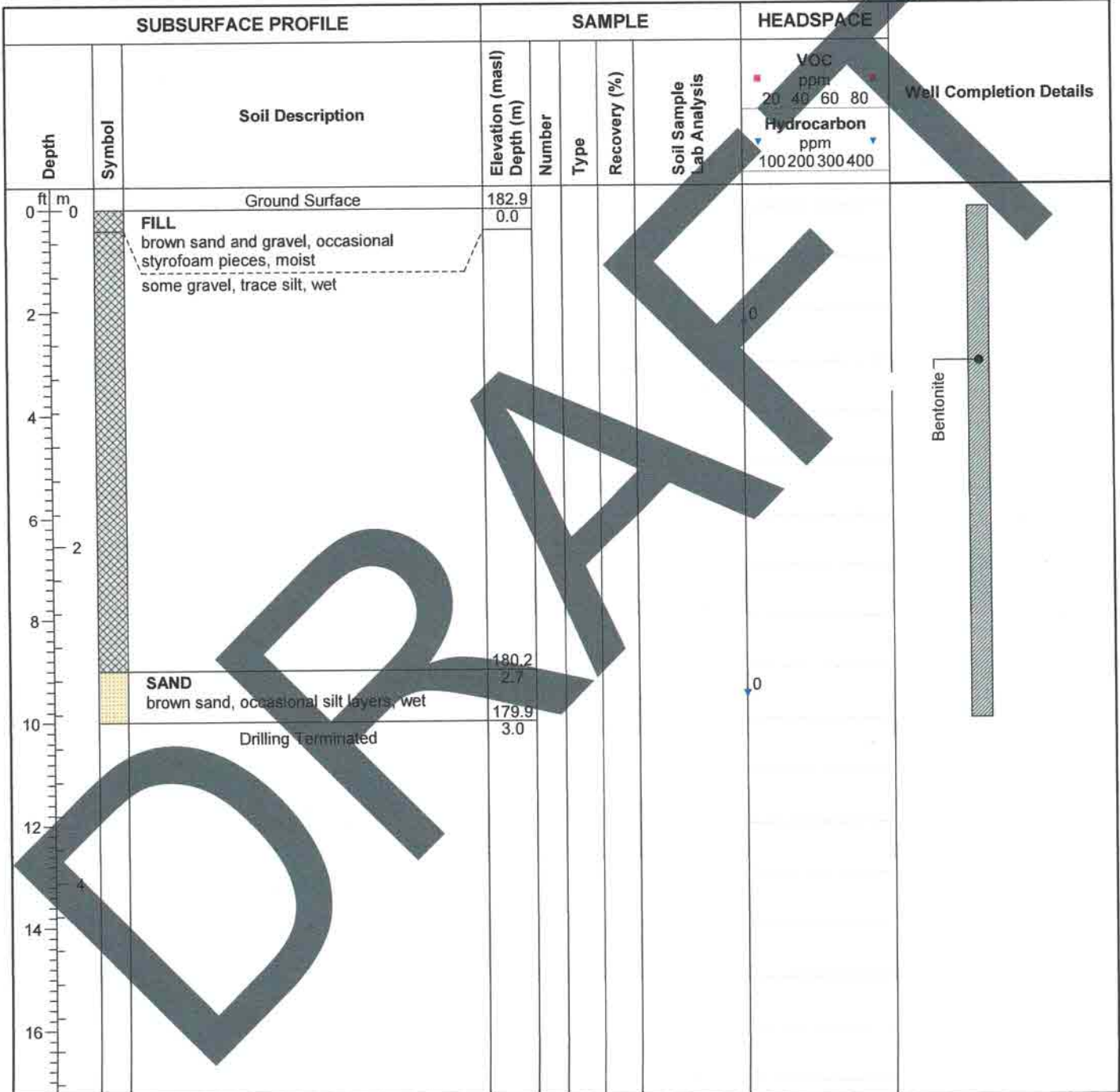

Field Technician: K. Maddock

Drafted by: S. Rederer

Reviewed by: R. Fedy



ID Number: BH208-18

Project: Fox Street, Penetanguishene Development

Project No: 43022-100

Client: Wilmington Capital Management Inc.

Site Location: 160 - 200 Fox Street, Penetanguishene, ON

Drill Date: 4/10/2018

Drilling Contractor: Direct Environmental Drilling

Drill Rig: Geoprobe 7822DT

Drill Method: Direct Push

Protective Cover: N/A

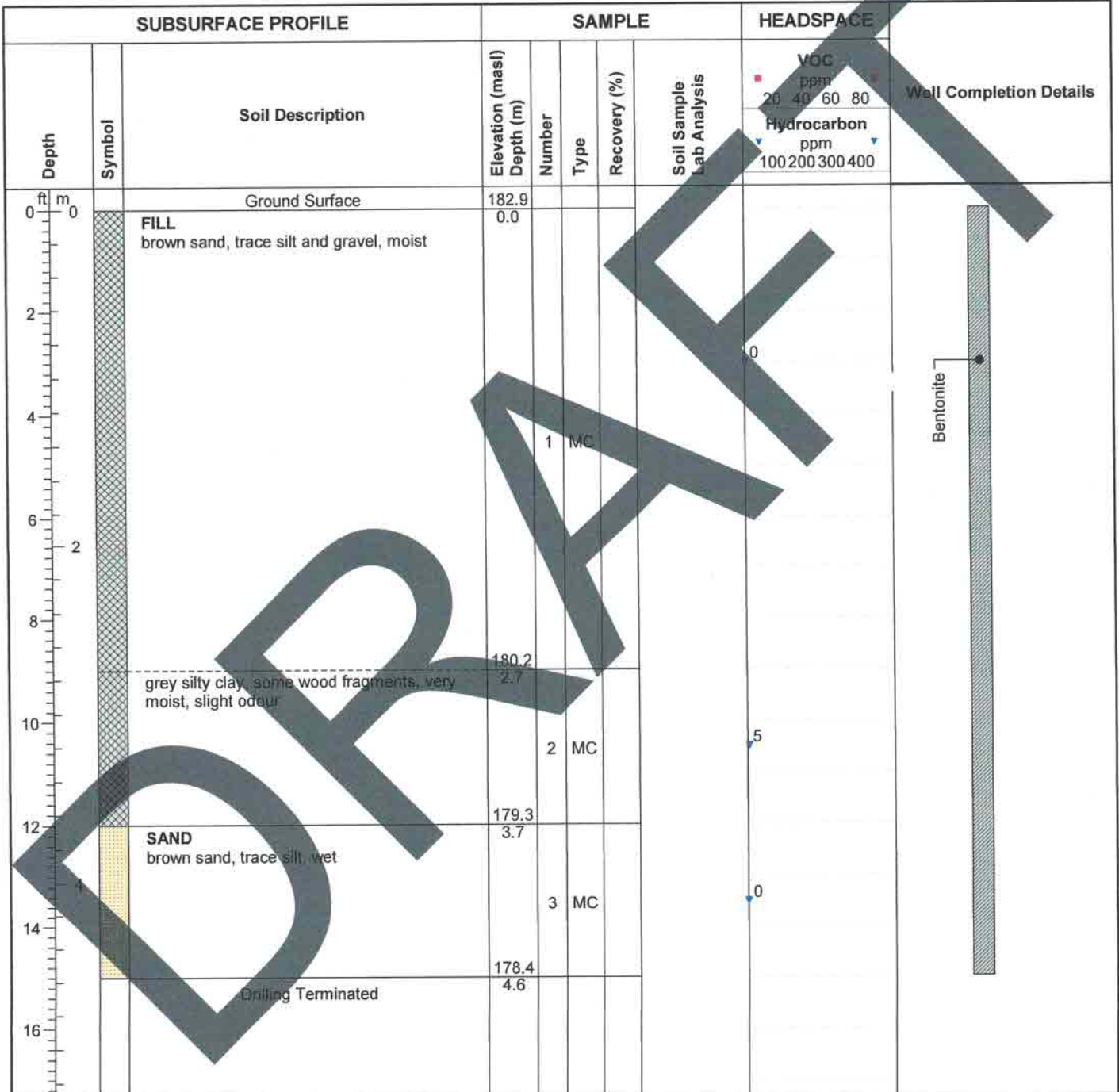

Field Technician: K. Maddock

Drafted by: S. Rederer

Reviewed by: R. Fedy



ID Number: BH209-18

Project: Fox Street, Penetanguishene Development

Project No: 43022-100

Client: Wilmington Capital Management Inc.

Site Location: 160 - 200 Fox Street, Penetanguishene, ON

Drill Date: 4/10/2018

Drilling Contractor: Direct Environmental Drilling

Drill Rig: Geoprobe 7822DT

Drill Method: Direct Push

Protective Cover: N/A

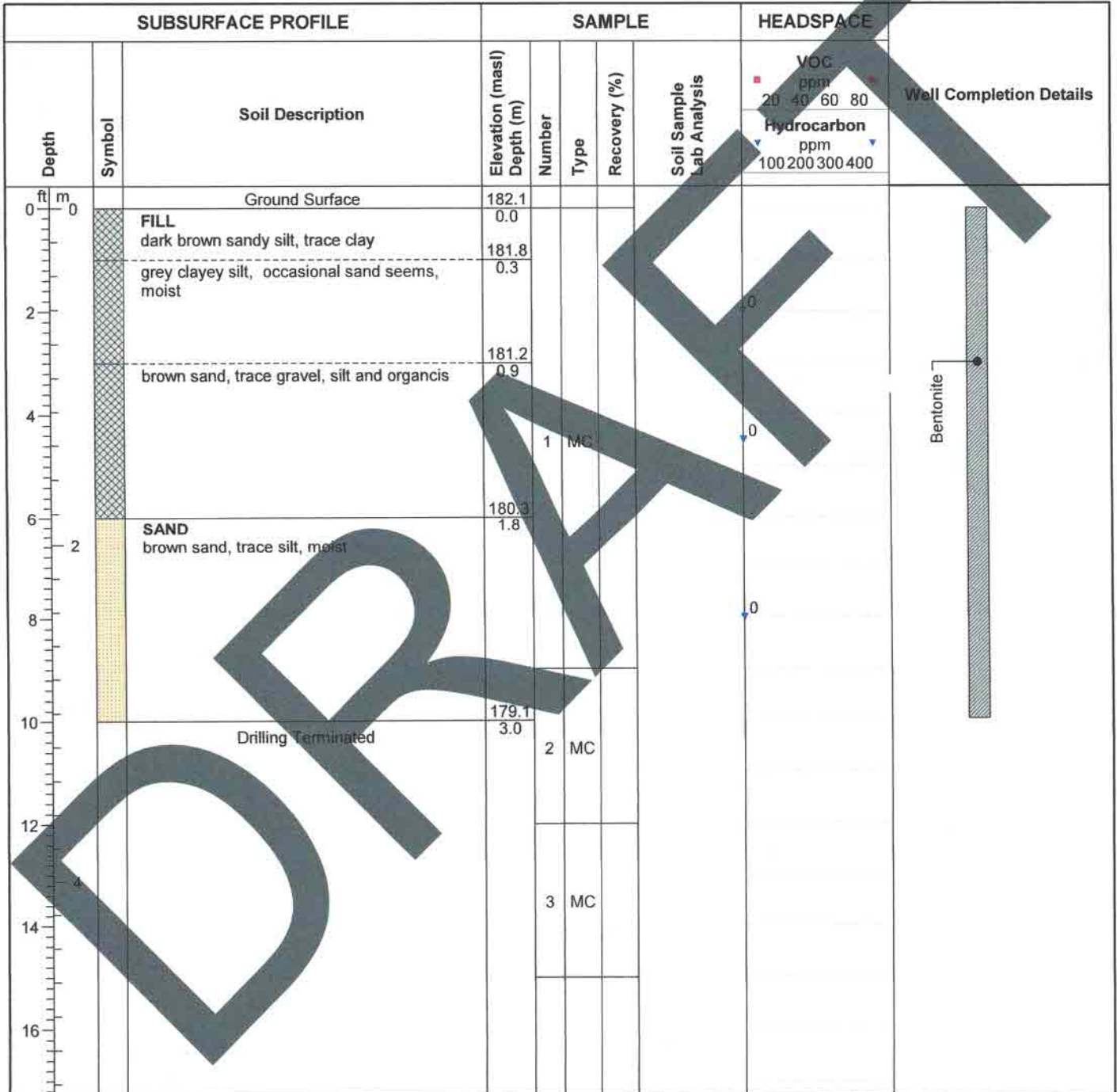

Field Technician: K. Maddock

Drafted by: S. Rederer

Reviewed by: R. Fedy



ID Number: BH210-18

Project: Fox Street, Penetanguishene Development

Project No: 43022-100

Client: Wilmington Capital Management Inc.

Site Location: 160 - 200 Fox Street, Penetanguishene, ON

Drill Date: 4/9/2018

Drilling Contractor: Direct Environmental Drilling

Drill Rig: Geoprobe 7822DT

Drill Method: Direct Push

Protective Cover: N/A

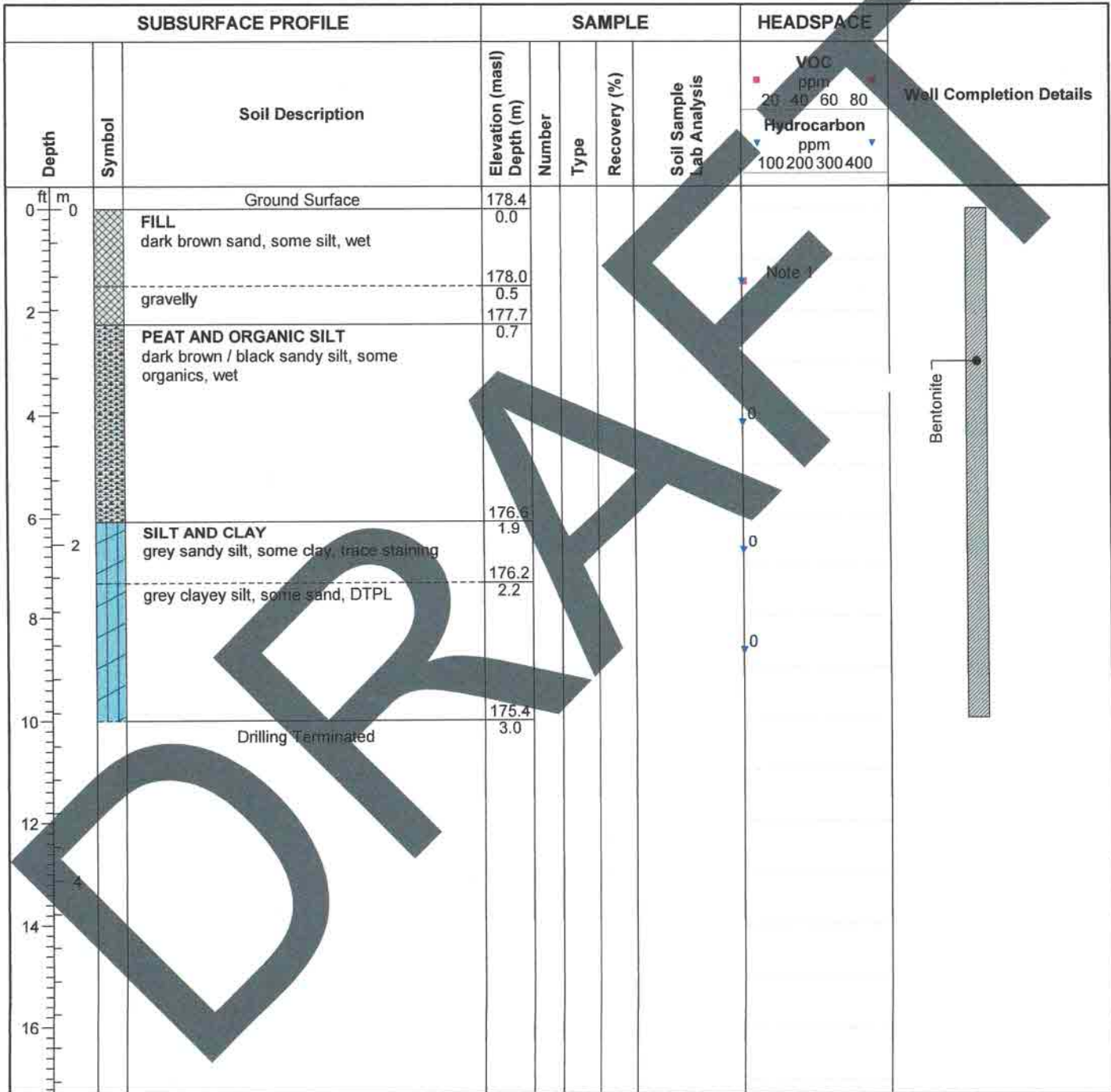

Field Technician: K. Maddock

Drafted by: S. Rederer

Reviewed by: R. Fedy



Notes:
1) PHC: 0, VOC: 1

ID Number: BH211-18

Project: Fox Street, Penetanguishene Development

Project No: 43022-100

Client: Wilmington Capital Management Inc.

Site Location: 160 - 200 Fox Street, Penetanguishene, ON

Drill Date: 4/9/2018

Drilling Contractor: Direct Environmental Drilling

Drill Rig: Geoprobe 7822DT

Drill Method: Direct Push

Protective Cover: N/A

SUBSURFACE PROFILE			SAMPLE				HEADSPACE		Well Completion Details
Depth	Symbol	Soil Description	Elevation (masl) Depth (m)	Number	Type	Recovery (%)	Soil Sample Lab Analysis	VOC ppm 20 40 60 80 Hydrocarbon ppm 100 200 300 400	
0		Ground Surface	178.2						
0		FILL	0.0						
		brown silt (topsoil), moist	178.0						
		brown silty sand and gravel	0.2						
2		dark brown/black sandy silt, some organics and topsoil, wet	177.5						
		SAND	0.7						
		brown silty sand, saturated							
4									
6		Drilling Terminated	176.7						
8			1.5						
10									
12									
14									
16									

Field Technician: K. Maddock

Drafted by: S. Rederer

Reviewed by: R. Fedy



ID Number: BH212-18

Project: Fox Street, Penetanguishene Development

Project No: 43022-100

Client: Wilmington Capital Management Inc.

Site Location: 160 - 200 Fox Street, Penetanguishene, ON

Drill Date: 4/9/2018

Drilling Contractor: Direct Environmental Drilling

Drill Rig: Geoprobe 7822DT

Drill Method: Direct Push

Protective Cover: N/A

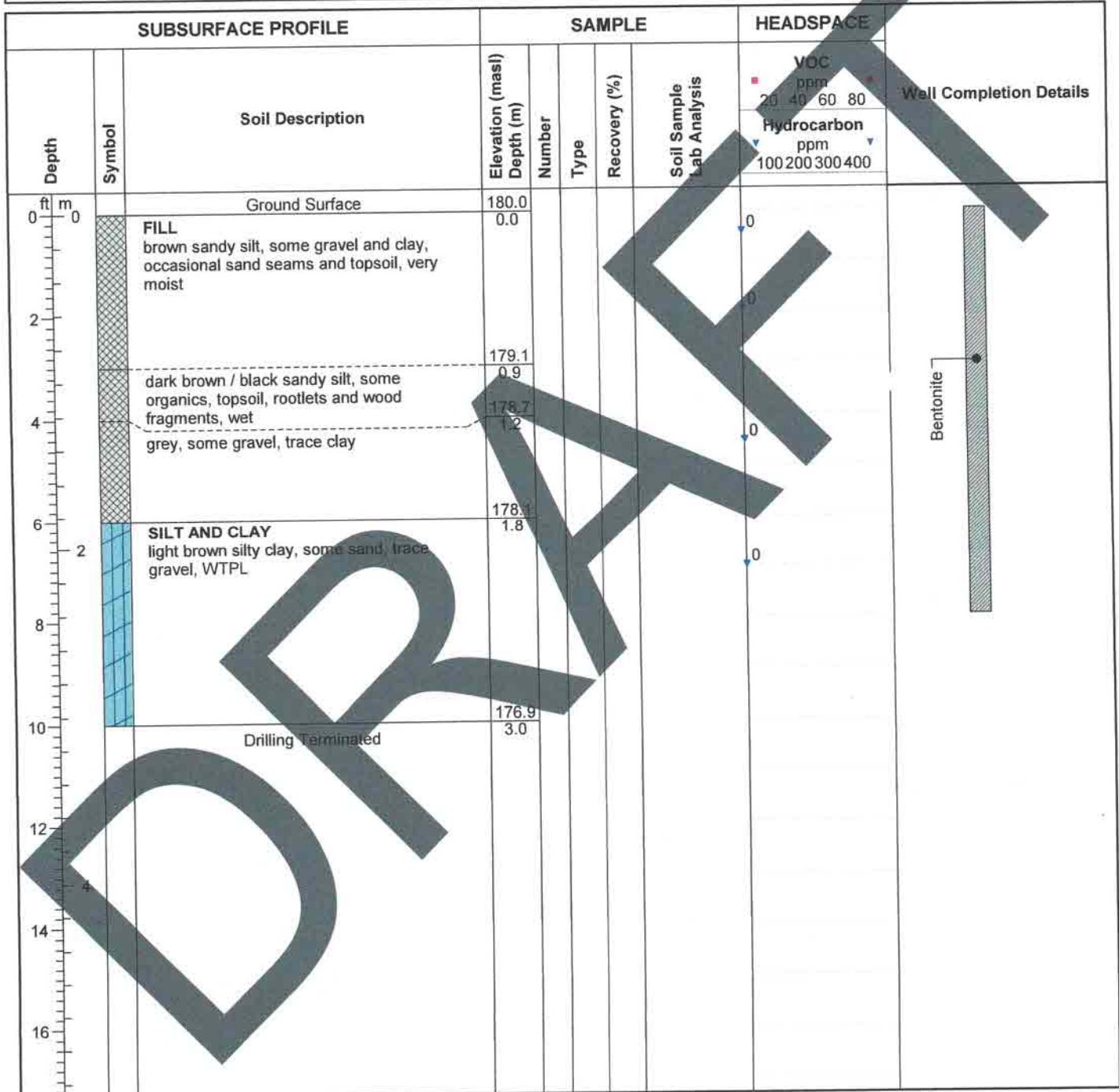

Field Technician: K. Maddock

Drafted by: S. Rederer

Reviewed by: R. Fedy



ID Number: BH213-18

Project: Fox Street, Penetanguishene Development

Project No: 43022-100

Client: Wilmington Capital Management Inc.

Site Location: 160 - 200 Fox Street, Penetanguishene, ON

Drill Date: 4/10/2018

Drilling Contractor: Direct Environmental Drilling

Drill Rig: Geoprobe 7822DT

Drill Method: Direct Push

Protective Cover: N/A

SUBSURFACE PROFILE			SAMPLE				HEADSPACE	Well Completion Details
Depth	Symbol	Soil Description	Elevation (masl) Depth (m)	Number	Type	Recovery (%)	Soil Sample Lab Analysis	
0		Ground Surface	182.1					VOC ppm 20 40 60 80 Hydrocarbon ppm 100 200 300 400
0		FILL brown fine sand and silt, some organics, wet	0.0					
2								
4								
4.5		gravelly, some grey clay pockets	180.6	1.5				
6								
8								
10								
11.5		Dark brown / black sandy silt, some organics and topsoil, very moist	178.8	3.4				
12		SAND brown silty sand, wet	178.5	3.7				
14		SILT AND CLAY grey silt and clay, some sand, trace gravel, DTPL	177.9	4.3				
15.5		Drilling Terminated	177.5	4.6				

Field Technician: K. Maddock

Drafted by: S. Rederer

Reviewed by: R. Fedy



ID Number: BH214-18

Project: Fox Street, Penetanguishene Development

Project No: 43022-100

Client: Wilmington Capital Management Inc.

Site Location: 160 - 200 Fox Street, Penetanguishene, ON

Drill Date: 4/10/2018

Drilling Contractor: Direct Environmental Drilling

Drill Rig: Geoprobe 7822DT

Drill Method: Direct Push

Protective Cover: N/A

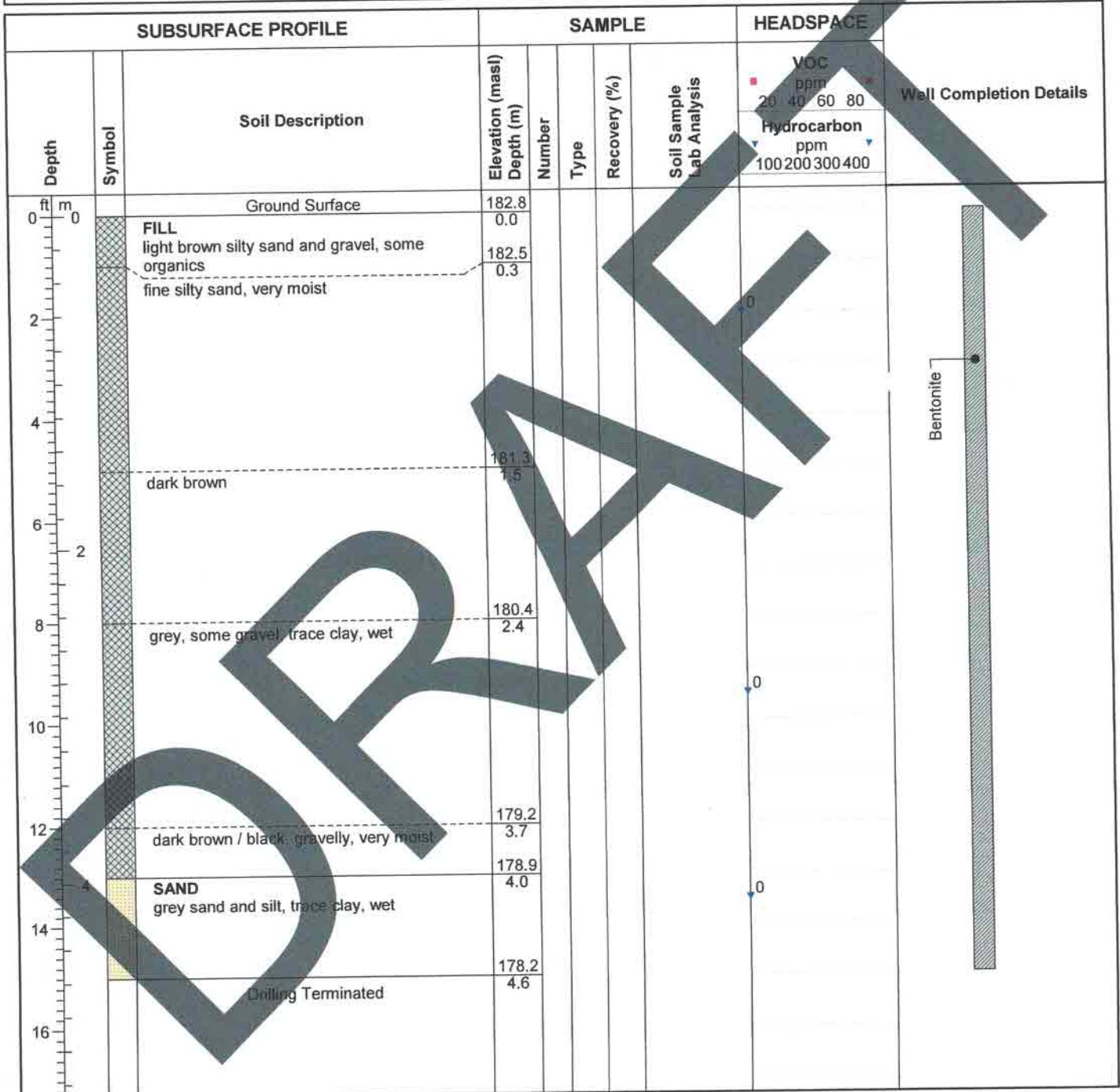

Field Technician: K. Maddock

Drafted by: S. Rederer

Reviewed by: R. Fedy



ID Number: BH215-18

Project: Fox Street, Penetanguishene Development

Project No: 43022-100

Client: Wilmington Capital Management Inc.

Site Location: 160 - 200 Fox Street, Penetanguishene, ON

Drill Date: 4/10/2018

Drilling Contractor: Direct Environmental Drilling

Drill Rig: Geoprobe 7822DT

Drill Method: Direct Push

Protective Cover: N/A

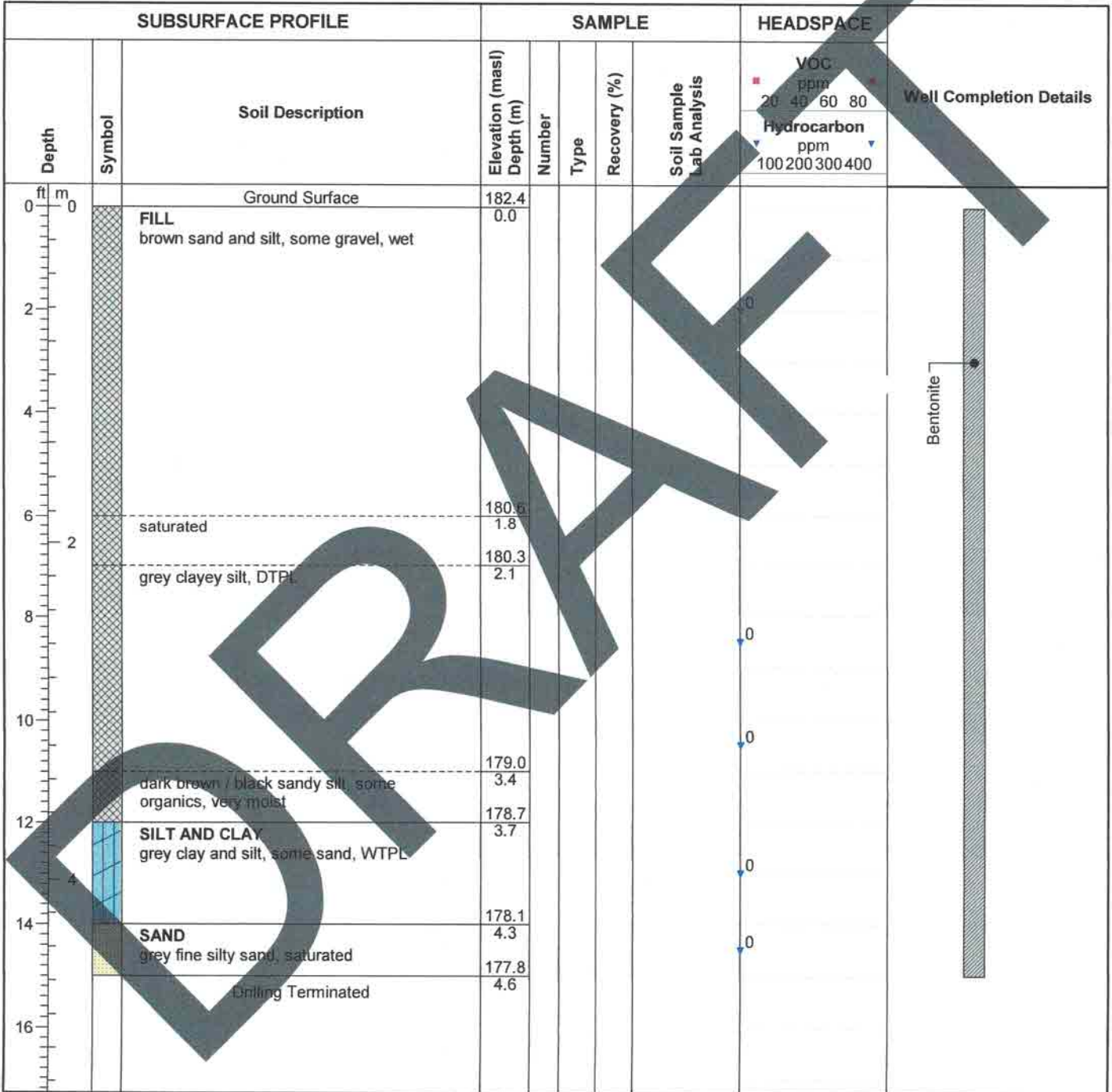

Field Technician: K. Maddock

Drafted by: S. Rederer

Reviewed by: R. Fedy



ID Number: BH216-18

Project: Fox Street, Penetanguishene Development

Project No: 43022-100

Client: Wilmington Capital Management Inc.

Site Location: 160 - 200 Fox Street, Penetanguishene, ON

Drill Date: 4/9/2018

Drilling Contractor: Direct Environmental Drilling

Drill Rig: Geoprobe 7822DT

Drill Method: Hollow Stem Augers

Protective Cover: N/A

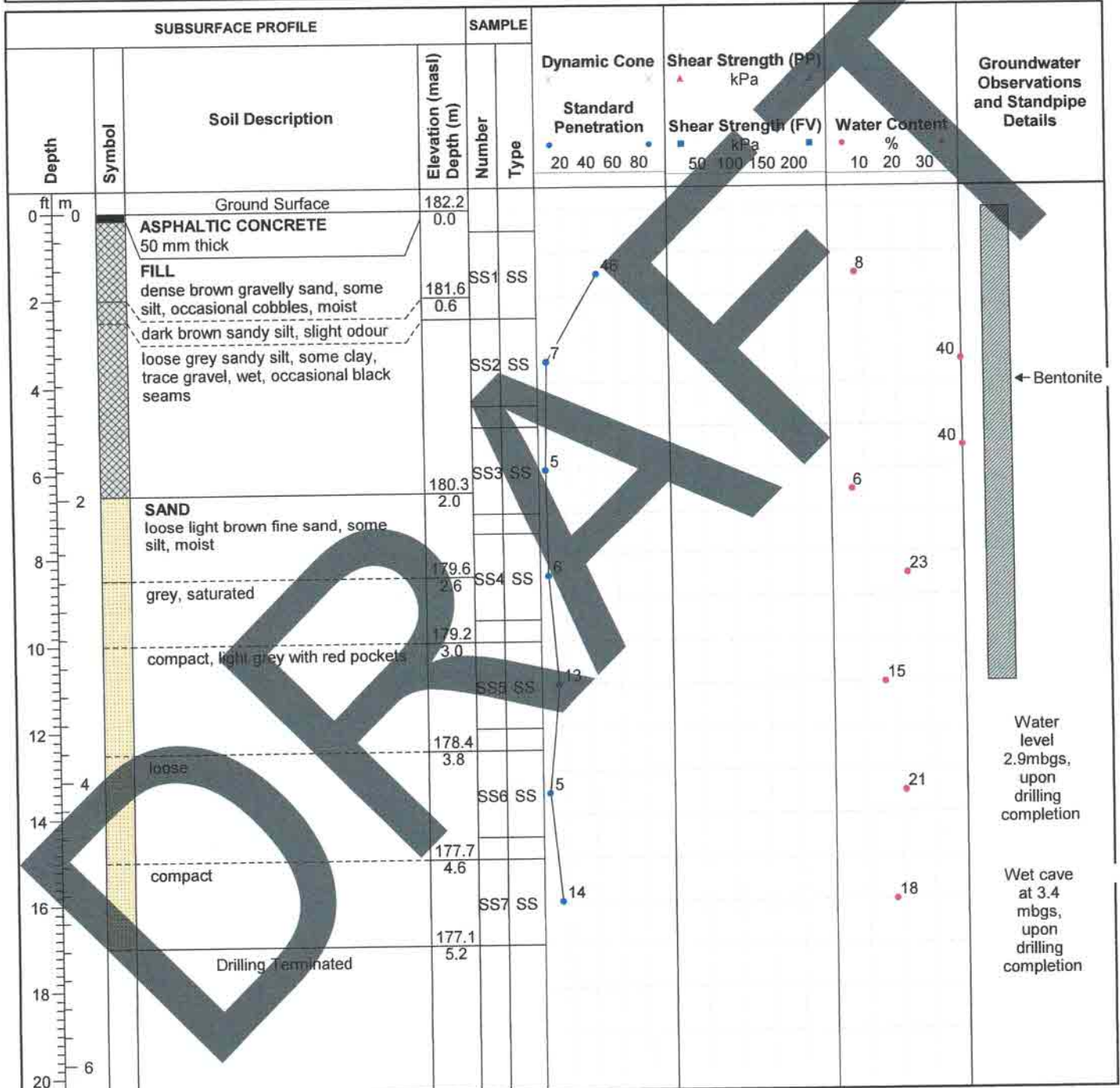

Field Technician: M. Dalglish

Drafted by: B. Heinbuch

Reviewed by: M. Wilson



Sheet: 1 of 1

Notes: Auger refusal on suspected cobble at depth 0.6m, borehole moved 1.5 m west

ID Number: BH217-18

Project: Fox Street, Penetanguishene Development

Project No: 43022-100

Client: Wilmington Capital Management Inc.

Site Location: 160 - 200 Fox Street, Penetanguishene, ON

Drill Date: 4/9/2018

Drilling Contractor: Direct Environmental Drilling

Drill Rig: Geoprobe 7822DT

Drill Method: Hollow Stem Augers

Protective Cover: N/A

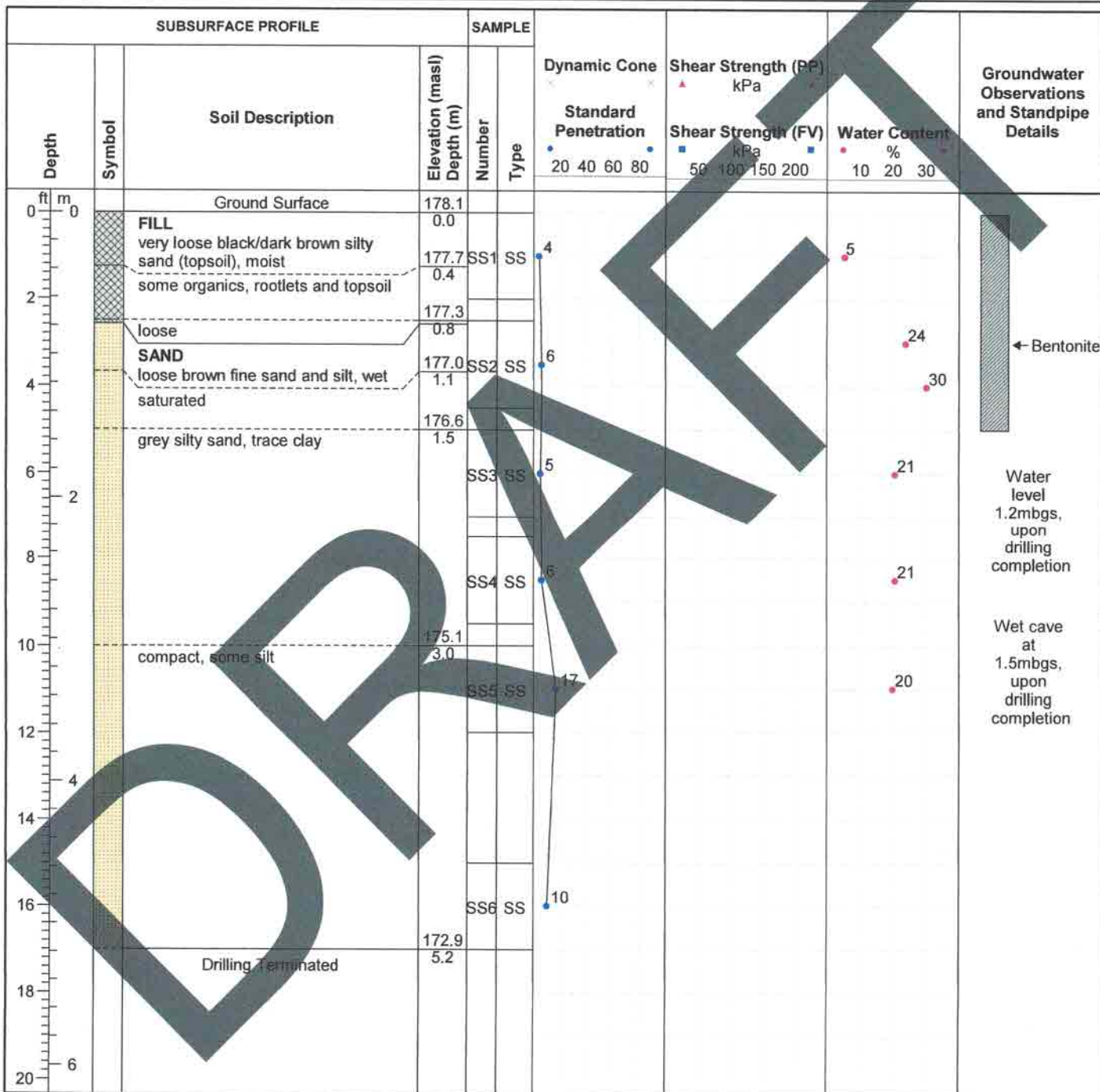

Field Technician: M. Dalgliesh

Drafted by: B. Heinbuch

Reviewed by: M. Wilson



ID Number: BH218-18

Project: Fox Street, Penetanguishene Development

Project No: 43022-100

Client: Wilmington Capital Management Inc.

Site Location: 160 - 200 Fox Street, Penetanguishene, ON

Drill Date: 4/9/2018

Drilling Contractor: Direct Environmental Drilling

Drill Rig: Geoprobe 7822DT

Drill Method: Hollow Stem Augers

Protective Cover: N/A

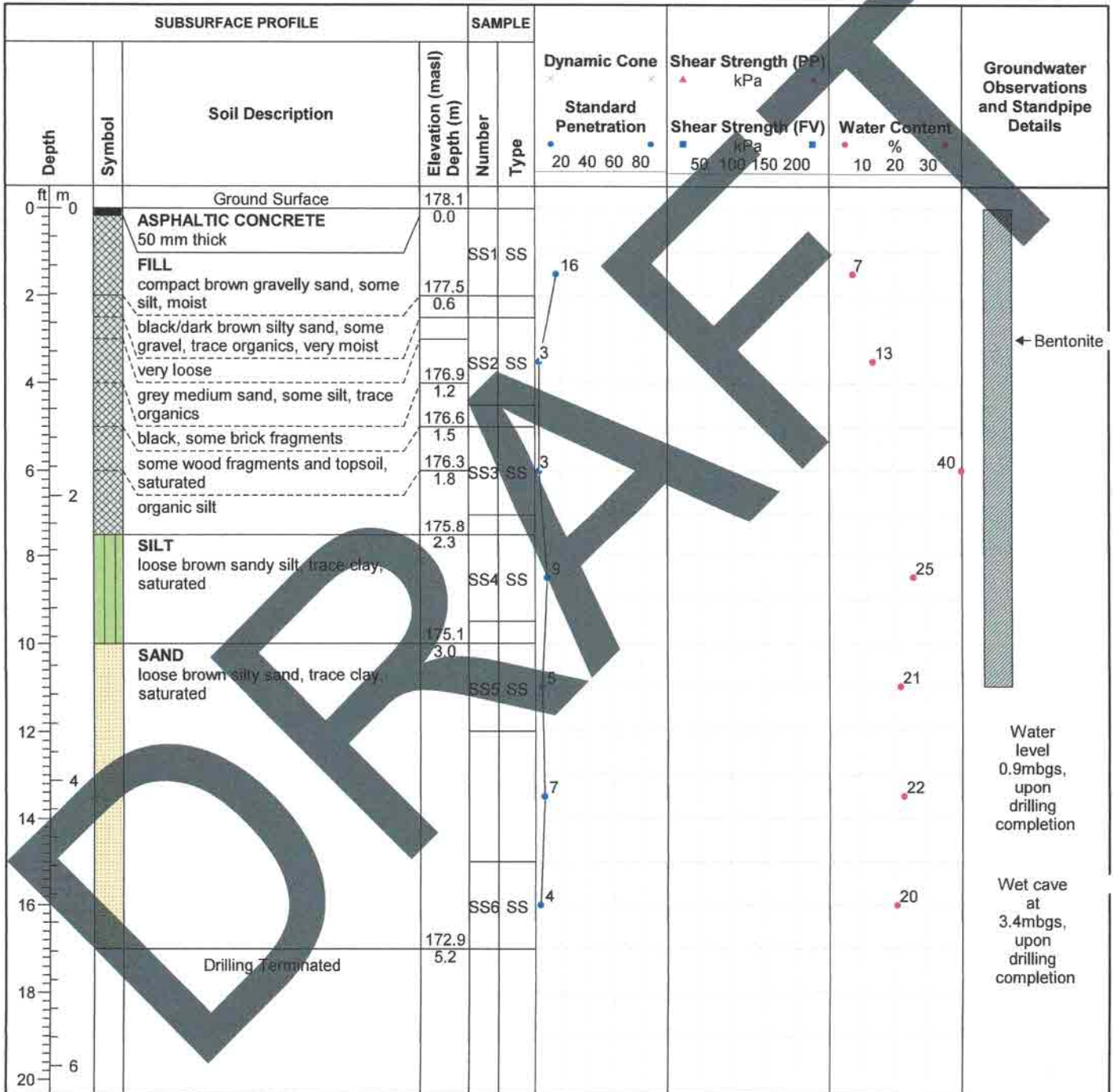

Field Technician: M. Dalgliesh

Drafted by: B. Heinbuch

Reviewed by: M. Wilson



ID Number: BH219-18

Project: Fox Street, Penetanguishene Development

Project No: 43022-100

Client: Wilmington Capital Management Inc.

Site Location: 160 - 200 Fox Street, Penetanguishene, ON

Drill Date: 4/9/2018

Drilling Contractor: Direct Environmental Drilling

Drill Rig: Geoprobe 7822DT

Drill Method: Hollow Stem Augers

Protective Cover: N/A

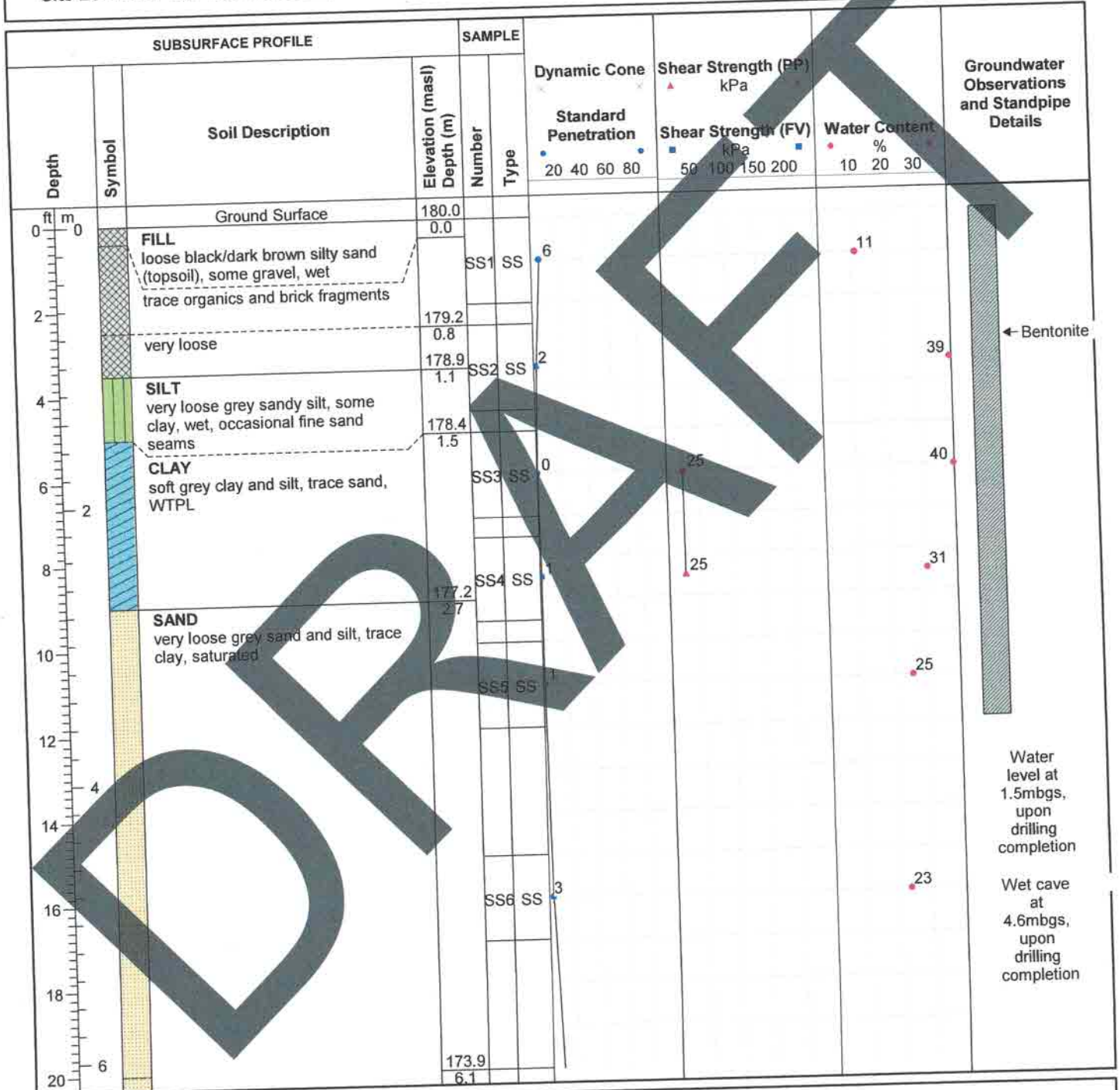

Field Technician: M. Dalgliesh

Drafted by: B. Heinbuch

Reviewed by: M. Wilson



ID Number: BH219-18

Project: Fox Street, Penetanguishene Development

Project No: 43022-100

Client: Wilmington Capital Management Inc.

Site Location: 160 - 200 Fox Street, Penetanguishene, ON

Drill Date: 4/9/2018

Drilling Contractor: Direct Environmental Drilling

Drill Rig: Geoprobe 7822DT

Drill Method: Hollow Stem Augers

Protective Cover: N/A

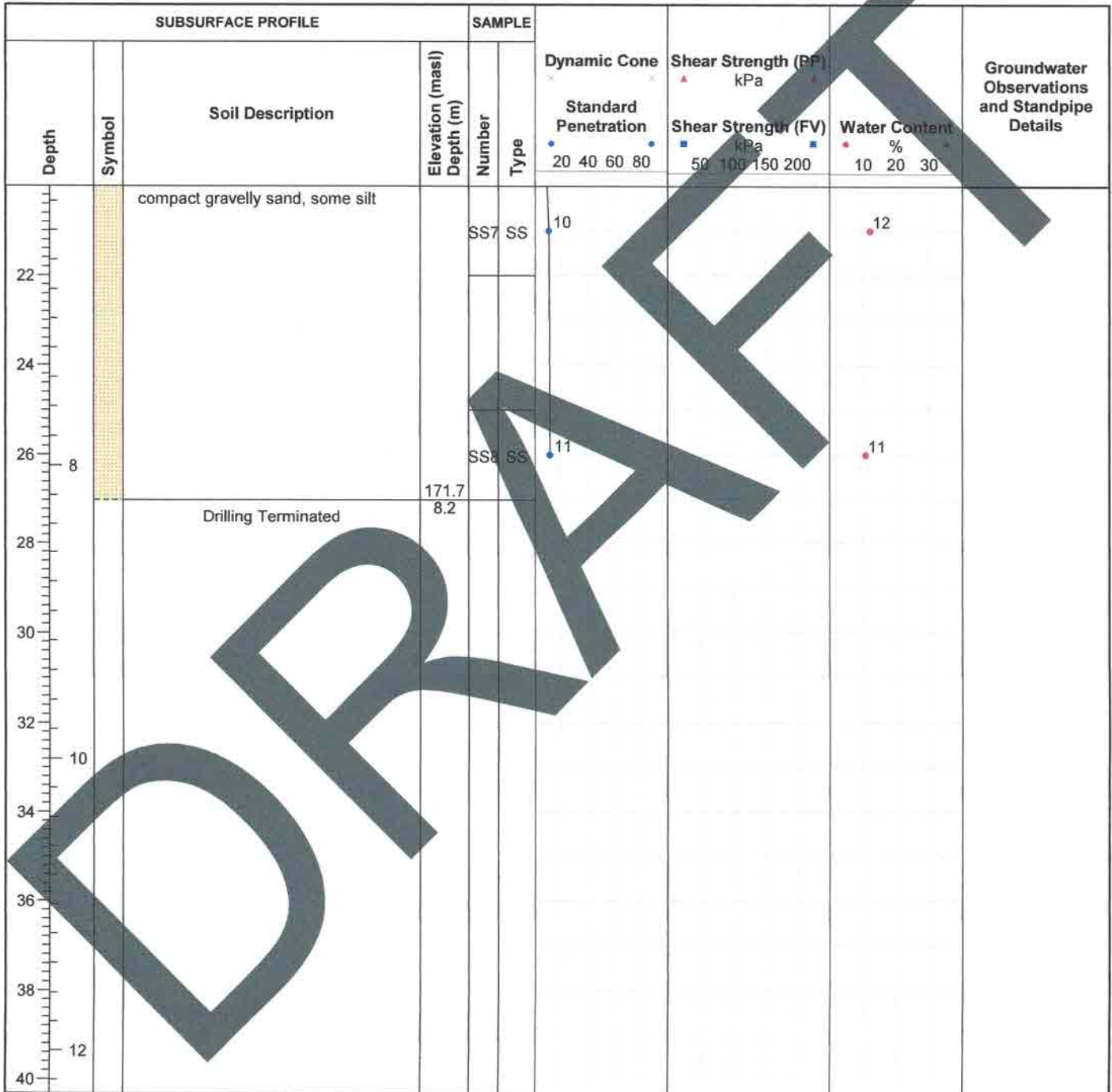

Field Technician: M. Dalgliesh

Drafted by: B. Heinbuch

Reviewed by: M. Wilson



ID Number: BH220-18

Project: Fox Street, Penetanguishene Development

Project No: 43022-100

Client: Wilmington Capital Management Inc.

Site Location: 160 - 200 Fox Street, Penetanguishene, ON

Drill Date: 4/9/2018

Drilling Contractor: Direct Environmental Drilling

Drill Rig: Geoprobe 7822DT

Drill Method: Hollow Stem Augers

Protective Cover: N/A

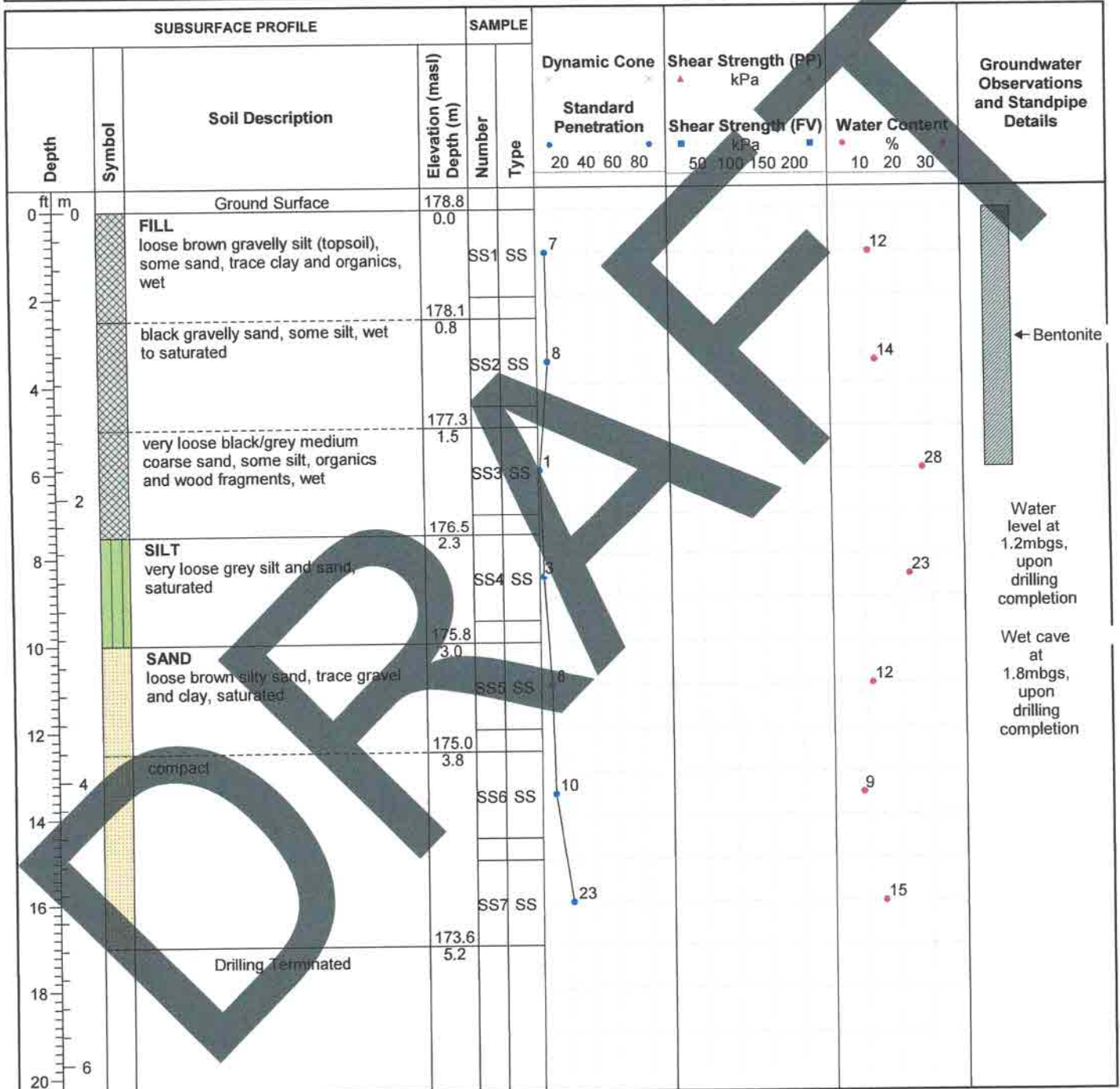

Field Technician: M. Dalglish

Drafted by: B. Heinbuch

Reviewed by: M. Wilson



LABORATORY TEST RESULTS

Table 1 – Particle Size Distribution Analyses
Table 2 – Grain Size Distribution Analysis

DRAFT



Particle Size Distribution Analysis Test Results

PROJECT NAME: Fox Street Penetanguishene
 CLIENT: Wilmington Capital Inc.

DATE SAMPLED: Apr. 9, 2018
 DATE TESTED: Apr. 24-27, 2018

FILE No.: 43022-100
 TABLE #: 1

Unified Soil Classification

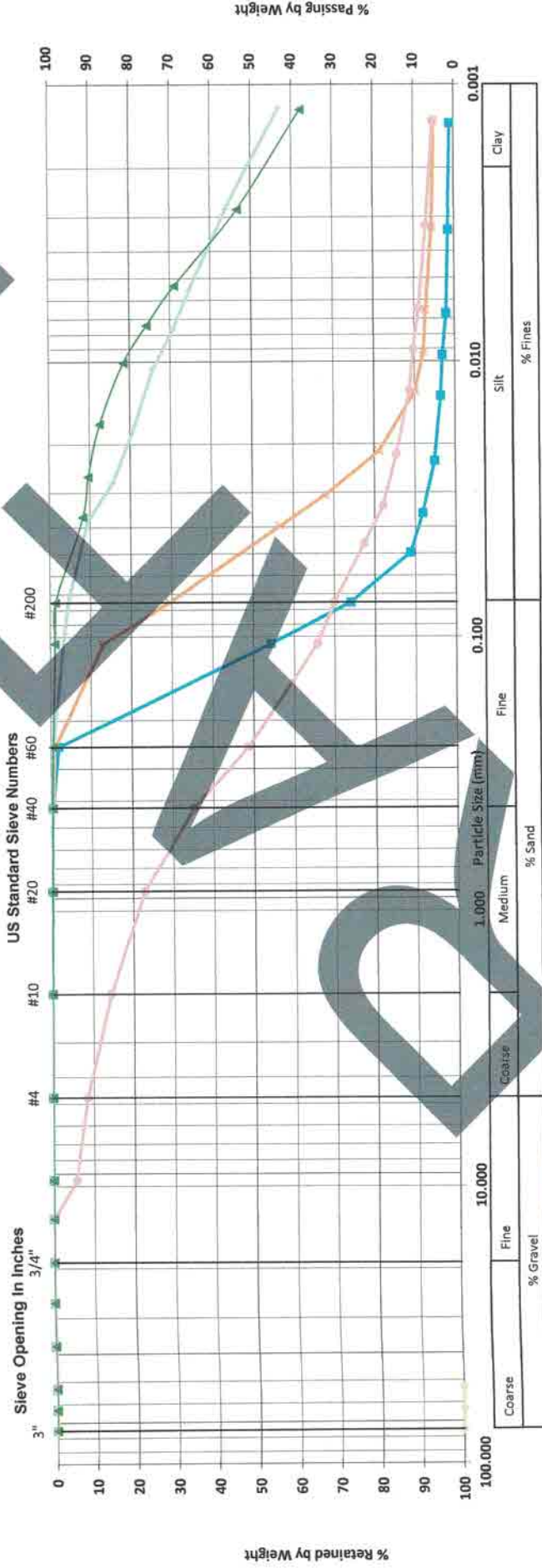

Symbol	Borehole ID	Sample #	Sample Depth	Description
■	BH217-18	SS-5	3.05 - 3.66 mbgs	SILT and CLAY, trace Sand
■	BH218-18	SS-3	1.52 - 2.13 mbgs	Silty SAND, trace Clay
■	BH219-18	SS-4	2.29 - 2.90 mbgs	Sandy SILT, trace Clay
■	BH220-18	SS-3	1.52 - 2.13 mbgs	CLAY and SILT, trace Sand
■	BH220-18	SS-5	3.05 - 3.66 mbgs	Silty SAND, trace Gravel and Clay



NOTES:

MTE Consultants Inc.
 365 Home Street
 Stratford, Ontario N5A 2A5
 Phone: 519-271-7952
 Fax: 519-271-3545

www.mte85.com

PROJECT NAME: Fox Street Penetanguishene

CLIENT: Wilmington Capital Inc.

FILE NO.: 43022-100

DATE: April 10, 2018

DATE SAMPLED: April 9, 2018

LAB NO.: S90G

BOREHOLE ID: BH216-18

DATE TESTED: April 23, 2018

SAMPLE INFO: SS-7 4.57-5.18mbgs

TESTED BY: M.Dalgliesh

TABLE NO.: 2

SIEVE ANALYSIS OF AGGREGATE

SIEVE SIZE (mm)	% PASSING
150	100.0
100	100.0
63.0	100.0
53.0	100.0
37.5	100.0
26.5	100.0
22.0	100.0
19.0	100.0
16.0	100.0
13.2	100.0
9.50	100.0
6.75	100.0
4.75	100.0
2.36	99.7
1.18	98.4
0.600	85.7
0.300	33.4
0.150	5.1
0.075	1.7

NOTES:



**TENSAR INTERNATIONAL CORPORATION
PRODUCT INFORMATION**

DRAFT



DESIGN PARAMETERS

DESIGN REQUIREMENTS

Property	Value
Axle Load (kN)	80
Tire Pressure (kPa)	552
Axle Passes (Each)	12000
Maximum Rut Depth (mm)	40

PAVEMENT SOIL PROPERTIES

Property	Value
Aggregate Fill CBR (%)	20
Soaked Subgrade CBR (%)	0.8

Aggregate fill shall conform to following requirement:
D50 <= 27mm

RESULTS

Geosynthetic	Aggregate Fill Thickness (mm)		Aggregate Fill Thickness Savings (mm)	
	Calculated	Required	(mm)	(%)
Unstabilized	840.9	850	N/A	N/A
TX140	509.0	510	340	40
TX160	403.1	410	440	52

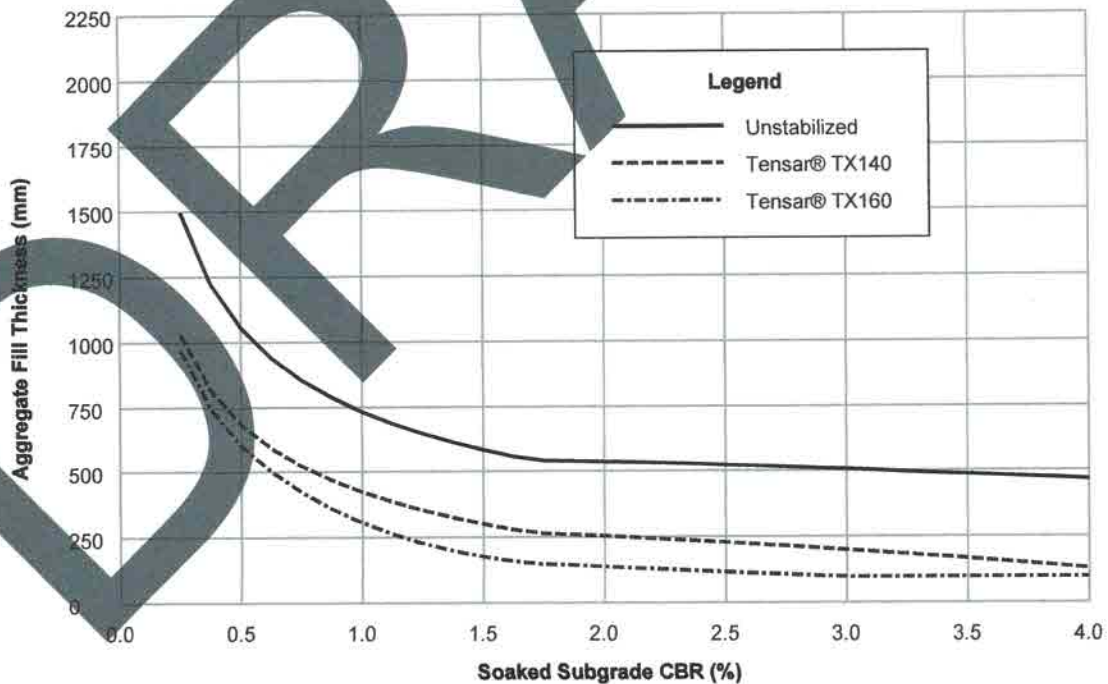

Project Name	Fox Street, Penetanguishene		
Company Name	MTE		
Designer		Date	

Product Specification - TriAx® TX140 Geogrid

Tensor International Corporation reserves the right to change its product specifications at any time. It is the responsibility of the person specifying the use of this product and of the purchaser to ensure that product specifications relied upon for design or procurement purposes are current and that the product is suitable for its intended use in each instance.

Tensor TriAx® Geogrid

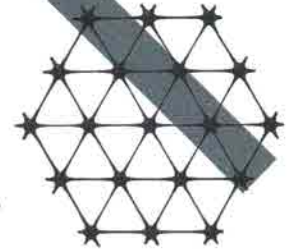

General

1. The geogrid is manufactured from a punched polypropylene sheet, which is then oriented in three substantially equilateral directions so that the resulting ribs shall have a high degree of molecular orientation, which continues at least in part through the mass of the integral node.
2. The properties contributing to the performance of a mechanically stabilized layer include the following:

Index Properties

	Longitudinal	Diagonal	Transverse	General
▪ Rib pitch ⁽²⁾ , mm (in)	40 (1.60)	40 (1.60)	-	
▪ Mid-rib depth ⁽²⁾ , mm (in)	-	1.2 (0.05)	1.2 (0.05)	
▪ Mid-rib width ⁽²⁾ , mm (in)	-	1.1 (0.04)	1.1 (0.04)	
▪ Rib shape				rectangular
▪ Aperture shape				triangular

Structural Integrity

▪ Junction efficiency ⁽³⁾ , %				93
▪ Aperture stability ⁽⁴⁾ , kg-cm/deg @ 5.0kg-cm ⁽²⁾				3.0
▪ Radial stiffness at low strain ⁽⁵⁾ , kN/m @ 0.5% strain (lb/ft @ 0.5% strain)				225 (15,430)

Durability

▪ Resistance to chemical degradation ⁽⁶⁾				100%
▪ Resistance to ultra-violet light and weathering ⁽⁷⁾				100%

Dimensions and Delivery

The TX Geogrid shall be delivered to the jobsite in roll form with each roll individually identified and nominally measuring 3.0 meters (9.8 feet) and/or 4.0 meters (13.1 feet) in width and 75 meters (246 feet) in length.

Notes

1. Unless indicated otherwise, values shown are minimum average roll values determined in accordance with ASTM D4759-02. Brief descriptions of test procedures are given in the following notes.
2. Nominal dimensions.
3. Load transfer capability determined in accordance with GRI-GG2-87 and GRI-GG1-87 and expressed as a percentage of ultimate tensile strength.
4. In-plane torsional rigidity measured by applying a moment to the central junction of a 225mm x 225mm specimen restrained at its perimeter in accordance with GRI-GG9 modified.
5. Radial stiffness is determined from tensile stiffness measured in any in-plane axis from testing in accordance with ASTM D6637-10.
6. Resistance to loss of load capacity or structural integrity when subjected to chemically aggressive environments in accordance with EPA 9090 immersion testing.
7. Resistance to loss of load capacity or structural integrity when subjected to 500 hours of ultraviolet light and aggressive weathering in accordance with ASTM D4355-05.

Tensor International Corporation
2500 Northwinds Parkway, Suite 500
Alpharetta, Georgia 30009

Phone: 800-TENSAR-1
www.tensor-international.com

This specification supersedes any and all prior specifications for the product designated above and is not applicable to any product shipped prior to February 1, 2011. Tensor and TriAx are trademarks of Tensor International Corporation or its affiliates in the US and many other countries. TriAx® geogrid and the use thereof are protected by U.S. Patent No. 7,001,112. Patents or patent applications also exist in other countries. Final determination of the suitability of the above-mentioned information or product for the use contemplated, and its manner of use are the sole responsibility of the user. Tensor International Corporation disclaims any and all express, implied or statutory warranties, including but not limited to, any warranty of merchantability or fitness for a particular purpose regarding this product or the Company's other products, technologies or services. The information contained herein does not constitute engineering advice.

Product Specification - TriAx® TX160 Geogrid

Tensor International Corporation reserves the right to change its product specifications at any time. It is the responsibility of the person specifying the use of this product and of the purchaser to ensure that product specifications relied upon for design or procurement purposes are current and that the product is suitable for its intended use in each instance.

Tensor TriAx® Geogrid

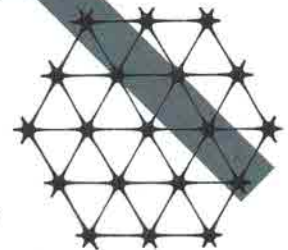

General

- The geogrid is manufactured from a punched polypropylene sheet, which is then oriented in three substantially equilateral directions so that the resulting ribs shall have a high degree of molecular orientation, which continues at least in part through the mass of the integral node.
- The properties contributing to the performance of a mechanically stabilized layer include the following:

Index Properties

	Longitudinal	Diagonal	Transverse	General
▪ Rib pitch ⁽²⁾ , mm (in)	40 (1.60)	40 (1.60)	-	
▪ Mid-rib depth ⁽²⁾ , mm (in)	-	1.6 (0.06)	1.4 (0.06)	
▪ Mid-rib width ⁽²⁾ , mm (in)	-	1.0 (0.04)	1.2 (0.05)	
▪ Rib shape				rectangular
▪ Aperture shape				triangular

Structural Integrity

▪ Junction efficiency ⁽³⁾ , %				93
▪ Aperture stability ⁽⁴⁾ , kg-cm/deg @ 5.0kg-cm ⁽²⁾				3.6
▪ Radial stiffness at low strain ⁽⁵⁾ , kN/m @ 0.5% strain (lb/ft @ 0.5% strain)				300 (20,580)

Durability

▪ Resistance to chemical degradation ⁽⁶⁾				100%
▪ Resistance to ultra-violet light and weathering ⁽⁷⁾				100%

Dimensions and Delivery

The TX Geogrid shall be delivered to the jobsite in roll form with each roll individually identified and nominally measuring 3.0 meters (9.8 feet) and/or 4.0 meters (13.1 feet) in width and 75 meters (246 feet) in length.

Notes

- Unless indicated otherwise, values shown are minimum average roll values determined in accordance with ASTM D4759-02. Brief descriptions of test procedures are given in the following notes.
- Nominal dimensions.
- Load transfer capability determined in accordance with GRI-GG2-87 and GRI-GG1-87 and expressed as a percentage of ultimate tensile strength.
- In-plane torsional rigidity measured by applying a moment to the central junction of a 225mm x 225mm specimen restrained at its perimeter in accordance with GRI-GG9 modified.
- Radial stiffness is determined from tensile stiffness measured in any in-plane axis from testing in accordance with ASTM D6637-10.
- Resistance to loss of load capacity or structural integrity when subjected to chemically aggressive environments in accordance with EPA 9090 immersion testing.
- Resistance to loss of load capacity or structural integrity when subjected to 500 hours of ultraviolet light and aggressive weathering in accordance with ASTM D4355-05.

Tensor International Corporation
2500 Northwinds Parkway, Suite 500
Alpharetta, Georgia 30009

Phone: 800-TENSAR-1
www.tensor-international.com

This specification supersedes any and all prior specifications for the product designated above and is not applicable to any product shipped prior to February 1, 2011. Tensor and TriAx are trademarks of Tensor International Corporation or its affiliates in the US and many other countries. TriAx® geogrid and the use thereof are protected by U.S. Patent No. 7,001,112. Patents or patent applications also exist in other countries. Final determination of the suitability of the above-mentioned information or product for the use contemplated, and its manner of use are the sole responsibility of the user. Tensor International Corporation disclaims any and all express, implied or statutory warranties, including but not limited to, any warranty of merchantability or fitness for a particular purpose regarding this product or the Company's other products, technologies or services. The information contained herein does not constitute engineering advice.

Geogrid Specifications

Provisional use of Geogrids for Subgrade Stabilization

Geogrid shall be Tensar TX140 or TX160 as manufactured by Tensar International and supplied by Terrafix Geosynthetics. Material selection and design for the Mechanically Stabilized Layer shall be carried out as follows:

The Mechanical Stabilized Layer shall be designed in accordance with the Giroud-Han Method (Giroud and Han, 2004) of unpaved road design.

Approved Alternatives:

In-air index testing of geogrid properties, or explanation of performance based on in-air index testing of geogrid properties are not sufficient to understand the complex mechanisms involved in soil-geogrid interaction and/or the performance of Mechanically Stabilized Layers. Therefore, no acceptance of alternates based on material index property comparisons or explanations of performance based on in-air testing of geogrid properties will be allowed.

Any submittal for an alternative Mechanically Stabilized Layer design must be submitted at least 2 weeks in advance of the bid date and must be accompanied with the following:

- A design signed and sealed by a professional engineer registered to practice in the Province of Ontario.
- Unpaved design- A written statement from the alternative Mechanically Stabilized Layer design engineer of record that the design is based upon the Giroud-Han Method and that proper calibration and validation testing has been performed for the geogrid reinforcement utilized in the Mechanically Stabilized Layer in accordance with these specifications.
- A submittal package that includes documented evidence of proper calibration and validation testing.



**EBS GEOSTRUCTURAL INC.
HELICAL PILE INFORMATION**

DRAFT

DISCLAIMER

- The information and sketches contained in these drawings are given as guidelines only.
- Capacities of Chance Helical Piers/Anchors may vary depending on, but not limited to, water table elevation and changes to that elevation, changing soil conditions, soil layer thickness.
- Achievable capacities could be higher or lower than rolings due to site-specific conditions. On site load testing should be performed to confirm additional pile/anchor capacities.
- Installed capacities to be verified on site by a registered Professional Engineer.
- The information contained herein is to be used for preliminary design activities only, and subject to EBS' Website Disclaimer.

TWIN & TRIPLE SS5 HELICAL PIERS / ANCHORS



HELIX MUST BE FORMED BY MATCHING METAL DIE (SIDE VIEW OF TRUE HELICAL FORM)

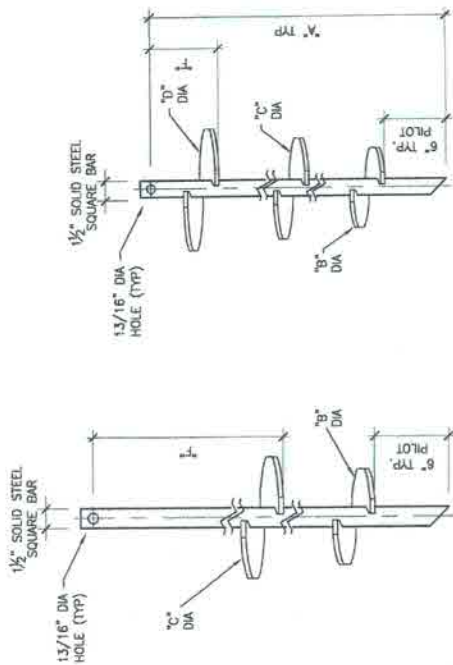

LEAD SECTION

SCALE: N.T.S.

LEAD SECTION			
"A"	"B"	"C"	"D"
82-1/4"	6"	8"	10-3/4"
82-1/4"	8"	10"	12-1/4"
82-1/4"	10"	12"	14-1/4"
63-1/4"	8"	10"	12-3/4"
82-1/4"	10"	12"	14-3/4"

NOTES

- HOT DIP GALVANIZED PER ASTM A153-(LATEST REV.)
- SMALL MATERIALS NOT ROLLED ROUND-CORNERED SQUARE (RCS) SOLID STEEL BARS PER ASTM A283; MINIMUM TENSILE STRENGTH=70 KSI
- HEAVY METAL -HOT ROLLED LOW CARBON STEEL SHEET, STRIP, OR PLATE PER ASTM A572, OR A572M, OR A572S; MINIMUM YIELD STRENGTH=50 KSI; 3/8" THICK
- CORNER ROUNDS: 3/16" DIAMETER X 3" LONG HEX HEAD PER ASTM A320 GRADE L7.
- MINIMAL SPACING BETWEEN HELICAL PLATES IS THREE TIMES THE DIAMETER OF THE LOWER HELIX.
- MANUFACTURERS MUST HAVE IN EFFECT INDUSTRY RECOGNIZED WRITTEN QUALITY CONTROL FOR ALL MATERIALS AND MANUFACTURING PROCESSES.
- ALL WELDING TO BE COMPLETED BY WELDERS CERTIFIED UNDER SECTION 5 OF THE AWS CODE D1.1.
- ALL HELICES HAVE TO BE SPACED LEADING EDGE.
- TORQUE STRENGTH RATING: 55 KIP-FT-1B.
- TORQUE CAPACITY (TENSION/COMPRESSION)-55 KIP, BASED ON A TORQUE FACTOR (Kt)=10.
- ULTIMATE TENSION STRENGTH (TENSION/COMPRESSION BOLT)-70 KIP.

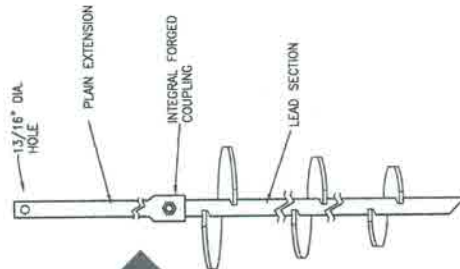

TYPICAL PIER / ANCHOR ASSEMBLY

SCALE: N.T.S.

PLAIN EXTENSION

SCALE: N.T.S.

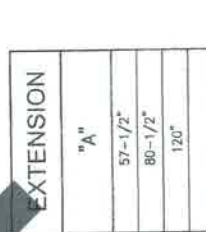

PLAIN EXTENSION

PLAIN EXTENSION	
"A"	EXTENSION
57-1/2"	120"
80-1/2"	120"
120"	120"

LEAD SECTION

LEAD SECTION			
"A"	"B"	"C"	"D"
82-1/4"	6"	8"	10-3/4"
82-1/4"	8"	10"	12-1/4"
82-1/4"	10"	12"	14-1/4"
63-1/4"	8"	10"	12-3/4"
82-1/4"	10"	12"	14-3/4"

SCALE: N.T.S.

EBS
GEOSTEEL

320 Wabash Street South, Bristol, Ohio 45808 UMC
Tel: 614-648-8013 Fax: 614-648-2526
Email: ebs@geosteel.com

PROJECT: SAMPLE

DRAWING: SS5 HELICAL PIERS / ANCHORS

DRAWN BY: SCALE: N.T.S.

CHECKED: DATE: NOVEMBER 2012

PROJECT No.: DWG. No.:

EBS is an authorized distributor of A.B. Chance Civil Construction products.

CHANGE
Since 1912

Registered trademark of A. B. Chance, a division of Hubbell Power Systems, Inc.

DISCLAIMER

1. The information and sketches contained in these drawings are given as guidelines only. Capacities of Chance Helical Piles/Anchors may vary depending on, but not limited to, water table elevation and changes to that elevation, changing soil conditions, soil layer thicknesses.
2. Achievable capacities could be higher or lower than ratings due to site-specific conditions. On site load testing should be performed to confirm additional pile/anchor capacities.
3. Installed capacities to be verified on site by a registered Professional Engineer.
4. The information contained herein is to be used for preliminary design activities only, and subject to EBS' Website Disclaimer.

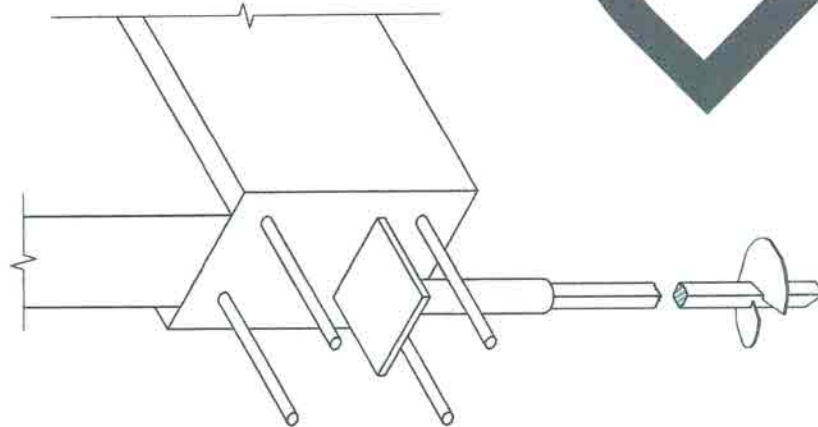

INSTALLATION CONCEPT OF
PIER CAP DETAIL

SCALE: N.T.S.

NEW CONSTRUCTION BRACKET

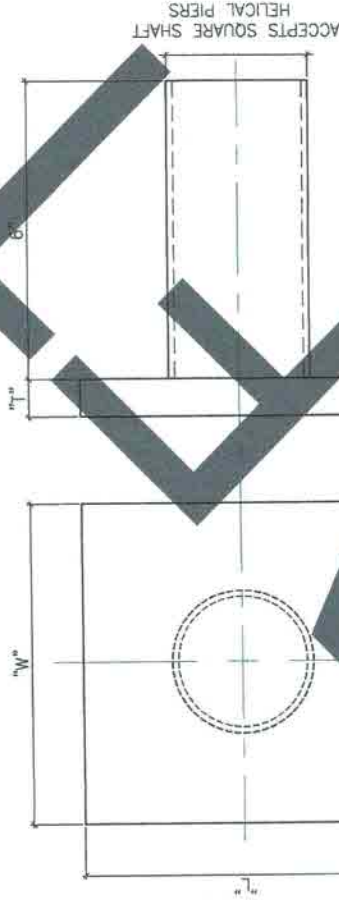

**NEW CONSTRUCTION
BRACKET**

SCALE: N.T.S.

NEW CONSTRUCTION BRACKET SIZES

HELICAL SS TYPE	"L"	"W"	"t"	SERVICE LOAD RATING
SSS	6"	6"	1/2"	25 KIP
SS175	6-1/2"	6-1/2"	3/4"	55 KIP
SS300	8"	8"	1"	80 KIP
SS375	9"	9"	1"	100 KIP

NOTES

1. FINISH: MILL FINISH STEEL.
2. PIPE: STEEL TUBE, ROUND, PER ASTM A500 GRADE B OR EQUIVALENT.
3. PLATE: PER ASTM A36 OR EQUIVALENT.
4. RATING: RATING IS VALID ONLY IF THE PIER CAP DETAIL HAS BEEN DESIGNED TO ENSURE ADEQUATE LOAD TRANSFER FROM REINFORCED CONCRETE FOUNDATION TO HELICAL PIER, AND IN ACCORDANCE WITH EXISTING LOCAL CODE REQUIREMENTS AND /OR ESTABLISHED LOCAL PRACTICES.



320 Woodmen Stone Circle, Brinkley, Colorado, 80814 MD
Tel: 970.645.5235
Email: info@ebsgeopro.com

PROJECT:

SAMPLE

DRAWING: NEW CONSTRUCTION BRACKET

SCALE: N.T.S.

CHECKED: DATE: NOVEMBER 2012

PROJECT No.: DWG. No.:

GEOTECHNICAL CAPACITIES OF SQUARE SHAFT HELICAL PILES

SOIL PROPERTIES		PRODUCT TYPE	COMPRESSION CAPACITY		TENSION CAPACITY	
"N" VALUE COHESIVE	"N" VALUE NON-COHESIVE	SQUARE SHAFT SIZE mm (INCHES)	SLS (kN (KIPS))	ULS (kN (KIPS))	SLS (kN (KIPS))	ULS (kN (KIPS))
25-35	25-30	* SS5 38 (1.5)	200 (45)	270 (60)	60 (13)	80 (18)
35-45	30-35	SS175 44 (1.75)	370 (83)	500 (113)	135 (30)	150 (33)
50-60	40-50	SS200 51 (2)	500 (112)	670 (150)	165 (37)	215 (48)
65-100	55-100	SS225 57 (2.25)	680 (153)	915 (206)	240 (54)	310 (70)

* Ability to install with light access (3ft wide) and low headroom (6ft high)

GEOTECHNICAL CAPACITIES OF ROUND SHAFT HELICAL PILES

SOIL PROPERTIES		PRODUCT TYPE	COMPRESSION CAPACITY		TENSION CAPACITY	
"N" VALUE COHESIVE	"N" VALUE NON- COHESIVE	DIAMETER mm (INCHES)	SLS kN (KIPS)	ULS kN (KIPS)	SLS kN (KIPS)	ULS kN (KIPS)
20-25	15-20	* RS2875 73 (2.875)	115 (25)	155 (35)	50 (11)	65 (15)
25-30	20-25	RS3500 89 (3.5)	210 (47)	280 (64)	90 (20)	120 (27)
30-35	25-30	RS4500 114 (4.5)	320 (72)	430 (97)	135 (31)	185 (42)
35-40	30-35	RS6625 168 (6.625)	460 (104)	620 (140)	200 (45)	270 (60)
40-45	35-40	RS8625 219 (8.625)	690 (156)	930 (210)	300 (67)	400 (90)
45-50	40-45	RS958 244 (9.625)	950 (214)	1300 (293)	480 (108)	650 (146)

* Ability to install in tight access (3ft width) and low headroom (6ft high)



"MTE is a trusted advisor to our clients and enhances their projects by providing the right solution in a personal, cost effective and timely manner."

DRAFT

MTE Consultants Inc.

1016 Sutton Drive, Unit A
Burlington, Ontario L7L 6B8
Phone: 905-639-2552
Fax: 905-639-7727

520 Bingham Centre Drive
Kitchener, Ontario N2B 3X9
Phone: 519-743-6500
Fax: 519-743-6513

560 Wellington Street, Fourth Floor
London, Ontario N6A 3R4
Phone: 519-204-6510
Fax: 519-204-6511

365 Home Street
Stratford, Ontario N5A 2A5
Phone: 519-271-7952
Fax: 519-271-3545

www.mte85.com

APPENDIX D

CORRESPONDENCE

Note:
It is John Brooks' standard practice to add 0.152m to the depth of station requested by the customer.
This is to elevate the top of station above grade by 0.152m and promote drainage of water off the top of the station.

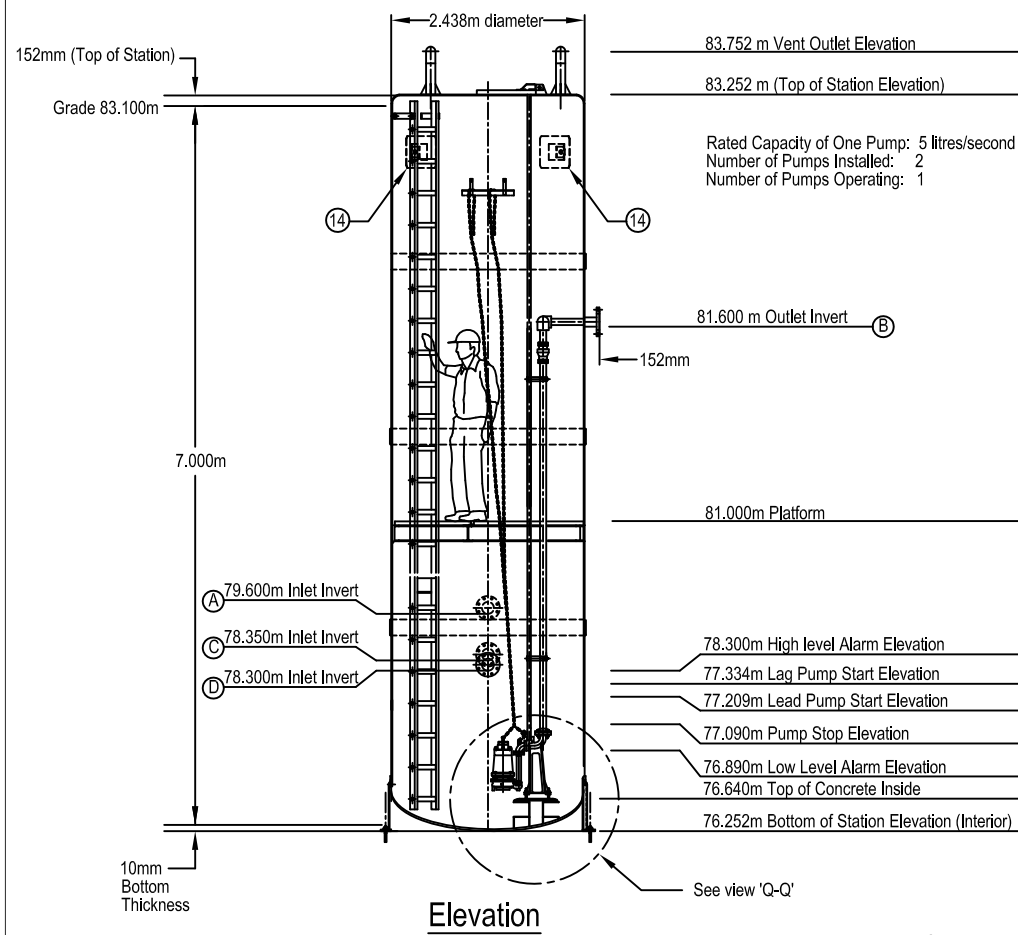

Elevation

Rated Capacity of One Pump: 5 litres/second
Number of Pumps Installed: 2
Number of Pumps Operating: 1

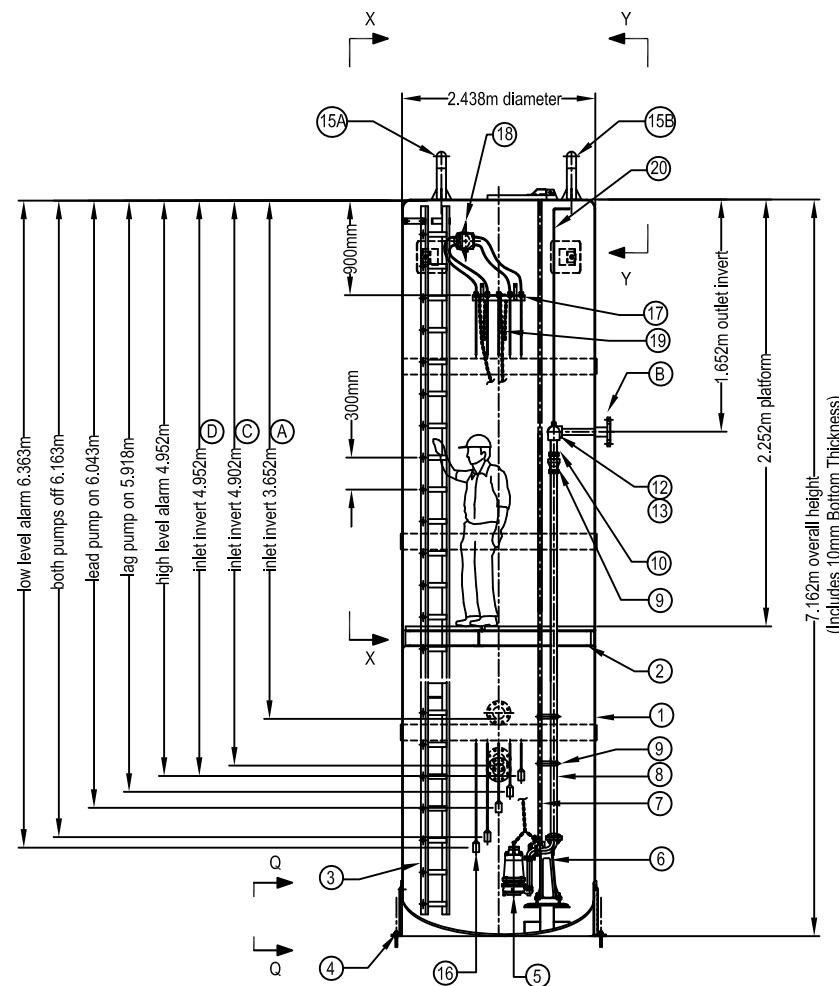

Section A-A (of station)

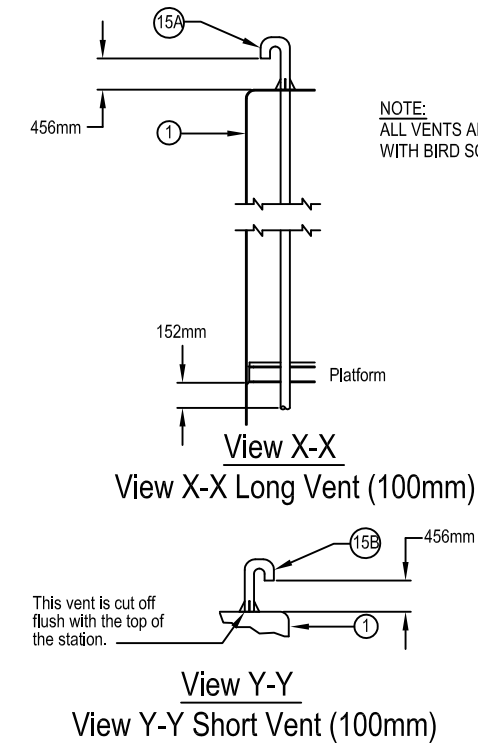

View X-X
View X-X Long Vent (100mm)

View Y-Y
View Y-Y Short Vent (100mm)

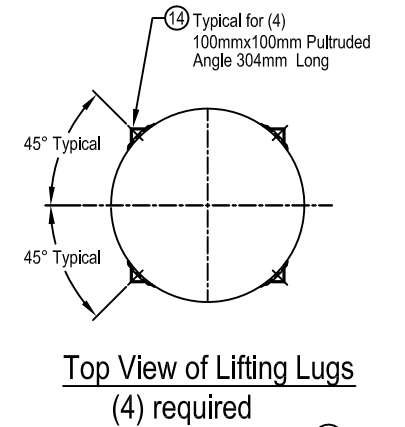

Top View of Lifting Lugs
(4) required

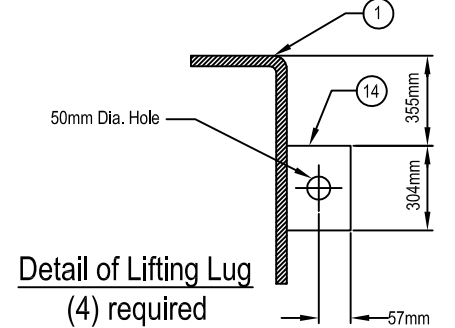

Detail of Lifting Lug
(4) required

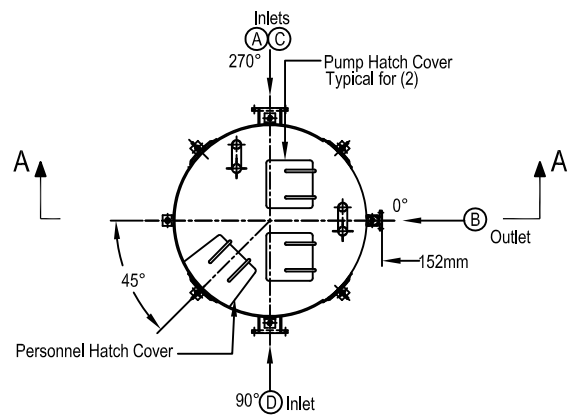

Plan view (at top of station)

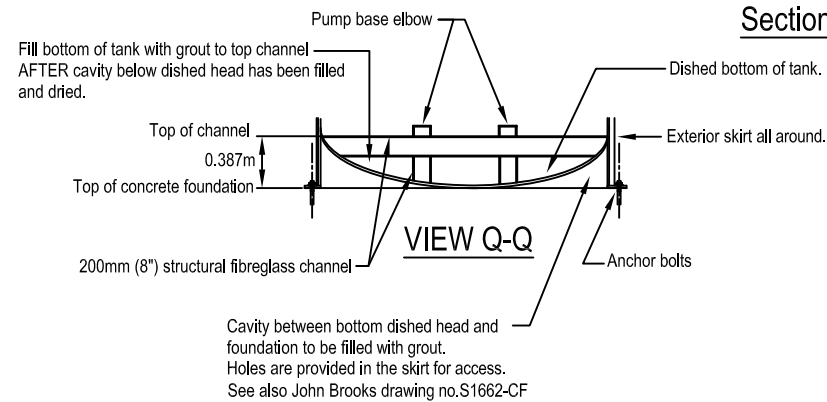

VIEW Q-Q

Cavity between bottom dished head and foundation to be filled with grout. Holes are provided in the skirt for access. See also John Brooks drawing no.S1662-CF

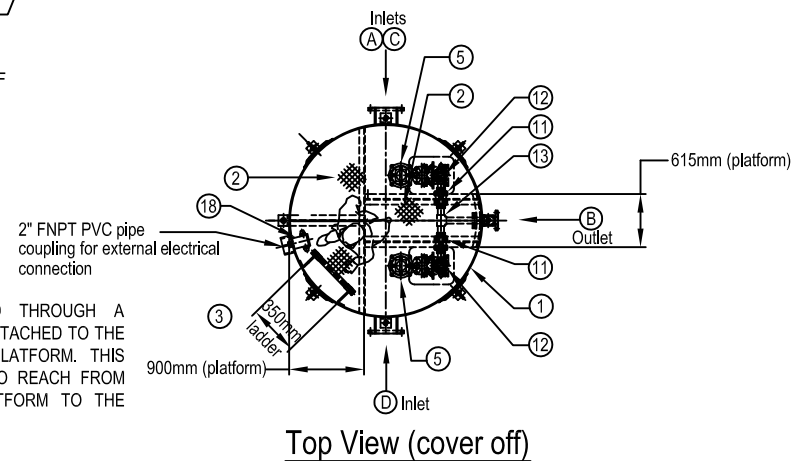

Top View (cover off)

NOTE:
FLOAT CABLES ARE ROUTED THROUGH A SECTION OF 6" PIPE WHICH IS ATTACHED TO THE SUPPORTING BEAM OF THE PLATFORM. THIS ALLOWS THE FLOAT CABLES TO REACH FROM THE UNDERSIDE OF THE PLATFORM TO THE JUNCTION BOX EASILY.

REFERENCE	CONNECTION	SIZE	TYPE	ORIENTATION	ELEVATION
(A)	200mm (8")	Flanged to match 150# F.F.	~ 270°	79.600m	
(B)	100mm (4")	Flanged to match 150# F.F.	~ 0°	81.600m	
(C)	200mm (8")	Flanged to match 150# F.F.	~ 270°	78.350m	
(D)	200mm (10")	Flanged to match 150# F.F.	~ 90°	78.300m	

Item	Qty.	Detailed Description, Dimensions, Material	Material	Weight (kg) (Lbs)
20	2	HANDLE EXTENSION	STAINLESS STEEL	
19	2	PUMP LIFTING CHAIN	GALVANIZED STEEL	
18	1	JUNCTION BOX	PLATED CAST IRON	
17	1	LIQUID LEVEL CONTROL HANGER	STAINLESS STEEL	
16	5	MECHANICAL FLOAT SWITCH	POLYSTYRENE	
15B	1	(100mm) SHORT VENT	PVC	
15A	1	(100mm) LONG VENT	PVC	
14	4	LIFTING LUGS	FIBREGLASS	
13	1	(50mm) TEE	PVC	
12	2	(50mm) 90° ELBOW	PVC	
11	2	(50mm) BALL VALVE	PVC	
10	2	(50mm) CHECK VALVE	PVC	
9	4	INTERMEDIATE RAIL SUPPORT	GALVANIZED STEEL	
8	-	(50mm) PIPING, MISC. LENGTHS	PVC	
7	2	PUMP LIFTING RAILS	GALVANIZED STEEL	
6	2	QUICK DISCONNECT COUPLING	CAST IRON	
5	2	5 HP SUBMERSIBLE GRINDER PUMP 50mm DISCHARGE	CAST IRON/BRONZE	
4	8	FOUNDATION BOLTS (HILTI) SEE DWG S1662-CF	STAINLESS STEEL	
3	1	ACCESS LADDER ASSEMBLY	ALUMINUM	
2	1	ACCESS PLATFORM	FIBREGLASS	
1	1	TANK ASSEMBLY	FIBREGLASS	

Bill Of Material

Customer: _____
Designed/Drawn By: R.J./V.B./K.F.

Title/Assembly/Part: General Arrangement Drawing for JB Submersible Station with 5HP Submersible Grinder Pumps
Date: DD/MM/YY 26/05/10
Scale: N.T.S.
Drawing Filename: _____
Location: _____

Drawing Number: S1662-GA
Rev. B



ENGINEERED PRODUCTS

Zoeller Family of Water Solutions™

MAIL TO: P.O. BOX 16347 • Louisville, KY 40256-0347
 SHIP TO: 3649 Cane Run Road • Louisville, KY 40211-1961
 (502) 778-2731 • 1 (800) 928-PUMP • FAX (502) 774-3624

Product information presented here reflects conditions at time of publication. Consult factory regarding discrepancies or inconsistencies.

visit our web site:
www.zoeller.com



Covered by US Patent Number 6,364,620.

X70 HAZARDOUS ENVIRONMENT SERIES
CLASS I, DIVISION 1, GROUPS C & D
PRODUCT FEATURES
2 HP Grinder Pumps



Certified to CSA Standard C22.2 No. 145

APPLICATIONS

- Pump stations
- Housing developments
- Pressure sewers
- Class I, Division 1 Group C & D locations
- WARNING: Not for use in acidic, methanol or ethyl acetate atmospheres.

MATERIAL FEATURES

PUMP:

- 440 stainless steel cutter and plate hardened to Rockwell C55-60
- Discharge size - 1/4" NPT
- Seals - dual mechanical carbon/rotary ceramic/stationary upper, carbon/silicon carbide lower
- Moisture detection system
- Construction - Cast iron ASTM A-48, Class 30, 30,000# tensile strength, protected with a corrosion resistant baked on epoxy powder coating
- Attaching hardware - 304 stainless steel
- O-ring seals - Viton
- Vortex Impeller - Ductile Iron (X7011), Bronze (X7012 and X7013)
- Optional:

<input type="checkbox"/> Trimmed impeller (reversing models only)	<input type="checkbox"/> X7011 Reversing model
<input type="checkbox"/> Silicon carbide seal(s)	<input type="checkbox"/> X7012 High head model
<input type="checkbox"/> 25' power and sensor cables	<input type="checkbox"/> X7013 High flow model
<input type="checkbox"/> 35' power and sensor cables	<input type="checkbox"/> Non-sparking rail system
<input type="checkbox"/> 50' power and sensor cables	<input type="checkbox"/> Bronze Impeller (7011 only)

MOTOR:

- FM and CSA rated Class I, Division 1, Group C & D construction.
- 2 HP, 3450 RPM
- 1 Phase - 200/230 Volt
- 3 Phase - 200/230/460/575 Volt
- Stator - Class F insulation and lead wires
 Nema B design
- Integral thermal overload (1 phase)
- Thermal sensor with leads (3 phase)
- Housing - Cast iron, oil-filled
- Ball bearings - Upper and lower high carbon chromium steel
- Power and sensor cable length - 20'

FEATURES

1. 20' heavy duty power cable.
2. Protected cable entrance.
3. Each conductor is individually sealed to eliminate cord wicking of liquids.
4. Stainless steel lifting bail.
5. Oil-filled explosion proof rated motor housing assures uniform heat distribution, lubricates bearings, and conducts heat for cooler running.
6. Heavy duty explosion proof rated motor features ball bearing construction. Class F motor insulation is double dipped and baked. End connections and lead wires are Class F. At maximum load, winding temperature will not exceed 250°F with motor housing not submerged.
7. Tandem seals. Carbon/rotating, ceramic/stationary upper, carbon/silicon carbide lower, Buna-N elastomers.
8. Upper and lower high carbon chromium steel ball bearings.
9. Stainless steel shaft and hardware resists corrosion.
10. Patented moisture detection system with upper and lower probes, protecting the motor from liquid entry.
11. Thermal sensor protection.
12. 20' sensor cable.
13. Vortex impeller design, fully balanced with integral pump out vane to clear debris.
14. "Star" type stainless steel cutter and plate hardened to Rockwell C55-60.
15. Concentric case reduces radial loading for longer bearing and seal life.
16. 1/4" NPT vertical discharge.
17. Vent hole helps prevent air locking.
18. Cast in support legs enabling the pump to be free standing.
19. Class 30 cast iron housing protected with corrosion resistant baked on epoxy powder coating.
20. Finned motor housing and adapter for quicker heat dissipation.

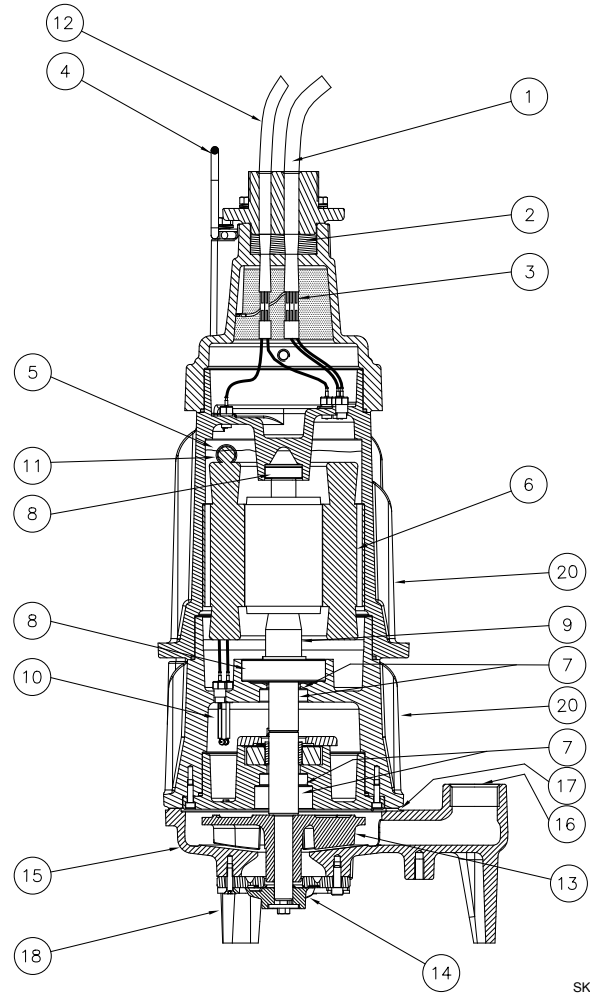

SK2824



HAZARDOUS ENVIRONMENT SERIES

CLASS I, DIVISION 1, GROUPS C & D

2 HP GRINDER PUMPS TECHNICAL DATA



MODELS:	<input type="checkbox"/> X7011	<input type="checkbox"/> X7012	<input type="checkbox"/> X7013
CONFIGURATION:	REVERSING	HIGH HEAD	HIGH FLOW
PUMP NAME PLATE HORSEPOWER:	2.0	2.0	2.0
SERVICE FACTOR:	1.2	1.2	1.2
NEC LOCKED ROTOR CODE:	K	K	K
MAXIMUM KW INPUT:	3.9	3.9	3.9
STANDARD IMPELLER DIAMETER:	5.515"	6.125"	6.188"
DISCHARGE SIZE:	1.25" NPT	1.25" NPT	1.25" NPT

IMPELLER TYPE:	VORTEX	TANDEM SEALS:	STANDARD
CUTTER & PLATE:	SS HARDENED TO 55-60 ROCKWELL	MOTOR DESIGN LETTER:	NEMA B (3 Ph) NEMA L (1Ph)
PUMP NET WEIGHT: lbs.	139 lbs.	POWER CORD LENGTH: ft (m) (20' STANDARD)	<input type="checkbox"/> 25' (7.6 m) <input type="checkbox"/> 35' (10.7 m) <input type="checkbox"/> 50' (15.2 m)
O-RINGS:	VITON		
MOTOR SHAFT:	416 SS	POWER CORD:	14 GAUGE SOW
RPM:	3450	STATOR & LEAD WIRES INSULATION:	CLASS F
MOTOR TYPE:	SUBMERSIBLE EXPLOSION PROOF*	MAXIMUM STATOR TEMPERATURE:	311°F (155°C)

SHAFT SEAL CONSTRUCTION:	STANDARD	CARBON/CERAMIC UPPER CARBON/SILICON CARBIDE LOWER
	OPTIONAL UPPER	<input type="checkbox"/> CARBON /SILICON CARBIDE <input type="checkbox"/> SILICON CARBIDE/SILICON CARBIDE
	OPTIONAL LOWER	<input type="checkbox"/> SILICON CARBIDE/SILICON CARBIDE
STANDARD SENSING DEVICES**	MOTOR THERMAL SHUTOFF	THERMAL SENSORS
	MOISTURE DETECTION	MOISTURE SENSING PROBES
IMPELLER MATERIAL	X7011	STANDARD DUCTILE IRON <input type="checkbox"/> OPTIONAL BRONZE
	X7012 & X7013	STANDARD BRONZE
IMPELLER TRIM - REVERSING MODELS ONLY:	<input type="checkbox"/> OPTIONAL	DESIGN POINT: ____ GPM @ ____' TDH, IMPELLER DIA. ____"
MAXIMUM WATER TEMPERATURE:		104°F (40°C)

* Level sensors must be Intrinsically Safe to maintain rating.

** Requires a circuit in control panel to function.

MODEL	HP	SERVICE FACTOR	<input type="checkbox"/> 200V / 1 PH		<input type="checkbox"/> 230V / 1 PH		<input type="checkbox"/> 200V / 3 PH		<input type="checkbox"/> 230V / 3 PH		<input type="checkbox"/> 460V / 3 PH		<input type="checkbox"/> 575V / 3 PH	
			FLA	LRA	FLA	LRA	FLA	LRA	FLA	LRA	FLA	LRA	FLA	LRA
X7011	2.0	1.2	20.0	60.7	17.2	57.3	12.3	47.0	10.8	41.9	5.5	20.6	4.5	16.2
X7012	2.0	1.2	20.0	60.7	17.2	57.3	12.3	47.0	10.8	41.9	5.5	20.6	4.5	16.2
X7013	2.0	1.2	20.0	60.7	17.2	57.3	12.3	47.0	10.8	41.9	5.5	20.6	4.5	16.2

RESERVE POWERED DESIGN

For unusual conditions a reserve safety factor is engineered into the design of every Zoeller® pump.

Zoeller® Engineered Products • 3649 Cane Run Road • Louisville, Kentucky 40211-1961 • (502) 778-2731

SWPA Data Categories Presented -- Data on this sheet supply design information as the minimum recommended by the Submersible Wastewater Pump Association and is defined in accordance with SWPA's Standardized Definitions for Pump and Motor Characteristics. The accuracy of the data is the responsibility of Zoeller® Engineered Products.

Your Peace of Mind is Our Top Priority™

Product information presented here reflects conditions at time of publication. Consult factory regarding discrepancies or inconsistencies.



ENGINEERED PRODUCTS

Zoeller Family of Water Solutions™

MAIL TO: P.O. BOX 16347 • Louisville, KY 40256-0347
SHIP TO: 3649 Cane Run Road • Louisville, KY 40211-1961
(502) 778-2731 • 1 (800) 928-PUMP • FAX (502) 774-3624

SECTION: Z4.30.055
ZM2620
0111
Supersedes
New

visit our web site:
www.zoeller.com



Patent No.
6,364,620

X70 HAZARDOUS ENVIRONMENT SERIES PERFORMANCE DATA CLASS I, DIVISION 1, GROUPS C & D 2 HP Grinder Pump

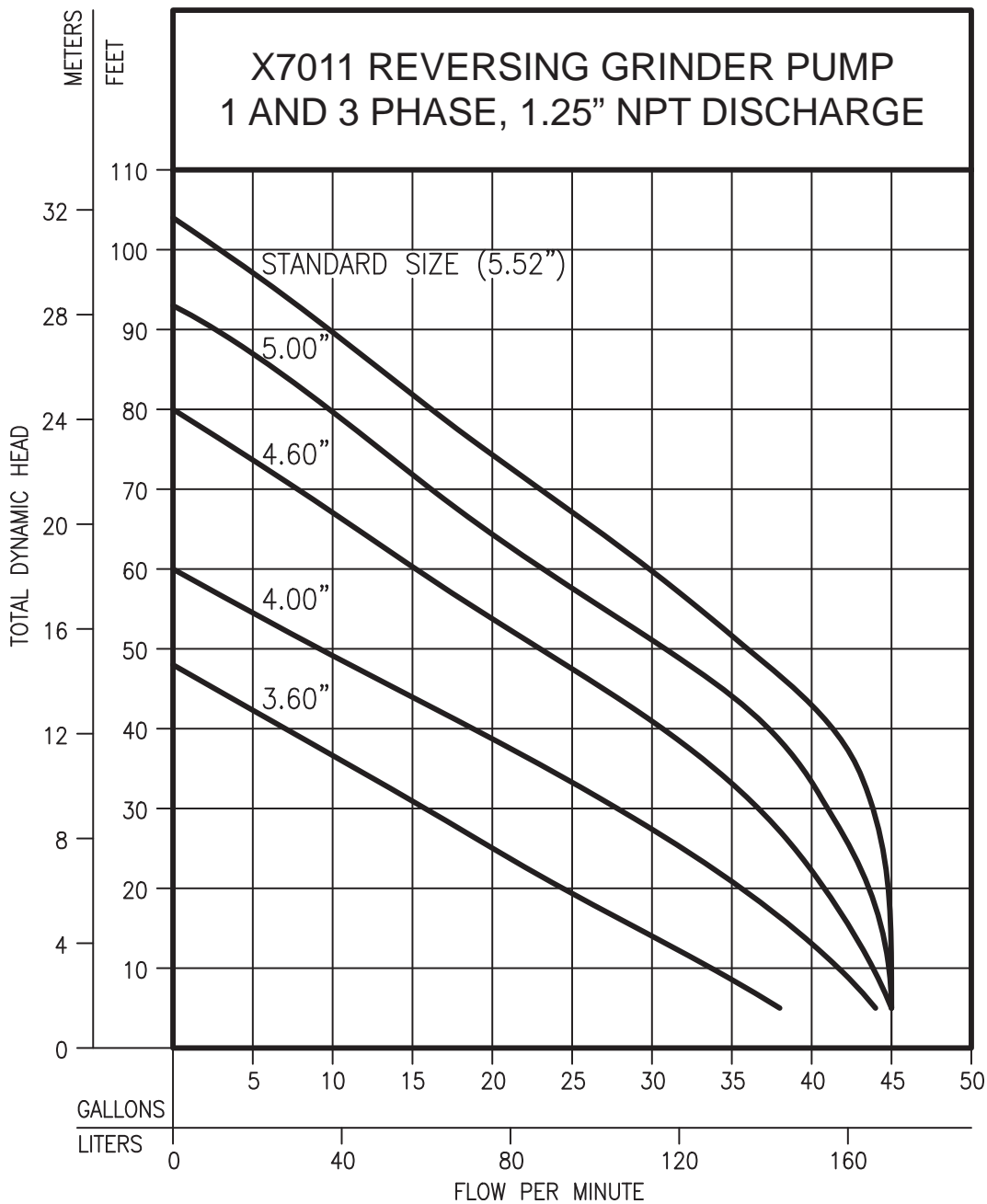



X70 HAZARDOUS ENVIRONMENT SERIES

PERFORMANCE DATA

CLASS I, DIVISION 1, GROUPS C & D

2 HP Grinder Pump



Certified to CSA Standard C22.2 No. 145

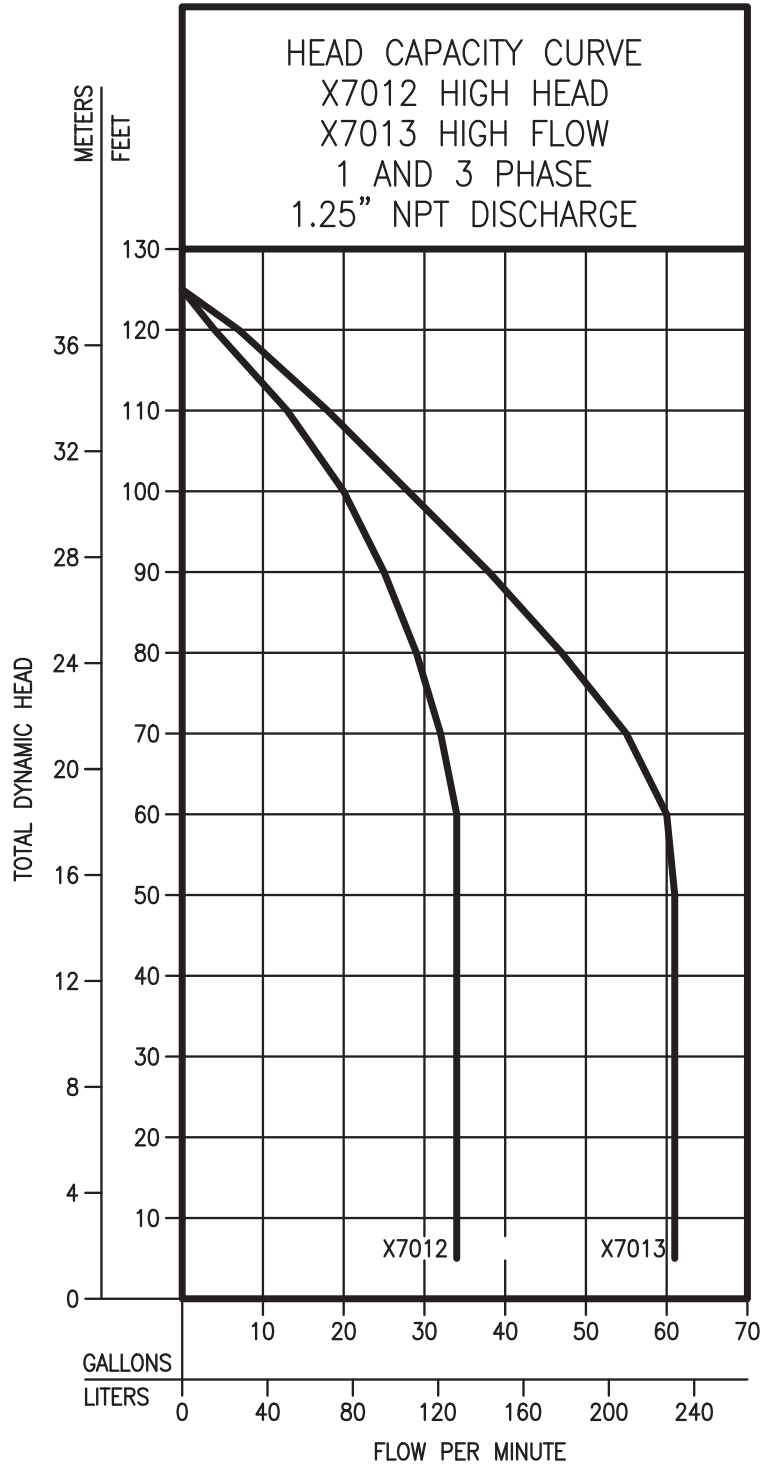

016532

Zoeller Engineered Products • 3649 Cane Run Road • Louisville, Kentucky 40211-1961 • (502) 778-2731

SWPA Data Categories Presented -- Data on this sheet supply design information as the minimum recommended by the Submersible Wastewater Pump Association and is defined in accordance with SWPA's Standardized Definitions for Pump and Motor Characteristics. The accuracy of the data is the responsibility of Zoeller Engineered Products.

© Copyright 2011 Zoeller Co. All rights reserved.



October 11, 2018
MTE File No.: C43022-100

Andrea Betty MCIP RPP
Director of Planning and Community Development
Town of Penetanguishene
10 Robert Street West, P.O Box 5009
Penetanguishene, ON L9M 2G2

abetty@penetanguishene.ca

Dear Andrea Betty:

**Re: Record of Site Condition
166, 176 and 200 Fox Street, Penetanguishene, Ontario**

MTE Consultants Inc. (MTE) has been retained by Maple Leaf Marinas to complete Record of Site Condition (RSC) filing for Bay Moorings Marina located at 166, 176 and 200 Fox Street in Penetanguishene, Ontario (the "Site"). At the request of Maple Leaf Marinas, we have prepared the following general overview of the RSC requirements and process for the Site.

The Site operated as a marina until the end of the 2017 boating season, which is considered a commercial/industrial land use under Ontario Regulation 153/04 (as amended). It is our understanding that residential redevelopment is planned for the Site. As such, the Ministry of the Environment, Conservation and Parks (MECP) will require RSC filing in advance of redevelopment, since residential is considered a more sensitive land use than commercial/industrial under Ontario Regulation 153/04 (as amended).

RSC filing will be completed following the process prescribed by the MECP. MTE is currently undertaking a Phase One Environmental Site Assessment (ESA) and a Phase Two ESA in accordance with Ontario Regulation 153/04 (as amended) to support eventual RSC filing. The results of these investigations will be subject to a technical and administrative review by the MECP at the time of RSC filing.

Please do not hesitate to contact the undersigned if you require any further information related to the above.

Yours truly,

MTE CONSULTANTS INC.

Sean Anderson, P.Eng., QP_{ESA}
Environmental Engineer

SCA

M:\43022\100\Record of Site Condition\Bay Moorings RSC Letter to Town.doc

APPENDIX E

**TRAFFIC IMPACT ASSESSMENT
CALCULATIONS**

- A - Minimum Stopping Sight Distance, Table E3-1.
- A₁ - Distance travelled in 3 s, Table E3-2.
- B - Safe Sight Distance for P vehicle, crossing 2-lane highway from stop.
- C - Safe Sight Distance for P vehicle, turning left into 2-lane highway across P vehicle approaching from left.
- D - Safe Sight Distance for P vehicle to turn left into 2-lane highway and attain assumed operating speed before being overtaken by P vehicle approaching in same direction at design speed.
- E - Safe Sight Distance for P vehicle to turn right into 2-lane highway and attain assumed operating speed before being overtaken by P vehicle approaching in same direction at design speed.

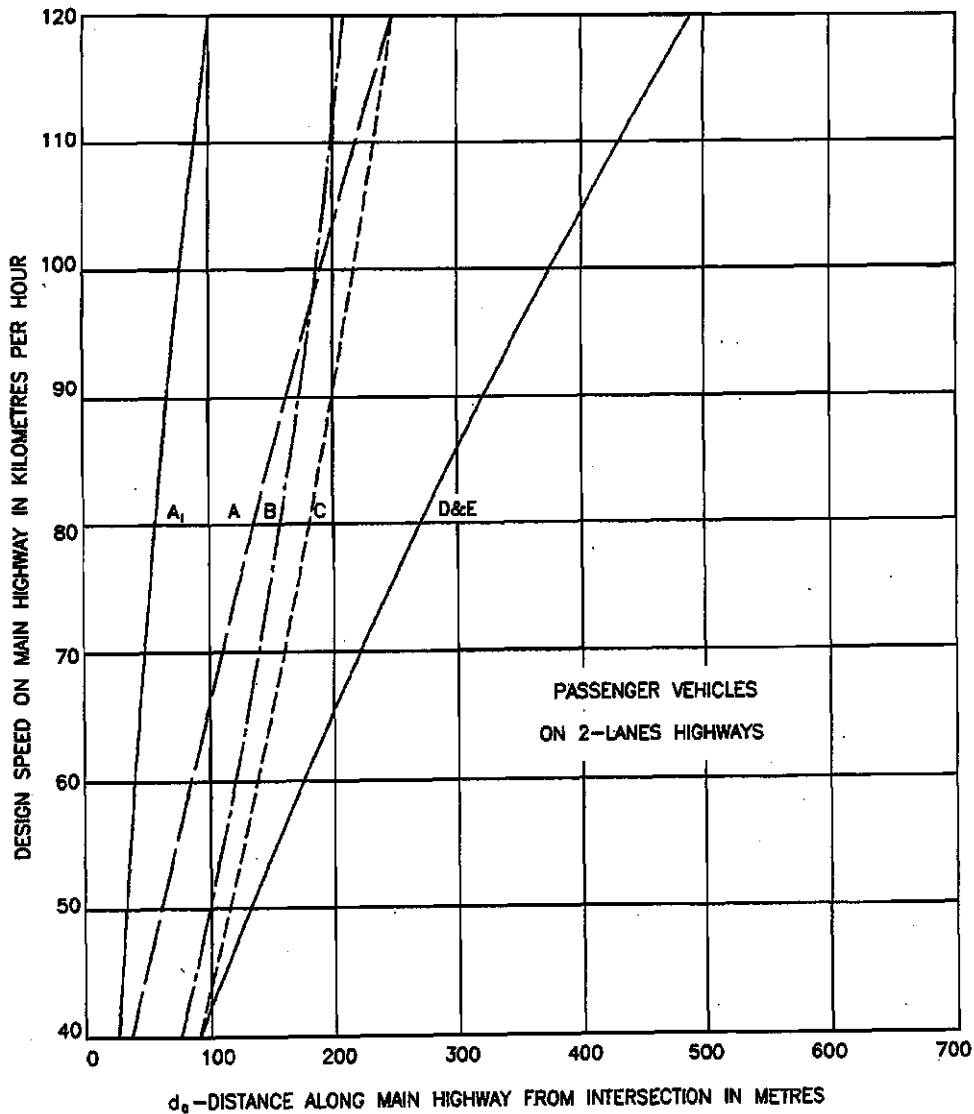

Figure E3-6

Sight Distance Requirements for Stopping
Crossing and Turning Movements

Senior Adult Housing - Detached (251)

Vehicle Trip Ends vs: Dwelling Units
On a: Weekday,
Peak Hour of Adjacent Street Traffic,
One Hour Between 7 and 9 a.m.

Setting/Location: General Urban/Suburban
 Number of Studies: 29
 Avg. Num. of Dwelling Units: 583
 Directional Distribution: 33% entering, 67% exiting

Vehicle Trip Generation per Dwelling Unit

Average Rate	Range of Rates	Standard Deviation
0.24	0.13 - 0.84	0.10

*Average of Rates \rightarrow page 339-342 and 344 : $\frac{0.24 + 0.30 + 0.34 + 0.39 + 0.23}{5} = \underline{\underline{0.30}}$

Data Plot and Equation

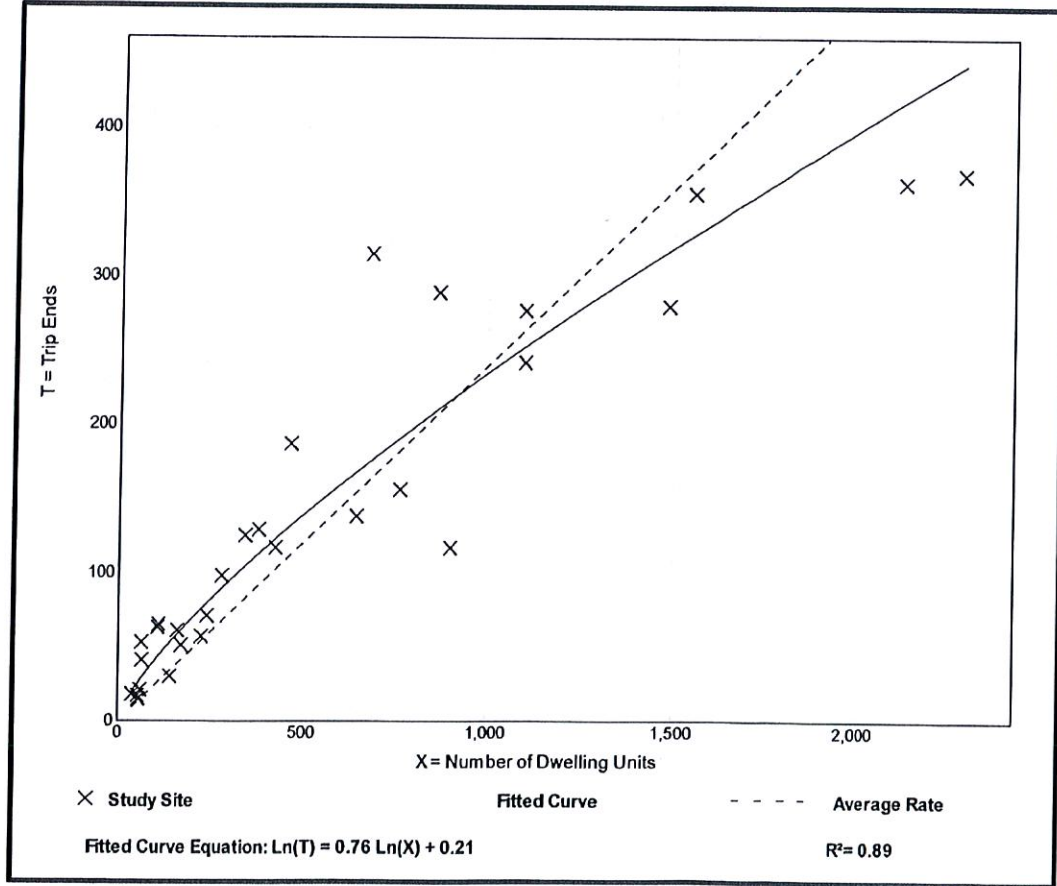

Senior Adult Housing - Detached (251)

Vehicle Trip Ends vs: Dwelling Units
On a: Weekday,
Peak Hour of Adjacent Street Traffic,
One Hour Between 4 and 6 p.m.
Setting/Location: General Urban/Suburban
 Number of Studies: 30
 Avg. Num. of Dwelling Units: 582
 Directional Distribution: 61% entering, 39% exiting

Vehicle Trip Generation per Dwelling Unit

Average Rate	Range of Rates	Standard Deviation
0.30	0.17 - 0.95	0.13

Data Plot and Equation

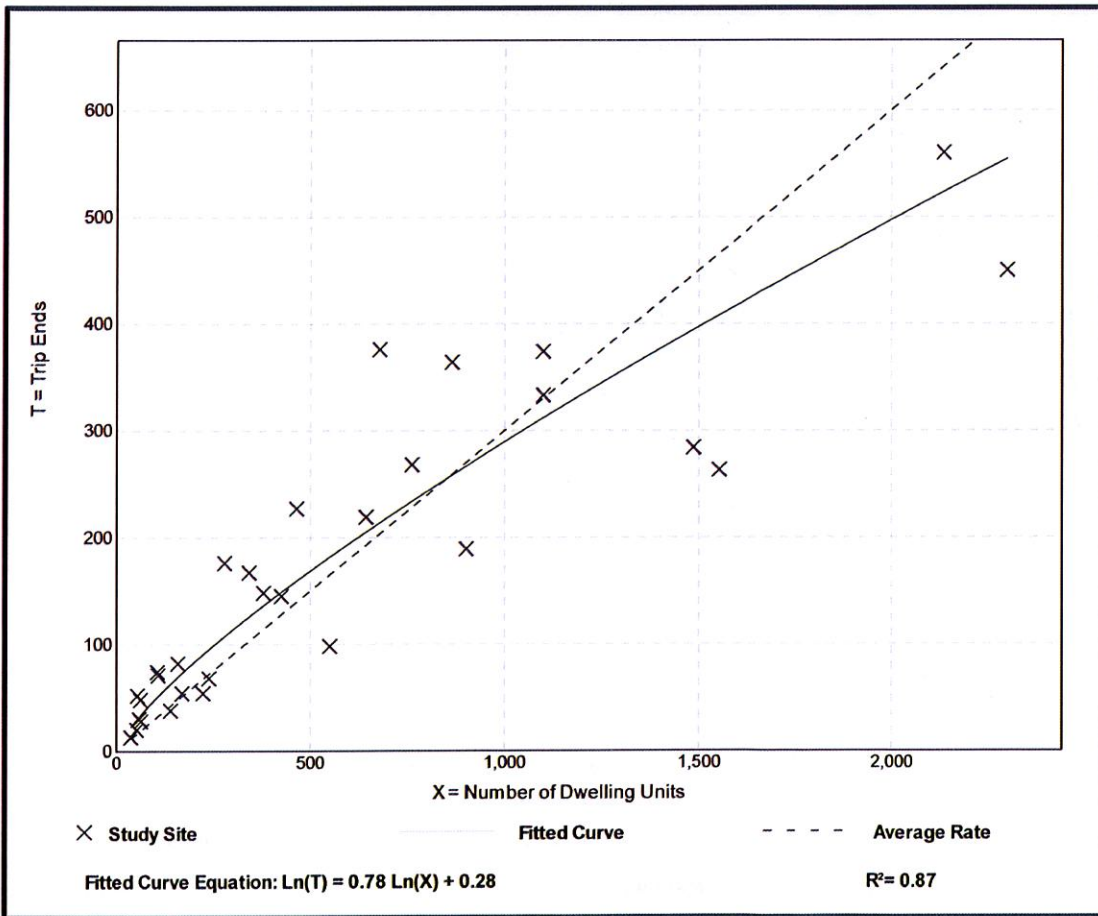

Senior Adult Housing - Detached (251)

Vehicle Trip Ends vs: Dwelling Units
On a: Weekday,
AM Peak Hour of Generator

Setting/Location: General Urban/Suburban
 Number of Studies: 22
 Avg. Num. of Dwelling Units: 444
 Directional Distribution: 42% entering, 58% exiting

Vehicle Trip Generation per Dwelling Unit

Average Rate	Range of Rates	Standard Deviation
0.34	0.21 - 0.90	0.14

Data Plot and Equation

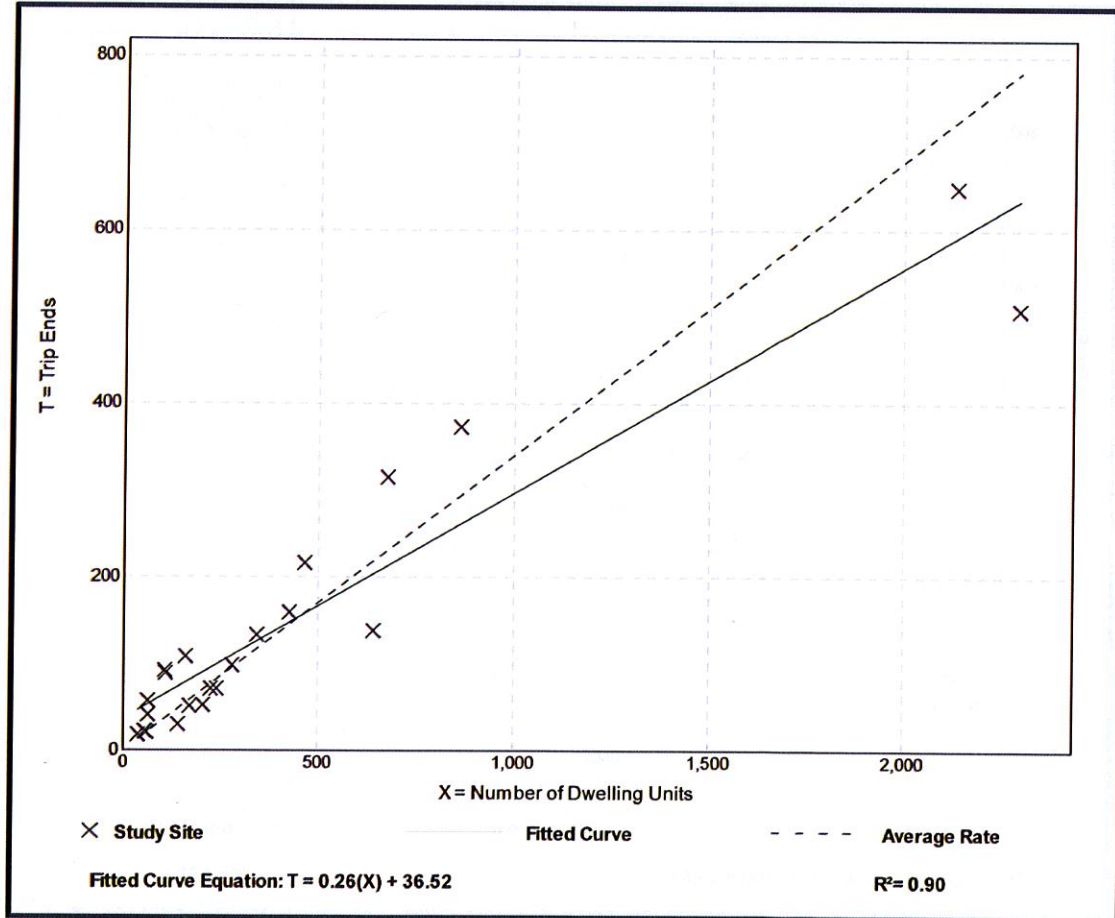

Senior Adult Housing - Detached (251)

Vehicle Trip Ends vs: Dwelling Units
On a: Weekday,
PM Peak Hour of Generator

Setting/Location: General Urban/Suburban
 Number of Studies: 22
 Avg. Num. of Dwelling Units: 444
 Directional Distribution: 57% entering, 43% exiting

Vehicle Trip Generation per Dwelling Unit

Average Rate	Range of Rates	Standard Deviation
0.39	0.20 - 1.01	0.17

Data Plot and Equation

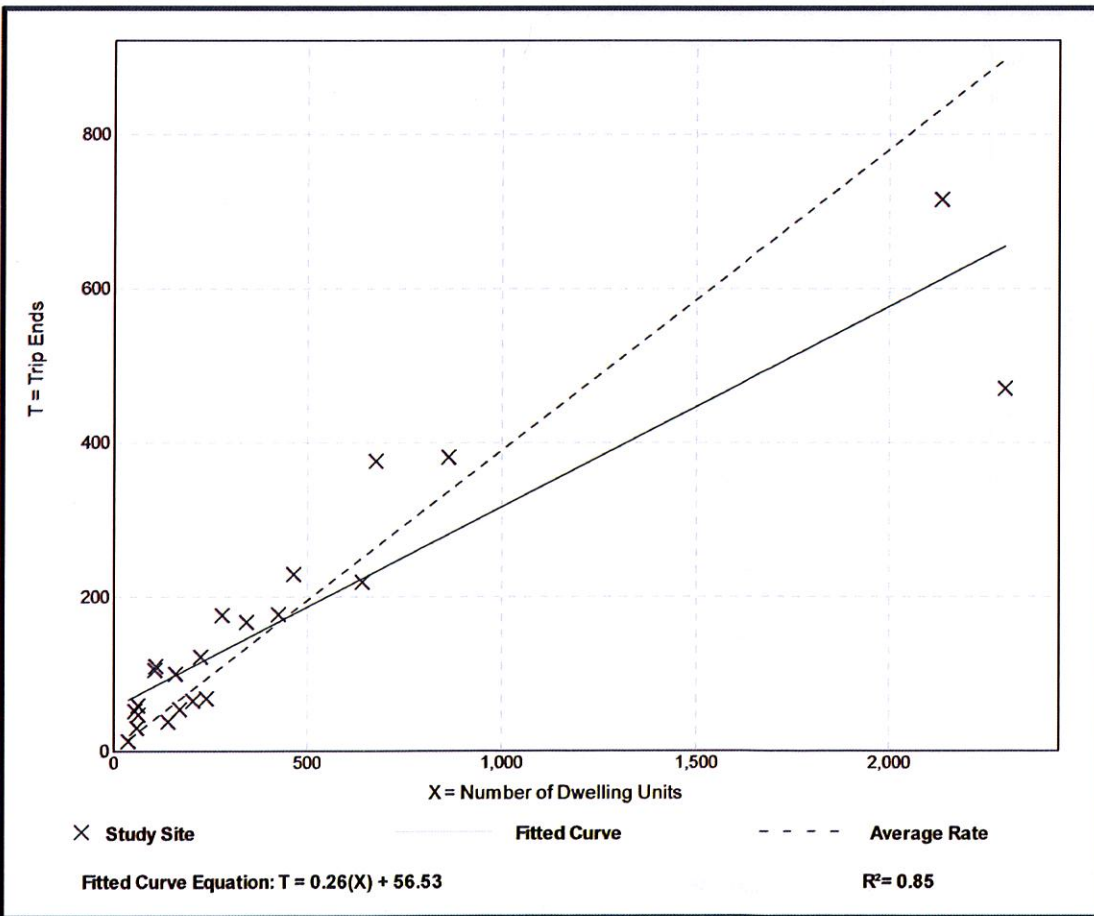

Senior Adult Housing - Detached (251)

Vehicle Trip Ends vs: Dwelling Units
On a: Saturday, Peak Hour of Generator

Setting/Location: General Urban/Suburban
 Number of Studies: 3
 Avg. Num. of Dwelling Units: 1547
 Directional Distribution: 48% entering, 52% exiting

Vehicle Trip Generation per Dwelling Unit

Average Rate	Range of Rates	Standard Deviation
0.23	0.19 - 0.27	0.29

Data Plot and Equation

Caution – Small Sample Size

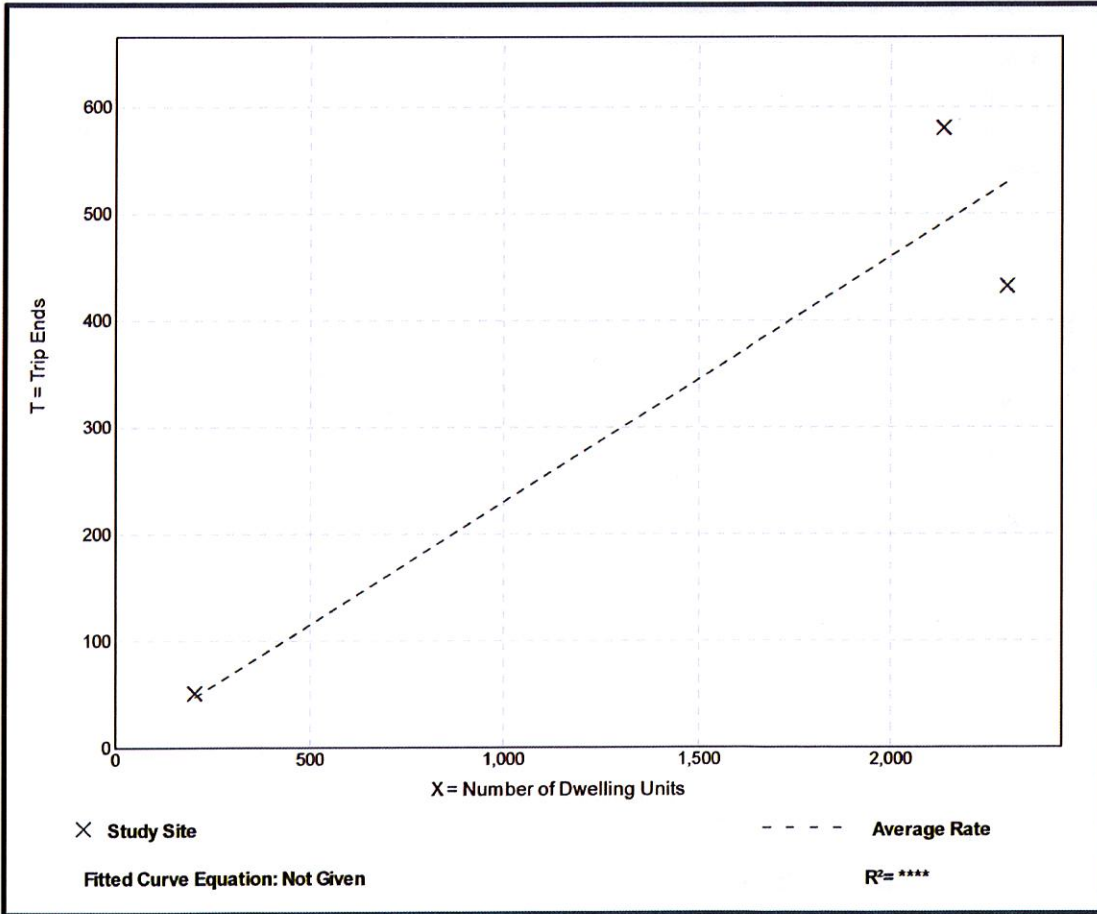

Marina (420)

Vehicle Trip Ends vs: Berths
On a: Weekday,
Peak Hour of Adjacent Street Traffic,
One Hour Between 4 and 6 p.m.
Setting/Location: General Urban/Suburban
 Number of Studies: 1
 Avg. Num. of Berths: 300
 Directional Distribution: 60% entering, 40% exiting

Vehicle Trip Generation per Berth

Average Rate	Range of Rates	Standard Deviation
0.21	0.21 - 0.21	*

*Average of Rates → page 36, 38, 40, 42 : $\frac{0.21 + 0.20 + 0.22 + 0.31}{4} = 0.235$ → use 0.25 to be conservative

Data Plot and Equation

Caution – Small Sample Size

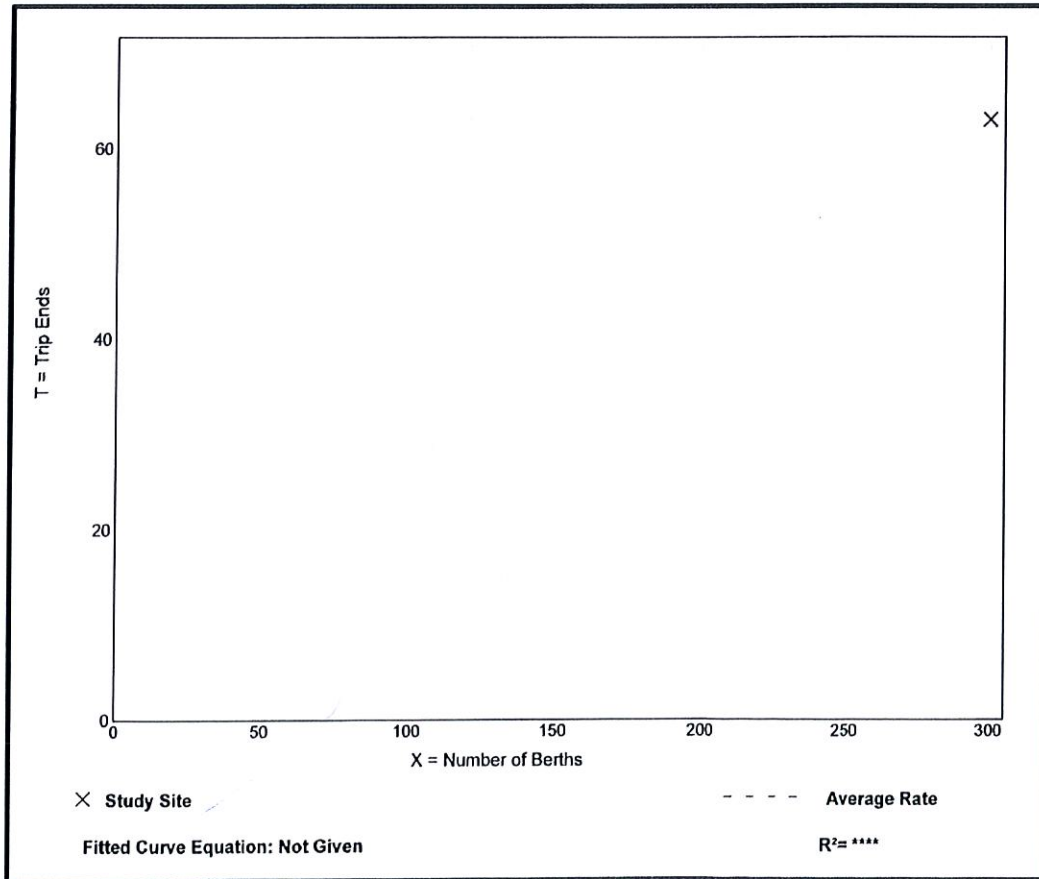

Marina (420)

Vehicle Trip Ends vs: Berths
On a: Weekday,
PM Peak Hour of Generator

Setting/Location: General Urban/Suburban
 Number of Studies: 2
 Avg. Num. of Berths: 1027
 Directional Distribution: 51% entering, 49% exiting

Vehicle Trip Generation per Berth

Average Rate	Range of Rates	Standard Deviation
0.20	0.18 - 0.29	*

Data Plot and Equation

Caution – Small Sample Size

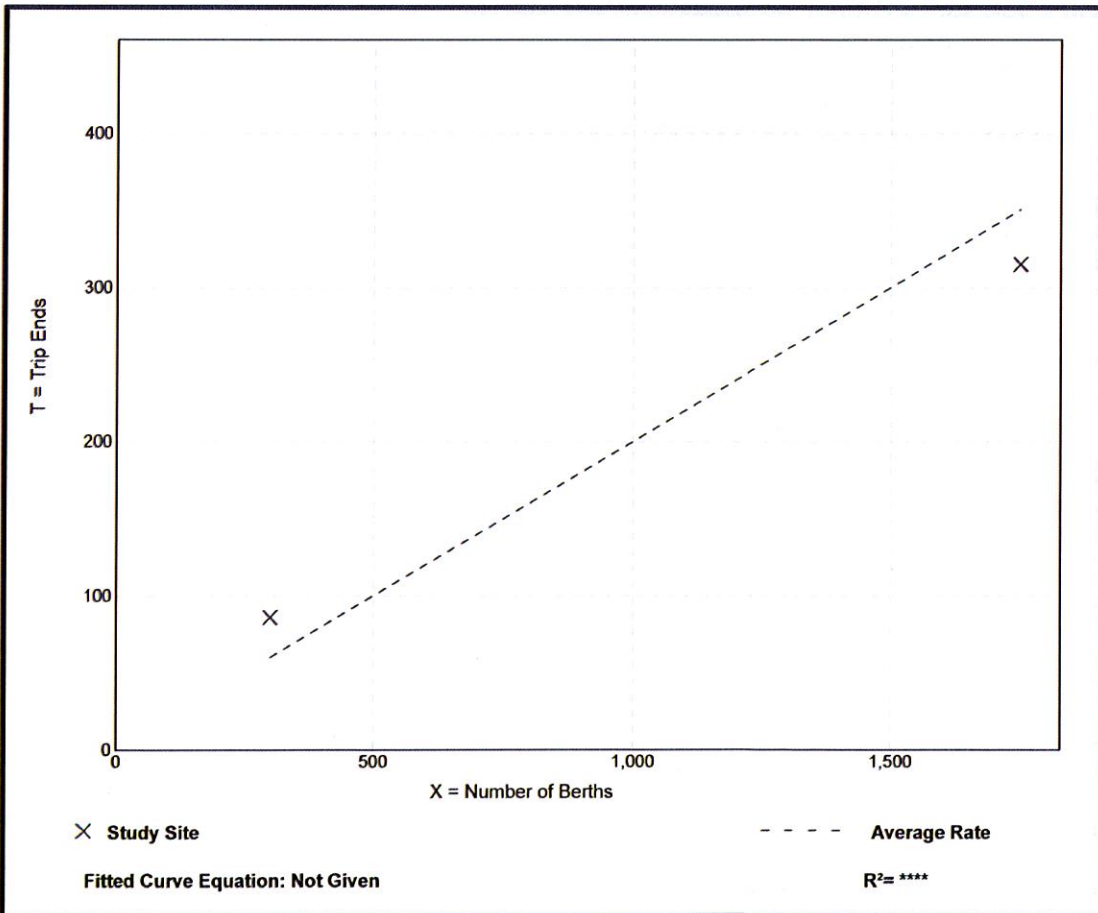

Marina (420)

Vehicle Trip Ends vs: Berths
On a: Saturday, Peak Hour of Generator

Setting/Location: General Urban/Suburban
 Number of Studies: 2
 Avg. Num. of Berths: 1027
 Directional Distribution: 44% entering, 56% exiting

Vehicle Trip Generation per Berth

Average Rate	Range of Rates	Standard Deviation
0.22	0.21 - 0.29	*

Data Plot and Equation

Caution – Small Sample Size

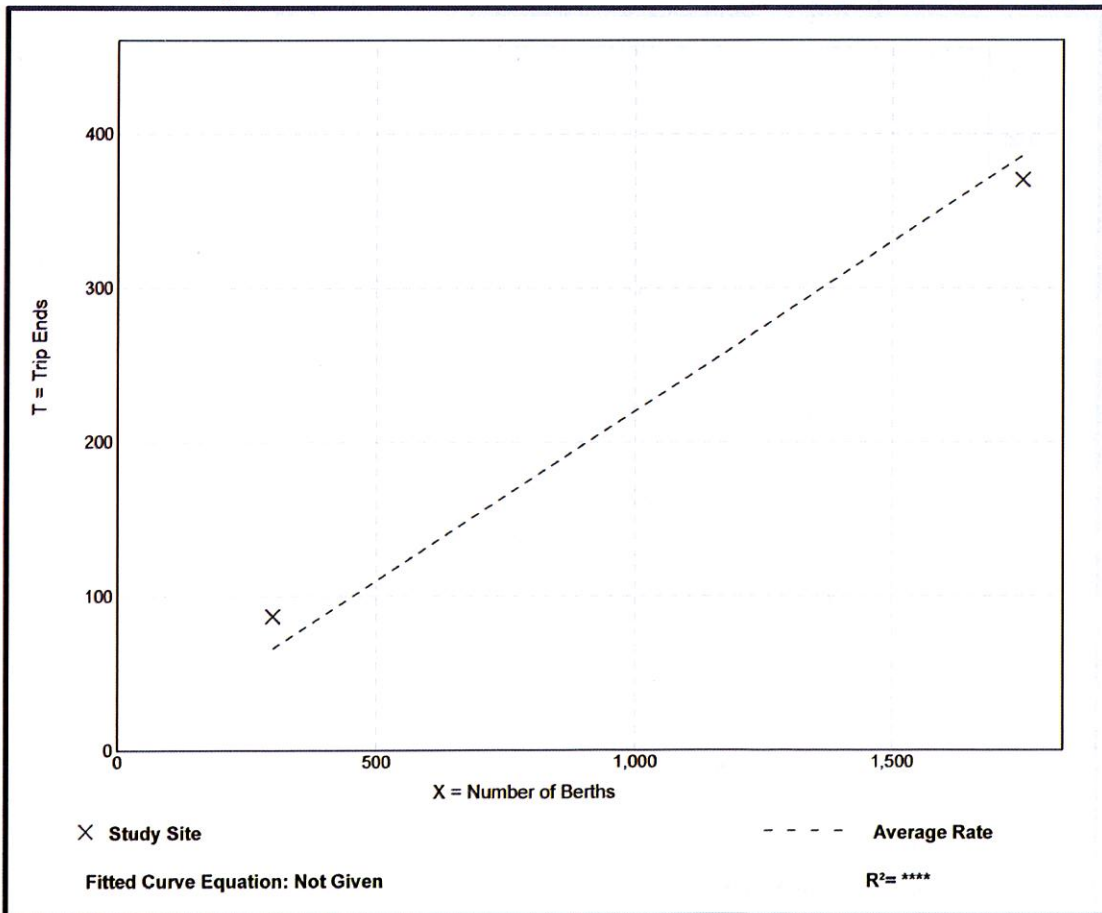

Marina (420)

Vehicle Trip Ends vs: Berths
On a: Sunday, Peak Hour of Generator

Setting/Location: General Urban/Suburban
 Number of Studies: 1
 Avg. Num. of Berths: 300
 Directional Distribution: 68% entering, 32% exiting

Vehicle Trip Generation per Berth

Average Rate	Range of Rates	Standard Deviation
0.31	0.31 - 0.31	*

Data Plot and Equation

Caution – Small Sample Size

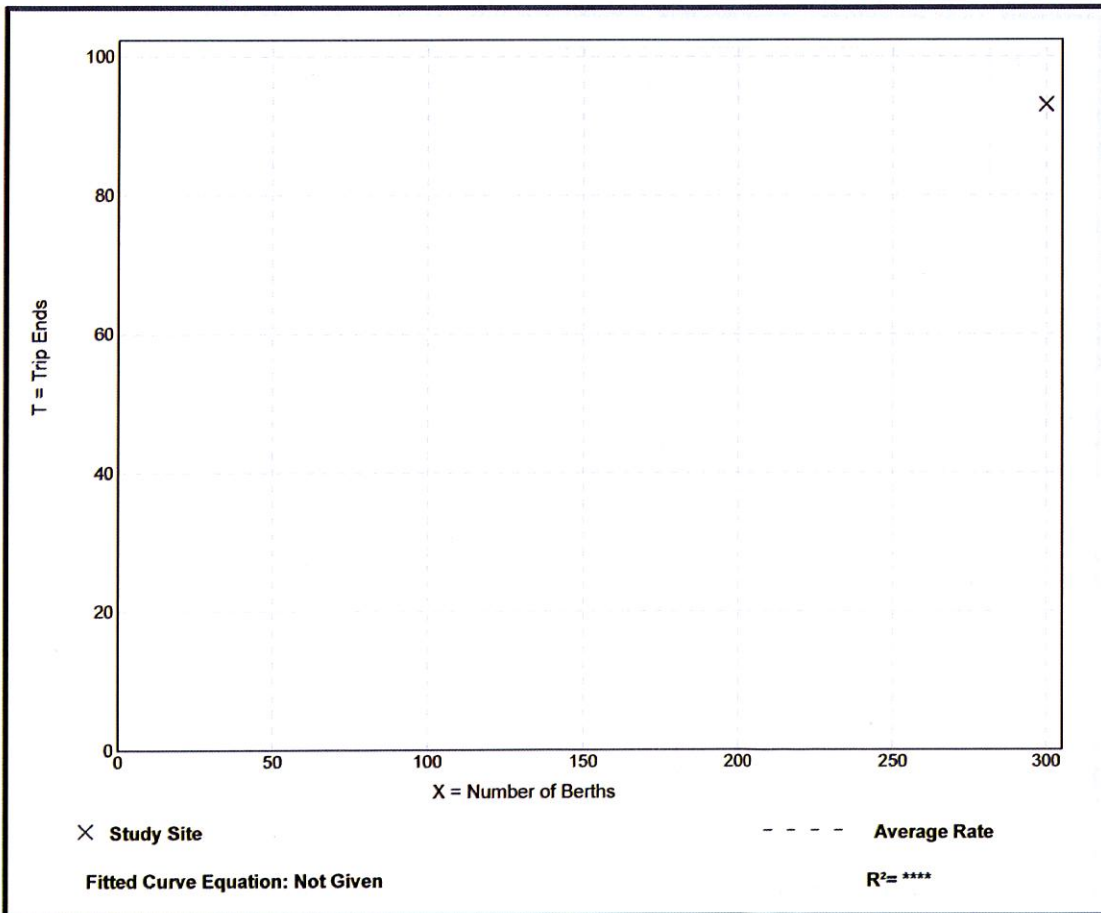

APPENDIX F

**RECORD DRAWINGS
TOWN OF PENETANGUISENE**

SEE DNG. 580-17

FOX STREET

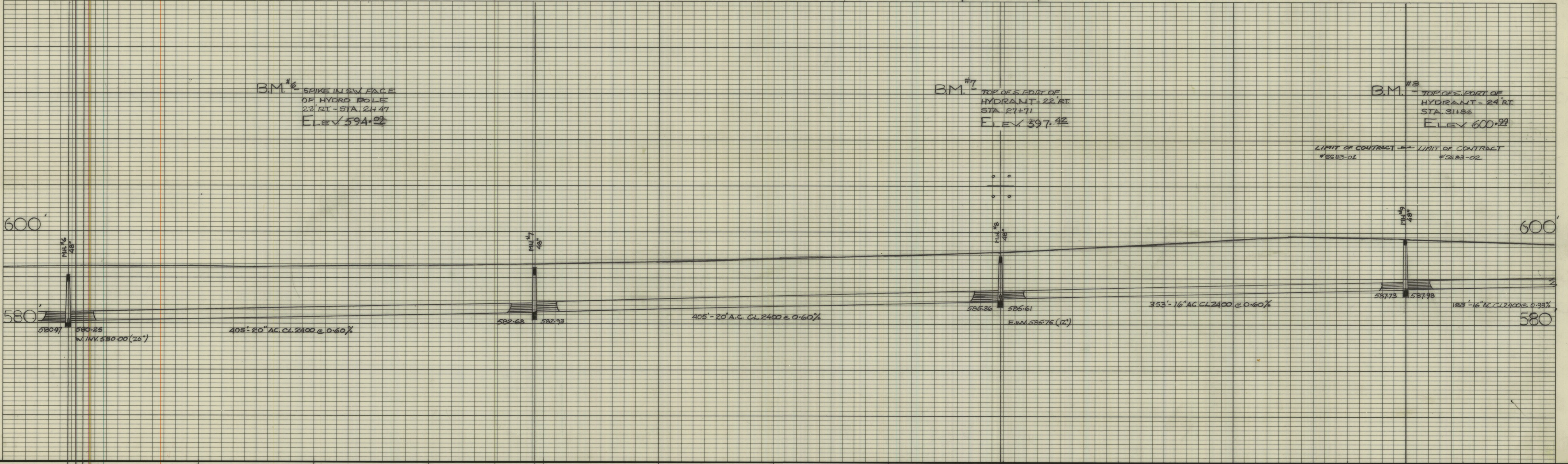
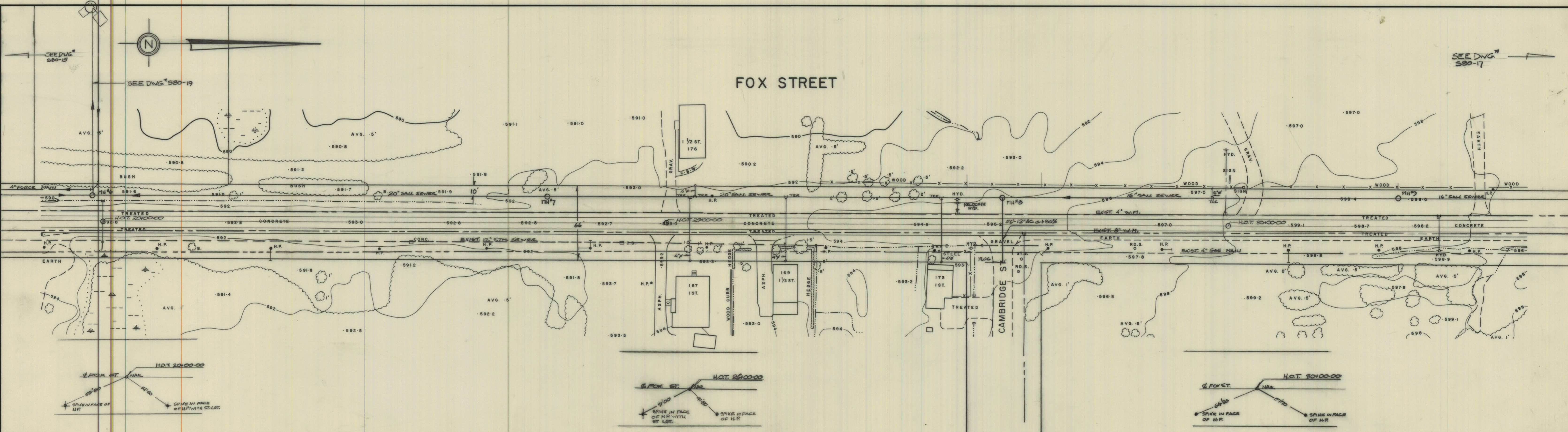

B.M. #6
SPIKE IN SW FACE
OF HYDRO POLE
23' RT. - STA. 214.47
ELEV. 594.02

B.M. #7
TOP OF S. PORT OF
HYDRANT - 22' RT.
STA. 214.71
ELEV. 597.42

B.M. #8
TOP OF S. PORT OF
HYDRANT - 24' RT.
STA. 314.86
ELEV. 600.99

LIMIT OF CONTRACT -> LIMIT OF CONTRACT
#5883-02 #5883-02

580+00	580+05	580+10	580+15	580+20	580+25	580+30	580+35	580+40	580+45	580+50	580+55	580+60	580+65	580+70	580+75	580+80	580+85	580+90	580+95	580+00
--------	--------	--------	--------	--------	--------	--------	--------	--------	--------	--------	--------	--------	--------	--------	--------	--------	--------	--------	--------	--------

Town of Penetanguishene
Public Works Department

Dsn. P.W.L. Dwg. P.W.L. Ckd. P.H.S.
Scale: Hor. 1" = 40' Ver. 1" = 10'
Date: Dec. '80 Drawing No. 580-16 M.H. #6 TO M.H. #9

No.	Revision	Date	Initial

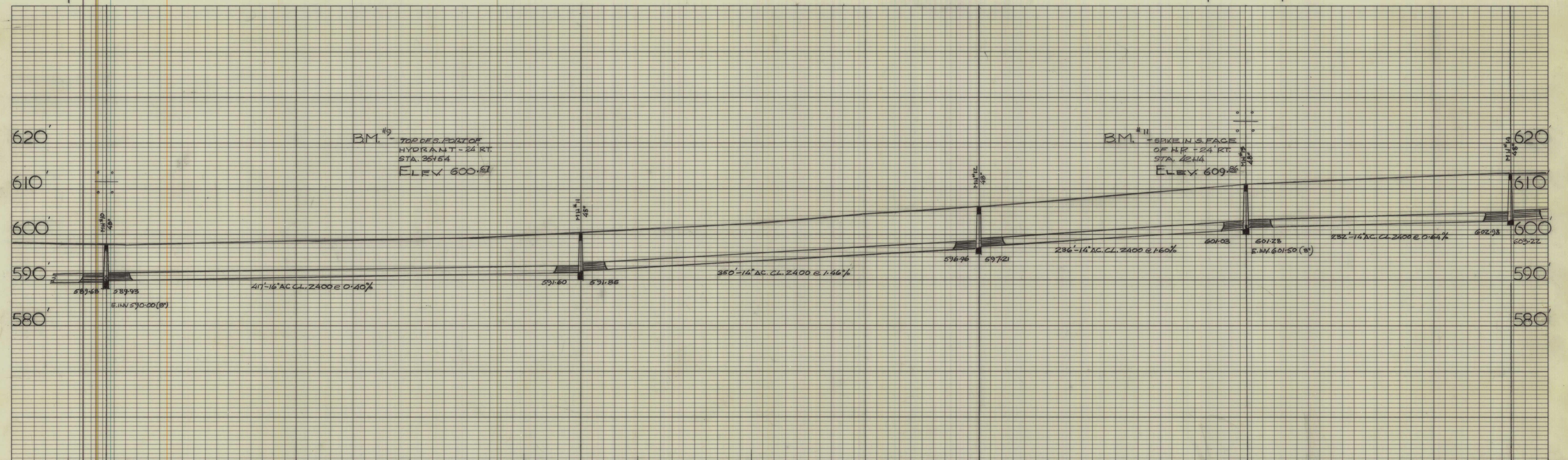
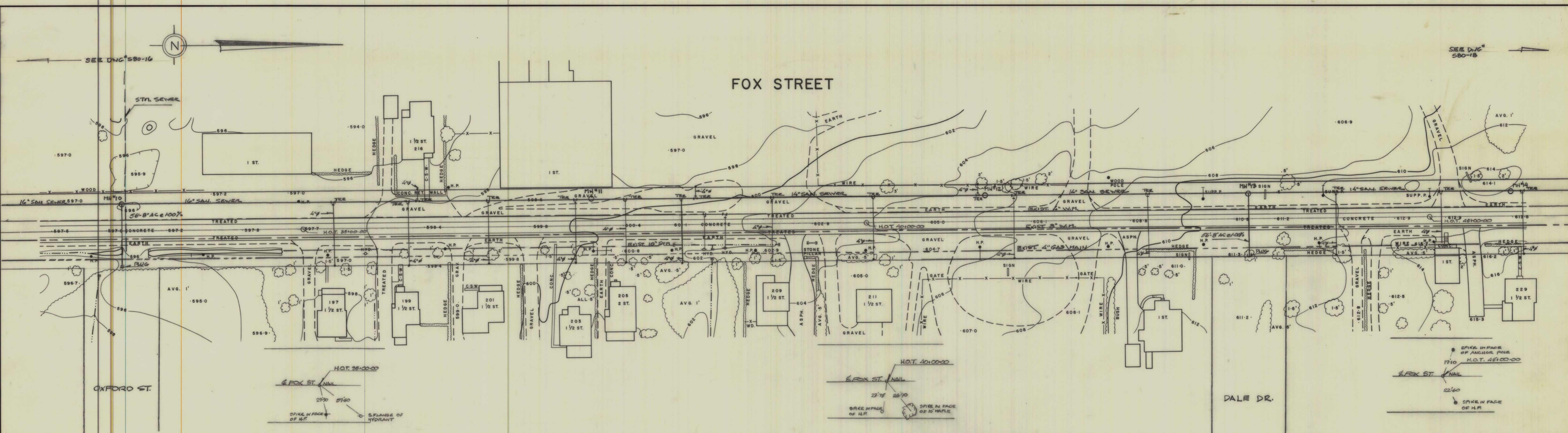

3300	3325	3350	3375	3400	3425	3450	3475	3500	3525	3550	3575	3600	3625	3650	3675	3700	3725	3750	3775	3800	3825	3850	3875	3900	3925	3950	3975	4000	4025	4050	4075	4100	4125	4150	4175	4200	4225	4250	4275	4300	4325	4350	4375	4400	4425	4450	4475	4500	4525	4550	4575	4600
------	------	------	------	------	------	------	------	------	------	------	------	------	------	------	------	------	------	------	------	------	------	------	------	------	------	------	------	------	------	------	------	------	------	------	------	------	------	------	------	------	------	------	------	------	------	------	------	------	------	------	------	------

				Town of Penetanguishene Public Works Department	
				FOX ST. SAN. SEWER YEO ST. TO BROAD ST.	
Dsn. P.W.D.	Dwg. P.W.D.	Ckd. P.W.D.	Pls	Scale	Date
Scale: 1" = 40' Ver. 1" = 10'			Date: Dec '80		
Drawing No. 580-17			MH#10 TO MH#14		
No.	Revision	Date	Initial		